

# Tooling Equipment & Accessories



MiniKrimp™

Karrykrimp

Karrykrimp 2

Parkrimp2

Pumps

Accessories



# Table of Contents

## Crimpers

Karrykrimp .....	F-10
Karrykrimp 2 .....	F-11
MiniKrimp™ .....	F-5
Parkrimp 2 .....	F-12

## Pumps

Air Over Hydraulic Pumps .....	F-13
Electric Pumps .....	F-14
Hand Pumps.....	F-13 : F-14

## Conversion Kits

Hydraulic Press, Gates, Weatherhead.....	F-16
--	------

## Sewer Hose Swager & Swage Tooling

SQ-101-SW Swager/Mender .....	F-13
-------------------------------	------

## Accessories

Cut-off Tools .....	F-17
Dies (Parkrimp 2) .....	F-15
Die Racks .....	F-15
Hose Guards/Sleeves.....	F-18 : F-23
Vise Blocks.....	F-14
Hose Insertion Depth Blocks.....	F-14





## Technical

MiniKrimp Assembly Detail .....	F-8 : F-9
Spring/Armor/PVC Guard Selection Tables.....	F-18 : F-19











# Tooling, Equipment & Accessories Visual Index

<b>MiniKrimp™</b>	94C-001-PFD	94C-002-PFD	Hose Stand 94C-MKS
	 F-5	 F-5	 F-7

<b>Karrykrimp</b>	Karrykrimp 82C-061L-PFD	Karrykrimp Bench Mount 82C-KKB-PFD	Karrykrimp2 85C-061L-PFD	Karrykrimp 2 Bench Mount 85C-KKB-PFD
	 F-10	 F-10	 F-11	 F-11

<b>Parkrimp 2</b>	Parkrimp 2 83C-081-PFD
	 F-12

<b>Swagers, Swager Tooling</b>	Swager Mender SQ-101-SW
	 F-13

<b>Pumps</b>	Hand Pump 015301	Hand Pump 82C-0HP-PFD	Hand Pump 85C-0HP-PFD	Air/Hydraulic Pump 025399	Air/Hydraulic Pump 82C-0AP
	 F-13	 F-14	 F-14	 F-13	 F-13
	Electric Pump 82C-0EP-PFD	Electric Pump 85C-0EP-PFD			
	 F-14	 F-14			



<b>Parkrimp Dies</b>	Dies	Die Storage Racks
	 F-15	 F-15



For detailed ordering information, please consult price list or contact Parflex® Division.







A Hose  
 B Tubing  
 C Coiled Air Hose & Fittings  
 D Transportation  
 E Fittings  
 F Tooling, Equipment & Accessories  
 G General Technical

# Tooling, Equipment & Accessories Visual Index

<b>Conversion Kits</b>	<b>Hydraulic Press Kit</b>	<b>Weatherhead Kit</b>	<b>Gates Kit</b>
	 F-16	 F-16	 F-16

<b>Vise Blocks</b>	<b>Vise Blocks VBS &amp; VBL</b>	<b>Hose Insertion Depth Blocks</b>	<b>TH-9-1-xxx TH-8-1-xxx</b>
	 F-14		 F-14

<b>Cutoff Tools</b>	<b>Hose Cutoff Machine 332T-115V</b>	<b>Push-Lok Cut-Off 885140</b>	<b>Hose Cutter HTC</b>	<b>Hose Cutter TH11-1</b>	<b>Plastic Tube Cutter PTC</b>
	 F-17	 F-17	 F-17	 F-17	 F-17

<b>Hose Guards &amp; Sleeves</b>	<b>AG Flat Steel Armor</b>	<b>AS Partek Sleeve</b>	<b>CNG CNGG Guard Kit</b>	<b>FS Fire Sleeve</b>	<b>HBR Bend Restrictor</b>
	 F-19	 F-20*	 F-18	 F-20*	 F-18
	<b>MG External Anti-Kink Casing</b>	<b>PSG and SSG Pre-Made Spring</b>	<b>PSG Parker Spiral Guard</b>	<b>PV Clear Vinyl</b>	<b>SG Steel Spring Guard</b>
	 F-20*	 F-19	 F-23	 F-18	 F-19
	<b>2613 Internal Flat Spring</b>	<b>2625 External Round Spring</b>	<b>2740 External Flat Spring</b>	<b>2799 Internal Round Spring</b>	
	 F-20*	 F-20*	 F-20*	 F-20*	

\* Items on page F-20 are for PTFE hose.



# Crimping Machines

## MiniKrimp™ Hand Pump Model Part No. 94C-001-PFD

The Parker Hannifin MiniKrimp is the best portable crimper on the market. By utilizing a one-piece, high-strength cast aluminum frame, the MiniKrimp is light, robust and highly corrosion resistant.

For use with 54, 55, 56, 57, 58, 91, 91N, 92, 93N, CY, MS, SF and HY Series fittings



### Features

- Lightweight, portable, compact all-in-one unit
- Unit with pump weighs only 42 pounds
- 10,000 psi and 30+ tons of force
- No gauges to set - exclusive Parkalign™ feature positions the fitting correctly every time
- Removable pusher design for easy die change
- Hand pump easily removed for use with jumper hose for bench-mounted units (Part No.- 015309)
- No additional power source required for operation
- Capable of crimping a majority of thermoplastic, rubber, PTFE and specialty hoses up to 3/4" I.D.

### Specifications

- Dimensions: 6" Deep, 13" Wide, 15" High
- Weight: 42 lbs with hand pump
- Rating: 30 tons force @ 10,000 psi maximum
- Full Cycle Time: Approximately 30 seconds

### Standard Equipment

Part Number		Description	Individual
94C-001-PFD	94C-002-PFD		Part Number
●	●	Base unit	94C-080-PFD
●		Hand pump	015301
	●	Air over hydraulic pump kit with tubing and adapters	025399
●	●	Silver die ring	82C-R01-PFD

## MiniKrimp™ Air Over Hydraulic Model Part No. 94C-002-PFD

The Parker Hannifin MiniKrimp is the best portable crimper on the market. By utilizing a one-piece, high-strength cast aluminum frame, the MiniKrimp is light, robust and highly corrosion resistant.

For use with 54, 55, 56, 57, 58, 91, 91N, 92, 93N, CY, MS, SF and HY Series fittings



### Features

- Lightweight, portable, compact all-in-one unit
- Unit with pump weighs only 45 pounds
- 10,000 psi and 30+ tons of force
- No gauges to set - exclusive Parkalign™ feature positions the fitting correctly every time
- Removable pusher design for easy die change
- Air pump utilizes a rugged activation and release lever for greater durability
- Can operate with as little as 60 psi air pressure (60-100 psi, 9 CFM recommended)
- Capable of crimping a majority of thermoplastic, rubber, PTFE and specialty hoses up to 3/4" I.D.

### Specifications

- Dimensions: 6" Deep, 12" Wide, 15" High
- Weight: 45 lbs with air/hydraulic pump
- Rating: 30 tons force @ 10,000 psi maximum
- Full Cycle Time: Approximately 30 seconds

### Operating Parameters

Reference Crimpsource™ online or appropriate catalog (4660 or 4400) of the Parker division that supplies the hose for detailed crimp specifications as exceptions do occur based on the particular hose type, size, and fitting material.  
[www.parker.com/crimpsource](http://www.parker.com/crimpsource)

For detailed ordering information, please consult price list or contact Parflex® Division.

# MiniKrimp™ Crimping Machine Accessories



## Upright Vise Mount

Part No. 015307

- Machined and bent from high strength steel
- Mount connects to the bottom of the MiniKrimp using four 3/8-16 bolts (not included)
- Once connected, MiniKrimp can be clamped into a vise for operation



## Table Mount

Part No. 015306

- Machined and bent from high strength steel
- Mount connects to the bottom of the MiniKrimp using four 3/8-16 bolts (not included)
- MiniKrimp can then be mounted to a table using the four 3/8" clearance holes on the other side of the plate (bolts not included)



## High Pressure Hose Assembly

Part No. 015309

- Parker 10,000 psi, 1/4" I.D. hose with 3/8" female JIC connections on both ends (PN HP0606060604-72")
- Hose is 6' long
- Hose is used when a flexible connection is required between the MiniKrimp and a hydraulic pressure source



## Replacement Connector

Part No. 015308

- Replacement stainless-steel bent tube rigid connector
- For use with 94C-001-PFD (MiniKrimp Hand Pump Model)



## Replacement Connector

Part No. 025349

- Replacement stainless-steel bent tube rigid connector
- For use with 94C-002-PFD (MiniKrimp Air Over Hydraulic Model)

**Note:** The hydraulic connectors shown on this page are designed exclusively for use with the MiniKrimp. No other connectors are approved for use with the MiniKrimp without expressed written consent from Parker Parflex Division's technical support. Any worn connectors should be replaced immediately.





## High Pressure Hose Assembly

Part No. 045234

- Parker 10,000 psi, 1/4" I.D. hose with quick coupler
- Hose is designed to be used when mounting a hand pump to the 94C-MKS MiniKrimp stand's base

ie: HP Hose Assembly with 3000 Series quick disconnects  
 PN HP0101040604-36 (12" guard) with 3050-2/3010-2 coupler and nippler



## Folding Stand

Part No. 94C-MKS

(See pictures below for configuration examples)

- Lightweight folding stand designed exclusively for the MiniKrimp portable crimper
- Fold up design is easy to store
- Mounting hardware and safety instructions are included
- Patented design



Hand Pump  
MiniKrimp™

Hand Pump  
MiniKrimp™

Air Over Hydraulic  
MiniKrimp™

Air Over Hydraulic  
MiniKrimp™ and  
Folding Stand

# MiniKrimp™ Assembly Detail & Parts List

## Hand Pump Model

Part No.	Description	Qty.
015301	2 Speed Light Weight Hand Pump	1
015302	Hardened Steel Sleeve	1
015303	Custom Cylinder	1
015304	Aluminum Frame	1
015305	Cup Pusher	1
015306	Bent Tube Assembly	1
015310	3/8" x 3/8" Shoulder Bolt	1
015415	Spring Plunger	1
6 CTX-S	3/8" 37° to 1/4" NPT Elbow	1
6-6 CTX-S	3/8" 37° to 3/8" NPT Elbow	1
822011	Die Separator	1
822012	Spring	1
822031	Retention Ring	1
82C-R01-PFD	Silver Die Ring	1
015411	3/8-16 18-8 SS SHCS 2.5" Long	2
015413	1/4-20 18-8 SS Lock Washer	2
015414	1/4-20 18-8 SS Flat Washer	2
015412	1/4-20 18-8 SS SHCS .75" Long	4

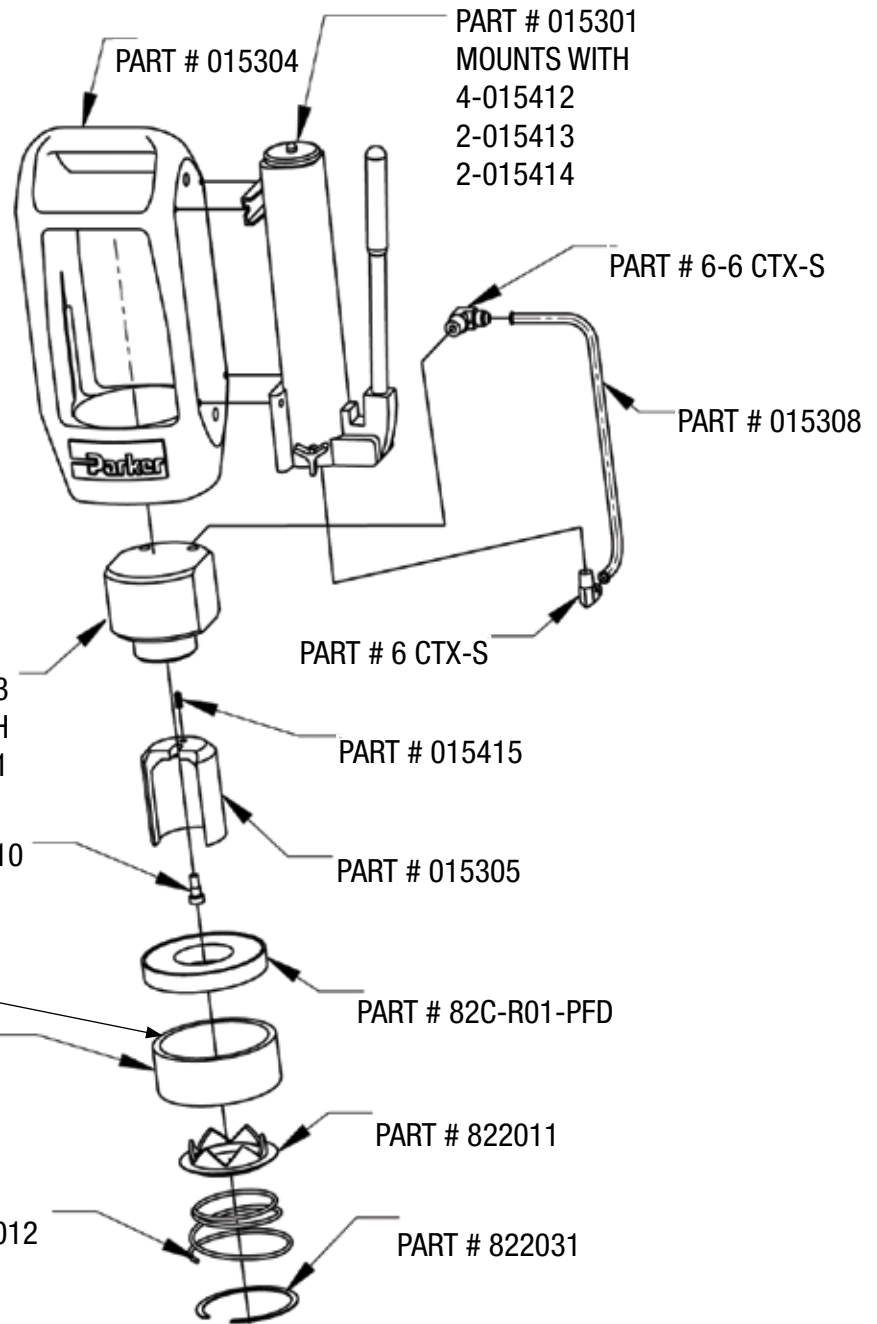

MiniKrimp™ Serial Number



For detailed ordering information, please consult price list or contact Parflex® Division.



# Air Over Hydraulic Model

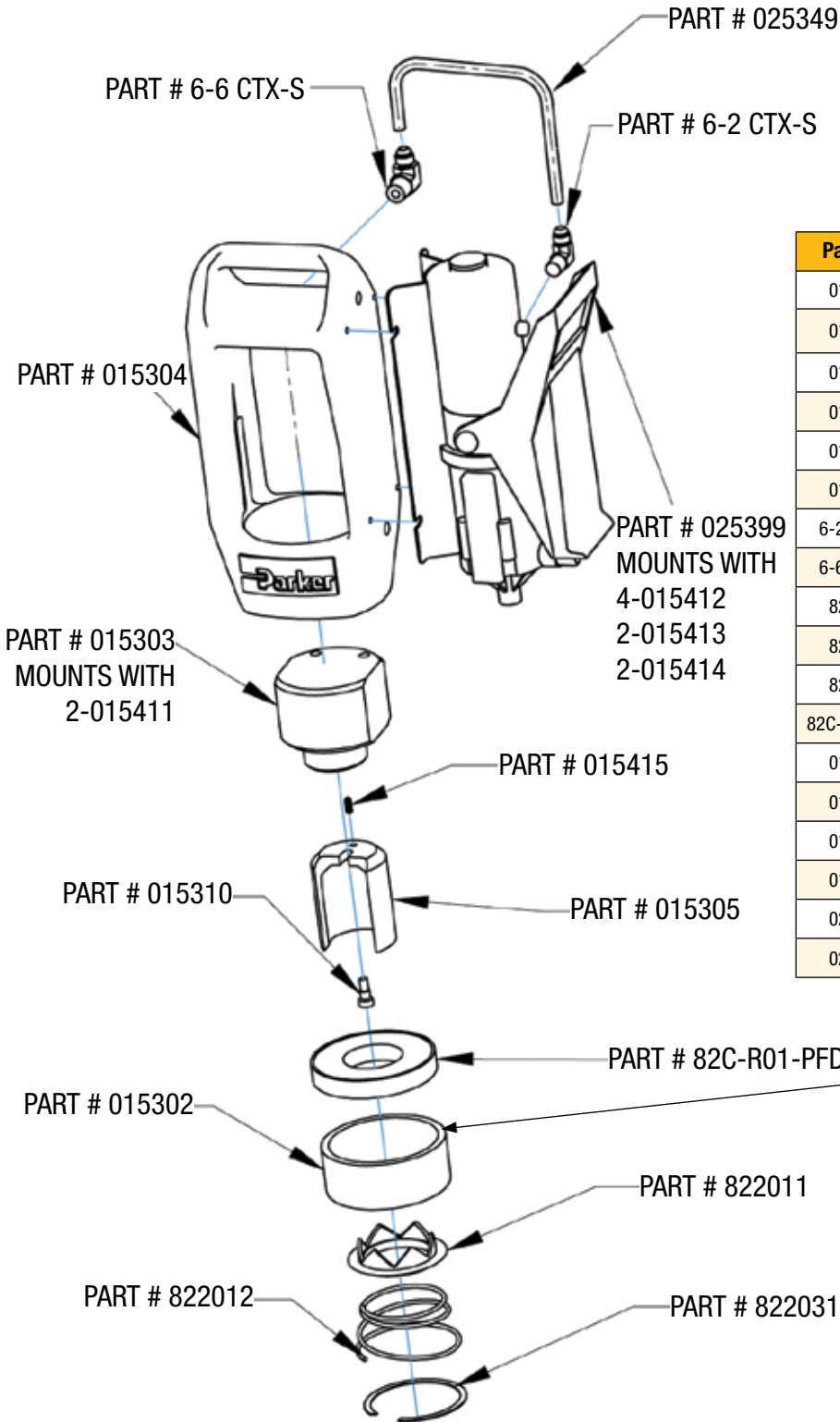

Part No.	Description	Qty.
015302	Hardened Steel Sleeve	1
015303	Custom Cylinder	1
015304	Aluminum Frame	1
015305	Cup Pusher	1
015310	3/8" x 3/8" Shoulder Bolt	1
015415	Spring Plunger	1
6-2 CTX-S	3/8" 37° to 1/8" NPT Elbow	1
6-6 CTX-S	3/8" 37° to 3/8" NPT Elbow	1
822011	Die Separator	1
822012	Spring	1
822031	Retention Ring	1
82C-R01-PFD	Silver Die Ring	1
015411	3/8-16 18-8 SS SHCS 2.5" Long	2
015413	1/4-20 18-8 SS Lock Washer	2
015414	1/4-20 18-8 SS Flat Washer	2
015412	1/4-20 18-8 SS SHCS .75" Long	4
025349	Bent Tube Assembly	1
025399	Air Powered Pump	1

A Hose

B Tubing

C Coiled Air Hose & Fittings

D Transportation

E Fittings

F Tooling, Equipment & Accessories

G General Technical



## Karrykrimp

Part No. 82C-061L-PFD

The Karrykrimp is now available in a modular design with all the familiar Parkrimp System advantages.

The same unit now offers portability and bench mountability.



### Capability

- Crimps most hoses up to 1-1/4 I.D. (check crimpsource for details)

### Features

- Portable, compact rugged design
- Numerous portable power unit options available
- Pivoting pusher design for easy die change out
- Increased height enables longer bent tube fittings to be crimped
- For use with 54, 55, 56, 57, 58, 91, 91N, 92, 93N, CY, MS, SF and HY Series fittings

### Specifications

- Dimensions: 15" wide, 12" deep, 30" high
- Weight: 60 lbs (without power unit)
- Rating: 30 ton force @ 10,000 psi maximum
- Full Cycle Time: 30 seconds

#### Standard Equipment

Part Number			Description	Individual
82C-CHD-PFD	82C-061L-PFD	82C-KKB-PFD		Part Number
●	●	●	Crimp Head	82C-CHD-PFD
		●	Bench Power Unit Assembly	85C-1PH-PFD
●	●	●	Silver die ring	82C-R01-PFD
●	●	●	Black die ring	82C-R02-PFD
	●		Hose Assembly	85C-00L-PFD
	●		Stand Assembly	85C-STD-PFD

## Karrykrimp Bench Mount

Part No. 82C-KKB-PFD



View Video Tutorial

### Capability

- Crimps most hoses up to 1-1/4 I.D. (check crimpsource for details)

### Features

- Faster cycle times on bench mounted units
- Pivoting pusher design for easy die change out
- Compact bench mount design
- Increased height enables longer bent tube fittings to be crimped
- For use with 54, 55, 56, 57, 58, 91, 91N, 92, 93N, CY, MS, SF and HY Series fittings

### Specifications

- Dimensions: 17" wide, 23" deep, 27-1/2" high
- Weight: 146 lbs
- Rating: 30 ton force @ 10,000 psi maximum
- Full Cycle Time: 11 seconds
- Hydraulic Fluid: AW32 oil

This unit is designed to make about 400 crimps per day and is not designed to be a production crimper. Exceeding these suggested production amounts will significantly reduce the life expectancy of the crimper components.

Note:

Motor is dual voltage, 50/60hz suitable for 208-230/115v, 1ph, 60hz and 220-230/110v, ph, 50hz. Motor can be rewired by a qualified electrician to operate at alternate voltage.

## Karrykrimp 2

Part No. 85C-061L-PFD

The Karrykrimp 2 is now available in a modular design with all the familiar Parkrimp System advantages.

The same unit now offers portability and bench mountability.



### Capability

- Crimps most hoses up to 1-1/4 I.D. (check crimpsource for detail)

### Features

- Portable, compact rugged design
- Numerous portable power unit options available
- Pivoting pusher design for easy die change out
- For use with 54, 55, 57, 58, 91, 91N, 92, 93N, CY, MS, SF and HY Series fittings

### Specifications

- Dimensions: 14" wide, 14" deep, 31-1/2" high
- Weight: 120 lbs (without power unit)
- Rating: 60 ton force @ 10,000 psi maximum
- Full Cycle Time: 20 seconds

#### Standard Equipment

Part Number			Description	Individual
85C-CHD-PFD	85C-061L-PFD	85C-KKB-PFD		Part Number
●	●	●	Crimp Head	85C-CHD-PFD
		●	Bench Power Unit Assembly	85C-1PH-PFD
●	●	●	Silver die ring	85C-R01-PFD
●	●	●	Black die ring	85C-R02-PFD
	●		Hose Assembly	85C-00L-PFD
	●		Stand Assembly	85C-STD-PFD

## Karrykrimp 2 Bench Mount

Part No. 85C-KKB-PFD



View Video Tutorial



### Capability

- Crimps most hoses up to 1-1/4 I.D. (check crimpsource for detail)

### Features

- Faster cycle times on bench mounted units
- Pivoting pusher design for easy die change out
- Compact bench mount design
- For use with 54, 55, 57, 58, 91, 91N, 92, 93N, CY, MS, SF and HY Series fittings

### Specifications

- Dimensions: 17" wide, 23" deep, 28" high
- Weight: 208 lbs
- Rating: 60 ton force @ 10,000 psi maximum
- Full Cycle Time: 17 seconds
- Hydraulic Fluid: AW32 oil

This unit is designed to make about 400 crimps per day and is not designed to be a production crimper. Exceeding these suggested production amounts will significantly reduce the life expectancy of the crimper components.

Note:

Motor is dual voltage, 50/60hz suitable for 208-230/115v, 1ph, 60hz and 220-230/110v, ph, 50hz. Motor can be rewired by a qualified electrician to operate at alternate voltage.

## Parkrimp 2

Part No. 83C-081-PFD

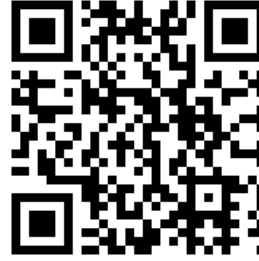

View video tutorial

### Capability

- Crimps hoses up to 2" I.D.  
(reference crimp source for details)

### Features

- Easy to use vertical design
- Crimps full range of Parker hoses from 1/8" through 2" I.D.
- For use with 54, 55, 56, 57, 58, 58H, 91, 91N, 92, 93N, CY, LV, MS, SF and HY Series fittings

### Specifications

- Dimensions: 31" wide, 24" deep, 77" high
- Weight: 842 lbs (Head is 558 lbs and base is 284 lbs)
- Rating: 125 ton force @ 5,000 psi maximum
- Full Cycle Time: 30 seconds without adapter bowl  
20 seconds with adapter bowl
- Hydraulic oil: Enerpac oil only

#### Standard Equipment

Part Number				Description	Individual
83C-001-PFD	83C-081-PFD	83C-002-PFD	83C-082-PFD		Part Number
●	●	●	●	Parkrimp 2 crimper head assembly	83C-080-PFD
●	●			Parkrimp 2 stand assembly with 230/460 volt, 3 phase, 50/60 Hz power unit (wired for 230 volt)	83C-S40-PFD
		●	●	Parkrimp 2 stand assembly with 230 volt, 1 phase, 50/60 Hz power unit	83C-S20-PFD
●	●	●	●	Adapter bowl	83C-OCB-PFD
●	●	●	●	Spacer ring	83C-R02-PFD
●	●	●	●	Spacer Plate	83C-R02H-PFD



For detailed ordering information, please consult price list or contact Parflex® Division.

# Crimper Pumps

## Air/Hydraulic Pump

Part No. 82C-0AP-PFD

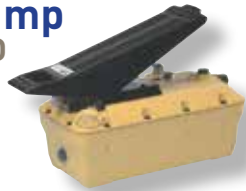

(for use with the MiniKrimp, Karrykrimp and Karrykrimp 2)

Lightweight pump operates with 80-110 psi shop air pressure and delivers 10,000 psi

- Length: 15"
- Width: 6"
- Height: 6"
- Intake Port Size: 1/4" NPTF
- Output Port Size: 3/8" NPTF
- Weight: 14 lbs
- Hydraulic Fluid: Enerpac oil only

## Air/Hydraulic Pump

Part No. 025399



(for use with the MiniKrimp)

Lightweight pump operates with 80-110 psi shop air pressure and delivers 10,000 psi

- Length: 13"
- Width: 4-1/2"
- Height: 5"
- Intake Port Size: 1/4" NPTF
- Output Port Size: 1/8" NPTF
- Weight: 12 lbs.
- Hydraulic Fluid: Enerpac oil only

## Hand Pump

Part No. 015301



(for use with the MiniKrimp)

Ease of operation hand pump delivers 10,000 psi

- Length: 13-3/8"
- Width: 3-1/4"
- Height: 3-5/8"
- Port Size: 1/4" NPTF
- Weight: 4.7 lbs.
- Hydraulic Fluid: Enerpac oil only

# Swagers



## SQ-101-SW Swager/Mender

- Used for field assembly or repair on Predator S6 and S9 hoses

For detailed ordering information, please consult price list or contact Parflex® Division.

Parker Hannifin Corporation | Parflex® Division | Ravenna, Ohio | [parker.com/pfd](http://parker.com/pfd)



F-13

A Hose

B Tubing

C Coiled Air Hose & Fittings

D Transportation

E Fittings

F Tooling, Equipment & Accessories

G General Technical

## Hand Pump

Part No. 82C-0HP-PFD



(for use with the MiniKrimp, Karrykrimp and Karrykrimp 2)

Ease of operation hand pump delivers 10,000 psi

- Length: 13-3/8"
- Width: 3-1/4"
- Height: 3-5/8"
- Port Size: 1/4" NPTF
- Weight: 4.7 lbs.
- Hydraulic Fluid: Enerpac oil only

## Hand Pump

Part No. 85C-0HP-PFD



(for use with the MiniKrimp, Karrykrimp and Karrykrimp 2)

Ease of operation hand pump delivers 10,000 psi

- Length: 29"
- Width: 13"
- Height: 11"
- Port Size: 3/8" NPTF
- Weight: 61 lbs
- Hydraulic Fluid: Enerpac oil only

## Electric Pump

Part No. 82C-0EP-PFD



(for use with the MiniKrimp, Karrykrimp and Karrykrimp 2)

Ease of operation electric pump delivers 10,000 psi

- Length: 13"
- Width: 13"
- Height: 15"
- Port Size: 3/8" NPTF
- Weight: 31 lbs
- Hydraulic Fluid: Enerpac oil only
- 115 volt, 1 phase, 50/60 Hz, 9 amp

## Electric Pump

Part No. 85C-0EP-PFD



(for use with the MiniKrimp, Karrykrimp and Karrykrimp 2)

Heavy duty electric pump delivers 10,000 psi at a faster cycle time

- Length: 19"
- Width: 11"
- Height: 17"
- Port Size: 3/8" NPTF
- Weight: 59 lbs
- Hydraulic Fluid: Enerpac oil only
- 115 volt, 1 phase, 50/60 Hz, 20 amp

## Vise Blocks

For Parflex Hose Sizes



Part Number	Hose Size	
	VBS	-3
-4		1/4
-5		5/16
-6		3/8
-8		1/2
VBL	-12	3/4
	-16	1

## Hose Insertion Depth Blocks

Part No. TH9-1-xxx

Part No. TH8-1-xxx



Part Number	Description
TH9-1-55_58	55 & 58 Series. All sizes.
TH9-1-56	56 Series. All sizes.
TH9-1-58H	58H Series. All sizes.
TH9-1-54A	54 Series All sizes.
TH9-1-91N	91N Series. All sizes.
TH9-1-93N_20_32	93N Series. Sizes: -20, -24, -32
TH9-1-93N_6_16	93N Series. Sizes: -6, -12, -16
TH9-1-94_95	94 & 95 Series. All sizes.
TH9-1-CY_SF	CY & SF Series. All sizes.
TH9-1-MS	MS Series. All sizes.
TH9-1-HY	HY Series. All sizes.



# Parflex Parkrimp Dies



Parkrimp dies, specifically engineered for thermoplastic and fluoropolymer hose:

- Linked die segments
- Pre-matched and assembled
- Fitting size color coded

Color Code	
Size	Color
-1.5	GR
-2	BR
-3	GR
-4	R
-5	P

Color Code	
Size	Color
-6	Y
-8	BL
-10	O
-12	G
-16	B

Color Code	
Size	Color
-20	W
-24	R
-32	G

Parkrimp Approved Silver Die Rings	
Machine	Approved Die
Parkrimp 2	NA*
Karrykrimp and MiniKrimp	82C-R01-PFD
Karrykrimp 2	85C-R01-PFD

\*No additional silver die rings required.

**Note:** 1) Parflex dies have been designed for use with the silver die ring. Silver die rings are to be used with all Parflex hoses unless otherwise specified.

2) For most Parker products, Crimp Die information and selection charts can be found online at [www.parker.com/crimpsource](http://www.parker.com/crimpsource). Access instructions are on pg. G-13.

## Die Racks



### Die Storage Rack

Part No. 80C-0DR-PFD/83C-0DR-PFD

- Holds small and large Parkrimp dies
- Can be bolted together to a work bench

Description	Part No.
Storage 3 small dies	80C-0DR-PFD
Storage 2 large dies	83C-0DR-PFD



### Swivel Die Rack

Part No. 80C-SDR-XXXX-PFD

- Holds up to 30 Parkrimp dies
- Powder coated, heavy duty steel construction
- Consist of base unit and up to 5 circular holders
- Floor or bench mounted

Description	Part No.
Swivel Die Rack and Small Die Holder	80C-SDR-SM-PFD
Swivel Die Rack and Large Die Holder	80C-SDR-LG-PFD
Swivel Die Rack Base	80C-SDR-BASE-PFD

For detailed ordering information, please consult price list or contact Parflex® Division.

# Conversion Kits



## Hydraulic Press Kit

### Specifications

- Required Height from Press Base to Press Ram: 10 inches
- Required Width of Bowl Diameter: 5 inches
- Bowl Rating: 30 tons force maximum
- Minimum Required Press Capacity: Hose Size 1/4" to 1/2" needs a 20 ton press  
Hose size 5/8" to 1-1/4" needs a 30 ton press

### Standard Equipment

Each component must be ordered separately	Individual
Description	Part Number
Bowl Assembly	8PC-030-PFD
Pusher	8PC-00P-PFD
Silver Die Ring	81C-R01-PFD
Black Die Ring	81C-R02-PFD



## Weatherhead Conversion Kit

Weatherhead T-400 crimper to utilize Parker Parkrimp No-Skive fittings.

### Standard Equipment

Each component must be ordered separately	Individual
Description	Part Number
Bowl Assembly	8PC-030-PFD
Pusher	8PC-00P-PFD
Silver Die Ring	81C-R01-PFD
Black Die Ring	81C-R02-PFD



## Gates Conversion Kit

Convert Gates 701, 703 and 707 bottom loading crimpers to utilize Parker Parkrimp No-Skive fittings.

### Standard Equipment

Each component must be ordered separately	Individual
Description	Part Number
Bowl Assembly	8PC-030-PFD
Silver Die Ring	81C-R01-PFD
Black Die Ring	81C-R02-PFD

# Cutting Tools



## Hose Cut-Off Machine Part No. 332T-115V-PFD

### Features

- For quick, easy cutting of spiral reinforced hose up to 1-1/4" I.D.
- Moving parts shielded by guards

### Specifications

- Dimensions: 13" wide x 26" long x 22" high
- Shipping Weight: 71 lbs.

### Standard Equipment

Part Number	Description	Individual Part Number
332T-115V-PFD	Hose Cut-Off Machine with 1-1/2 HP, 3450 RPM, 115/230V single phase electric motor wired for 115V	
	Scallop Cutting Blade (8" with 5/8" arbor size)	24398-PFD

### Optional Equipment

Smooth Cutting Blade (580661-PFD)



## Push-Lok Cut-Off & Assembly Tool Part No. 881540-PFD

- Combines hose cutter and toggle action press
- Cuts and assembles Parker 83FR in sizes 1/4" through 3/4" I.D.



## Hose & Tubing Cutter Part No. HTC

- Special V-block design with easy adjustable blade ensures a straight, clean cut
- Minimal flattening of hose/tubing during cutting - Straight, square cut enhances fitting retention
- Cuts up to 1" O.D. hose or tubing (Non-wire reinforced thermoplastic hose and tubing and rubber hose and tubing)
- Replacement blades: HTC-RB



## Hose Cut-Off Tool Part No. TH11-1-PFD

- Designed for quick, easy cutting of textile reinforced hose
- Squarely cuts fiber reinforced hoses in sizes 1/4" through 3/4" I.D.



## Plastic Tube Cutter Part No. PTC

- Razor-edged tube cutter
- Closes automatically, assuring clean and square cuts
- May be used with most plastic tubing up to 5/8" I.D.

Description	Part Number
Replacement Blades.....	PTC-001-RB

For detailed ordering information, please consult price list or contact Parflex® Division.

# Hose Guards

Parker hose guards prolong the life of hoses that are exposed to rugged operating conditions. In addition to protecting the hose from abrasion and cutting, they limit the bending radius which prevents kinking.

## PV - Clear Vinyl Hose Guard

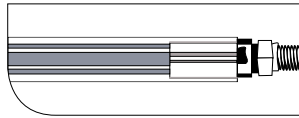

Part Number	Guard I.D.		Standard Length	
	inch	mm	feet	mtr.
#	⊙			
PV97-1	0.44	11	100	30.5
PV139-1	0.56	14	100	30.5
PV1611-1	0.68	17	100	30.5
PV2014-1	0.87	22	50	15.2
PV2420-1	1.25	32	50	15.2
PV3224-1	1.50	38	50	15.2

## HBR - Hose Bend Restrictor (Black Elastomer)

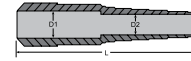

Part Number	Hose Size	L		D1		D2	
		inch	mm	inch	mm	inch	mm
#	⊙						
HBR-4	1/4	6	5	127	.600	15	.500
HBR-6	3/8	10	6	152	.640	16	.625

Parker reserves the right to change dimensions and performance parameters without notice.

## 5CNG/CNGLT - Black Vinyl CNG Hose Guard

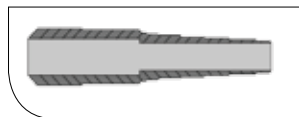

Hose Part Number	Hose Guard Part Number
#	#
5CNG-3	CNGG5-3
5CNG-4	CNGG5-4
5CNG-6	HBR-6
5CNG-8	CNGG5-8
5CNG/CNGLT-12	CNGG5-12
5CNG/CNGLT-16	CNGG5-16

- Use with Parflex CNG hose
- Contact Parflex Division for information on Hose Guard Kits.

# Metallic Spring Guards

Use Spring Guards for protection from abrasion and extreme physical abuse.

## SSG & PSG - Pre-made Spring Guards

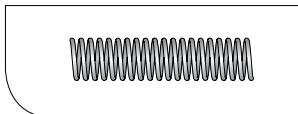

### Plated, hard-drawn steel wire

Part Number	Hose O.D. (reference)		Standard Length	
	inch	mm	inch	mm
#	⊙			
55SSG-3	0.44	11	6	152
55SSG-4	0.55	14	6	152
55SSG-5	0.61	15	6	152
55SSG-6	0.68	17	6	152
55SSG-8	0.83	21	6	152
55SSG-12	1.09	28	7	178

Special configurations available upon request.  
Contact factory.

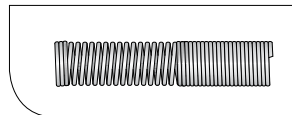

### For CNG Hose (Stainless Steel)

Part Number	Hose Max. O.D.		Standard Length	
	inch	mm	inch	mm
#	⊙			
3PSG-3	0.46	12	5.30	135
3PSG-4	0.54	14	6.25	159
5PSG-4	0.57	14	6.25	159
5PSG-6	0.68	17	6.50	165
5PSG-8	0.90	23	6.50	165

## SG - Steel Spring Guards (Plated, hard-drawn steel wire)

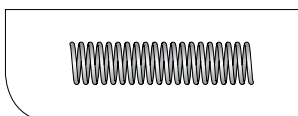

Part Number	Hose O.D. (reference)		Standard Length	
	inch	mm	feet	mtr.
#	⊙			
55SG-3	0.47	12	25	7.6
55SG-4	0.55	14	25	7.6
55SG-5	0.61	16	25	7.6
55SG-6	0.67	17	25	7.6
55SG-8	0.83	21	25	7.6
55SG-12	1.09	28	10	3
55SG-16	1.35	34	10	3
58SG-12	1.18	30	10	3
58SG-16	1.51	38	10	3

## AG - Flat Steel Armor Guards

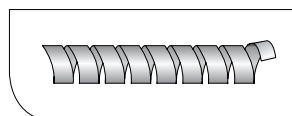

Part Number	Guard I.D.		Standard Length	
	inch	mm	feet	mtr.
#	⊙			
55AG-3	0.47	12	25	7.6
55AG-4	0.55	14	25	7.6
55AG-5	0.61	16	25	7.6
55AG-6	0.67	17	25	7.6
55AG-8	0.83	21	25	7.6
55AG-12	1.09	28	10	3
55AG-16	1.35	34	10	3
58AG-12	1.18	30	10	3
58AG-16	1.51	38	10	3

For detailed ordering information, please consult price list or contact Parflex® Division.

# Guards for PTFE Hoses



AS



2625, 2799

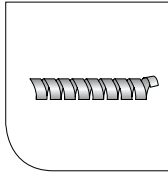

2740, 2613



FS

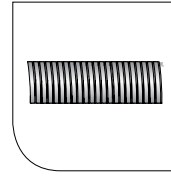

MG



PV

Hose		Max. O.D.	Partek Sleeve	External Round Spring	Internal Round Spring	External Flat Spring	Internal Flat Spring	Fire Sleeve	External Anti-Kink Casing	Clear Vinyl Sleeve
919/929	-3	0.25	-	2625-10	-	2740-10	-	-	-	PV75-1
	-4	0.32	-	2625-11	-	2740-11	-	FS-F-5	MG-038-015C	PV86-1
	-5	0.40	-	2625-14	-	2740-14	-	FS-F-7	MG-044-015C	PV97-1
	-6	0.46	AS-Y-11/AS-B-11	2625-15	-	2740-16	-	FS-F-8	MG-050-015C	PV108-1
	-8	0.56	AS-Y-11/AS-B-11	2625-19	-	2740-19	2613-13CR	FS-F-10	MG-062-015C	PV1310-1
	-10	0.66	AS-Y-13/AS-B-13	2625-22	-	2740-22	2613-16CR	FS-F-12	MG-075-015C	PV1411-1
	-12	0.79	AS-Y-15/AS-B-15	2625-26	-	2740-26	2613-20CR	FS-F-14	MG-081-015C	PV1814-1
	-16	1.05	AS-Y-17/AS-B-17	2625-34	-	2740-34	2613-28CR	FS-F-20	MG-112-015C*	PV2218-1
	-20	1.32	AS-Y-22/AS-B-22	2625-44	-	2740-44	2613-37CR	FS-F-24	MG-144-015C	-
939	-4	0.48	AS-Y-11/AS-B-11	2625-16	-	2740-18	-	FS-F-10	-	-
	-6	0.59	AS-Y-13/AS-B-13	2625-20	-	2740-20	-	FS-F-11	-	-
	-8	0.75	AS-Y-15/AS-B-15	2625-25	-	2740-25	-	FS-F-14	-	-
	-10	0.88	AS-Y-17/AS-B-17	2625-29	-	2740-30	-	FS-F-16	-	-
	-12	1.09	AS-Y-19/AS-B-19	2625-36	-	2740-36	-	FS-F-20	-	-
	-16	1.33	AS-Y-27/AS-B-27	2625-44	2799-16CR	2740-44	-	FS-F-24	-	-
	-20	1.75	AS-Y-35/AS-B-35	2625-58	2799-20CR	2740-58	-	FS-F-32	-	-
	-24	2.05	AS-Y-39/AS-B-39	2625-67	2799-24CR	2740-70	-	FS-F-38	-	-
	-32	2.56	AS-Y-47/AS-B-47	2625-83	2799-32CR	2740-83	-	FS-F-48	-	-
943	-6	0.49	AS-Y-11/AS-B-11	2625-17	-	2740-18	-	FS-F-10	-	-
	-8	0.62	AS-Y-13/AS-B-13	2625-21	-	2740-21	2613-13CR	FS-F-11	-	-
	-10	0.73	AS-Y-15/AS-B-15	2625-24	-	2740-23	2613-16CR	FS-F-14	-	-
	-12	0.99	AS-Y-17/AS-B-17	2625-33	-	2740-35	2613-20CR	FS-F-18	-	-
	-16	1.39	AS-Y-27/AS-B-27	2625-45	-	2740-46	2613-28CR	FS-F-24	-	-

NOTE: \*MG-112-015C to be used on 919-16 only.  
 Partek sleeves come in yellow and black.  
 All internal guards are fabricated from 300 series stainless steel.  
 All external guards are plated steel.



For detailed ordering information, please consult price list or contact Parflex® Division.



# Spring Guards & Armor Guards

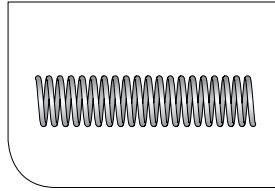
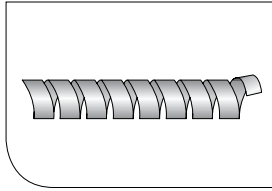

Hose Style	Armor Guards/Spring Guards								
	55AG-3 55SG-3	55AG-4 55SG-4	55AG-5 55SG-5	55AG-6 55SG-6	55AG-8 55SG-8	55AG-12 55SG-12	55AG-16 55SG-16	58AG-12 58SG-12	58AG-16 58SG-16
510A/510C/518C/518D	-2,-3	-4	-5	-6	-8		-16	-12	
515H	-3,-4	-5	-6		-8				
520N/528N	-3	-4	-5	-6	-8	-10			
526BA	-3	-4		-6					
527BA	-3		-4						
53DM/538DM	-3	-4		-5	-6	-8,-10		-12	
540N/540P/540R	-2,-3	-4	-5	-6	-8	-12			
55LT	-2,-3	-4	-5	-6	-8	-12			
560/560R	-3	-4	-5	-6	-8	-10		-12	
563		-4		-6	-8				
56DH/568DH	1.5,-2								
569			-4						
573X	-3								
575X	-3	-4		-6	-8			-12	
580N/H580N/588N				-4	-6	-8,-10		-12	-16
590		-3	-4	-6	-8	-10		-12	-16
593								-12	-16
83FR		-4		-6	-8	-12			
1035A		-4		-6					
1035HT	-3	-4		-6					
B9	-3	-4	-5	-6	-8	-10			
D6			-4	-5	-6	-8,-10	-12		-16
D6R		-4	-5	-6	-8	-10	-12		
H6		-4	-5	-6	-8	-10	-12		
HFS			-4	-5	-6			-12	-16
HFSR		-4	-5	-6	-8	-12	-16		
HFS2			-4		-6	-8,-10		-12	-16
HFS2R			-4	-6	-8			-12	-16
HJK				-4					
HLB	-2,-3								
HTB/M8				-4	-6	-8,-10	-12		-16
HTBR			-4		-6	-8,-10			
MSH		-5		-6					
PTH	-3								
R6			-4		-6	-8		-12	
S5N					-8				
S6/S9							-12		-16
SLH					-8				

For detailed ordering information, please consult price list or contact Parflex® Division.



# PVC Guards



Hose Style	PVC Guards						
	PV97-1	PV139-1	PV1611-1	PV2014-1	PV2218-1	PV2420-1	PV3224-1
510A/510C/518C/518D	-2	-3	-4,-5,-6	-8	-10	-12	-16
515H	-3		-5,-6				
520N/528N		-3	-4,-5	-6,-8	-10		
526BA		-3	-4	-6			
527BA		-3	-4				
53DM/538DM		-3	-4,-5	-6	-8,-10	-12	
540N/540P/540R	-2	-3	-4,-5	-6,-8	-12		
55LT		-3	-4,-5	-6,-8		-12	
560/560R		-3	-4,-5,-6	-8	-10	-12	
563			-4	-6,-8			
56DH/568DH	-1.5, -2						
569			-4				
573X		-3					
575X		-3	-4	-6,-8		-12	
580N/H580N/588N					-8,-10	-12	
590		-3	-4	-6,-8	-10	-12	-16
593						-12	-16
83FR			-4,-6	-8	-12		
1035A			-4	-6			
1035HT		-3	-4	-6			
B9	-3		-4,-5,-6		-10		
D6			-4,-5	-6,-8	-10	-12	
D6R			-4,-5,-6	-8	-10	-12	
H6			-4,-5	-6,-8	-10	-12	
HFS			-4,-5	-6,-8	-12		-16
HFSR			-4,-5,-6	-8	-12		-16
HFS2			-4	-6,-8	-10	-12	-16
HFS2R			-4,-6	-8	-10,-12		-16
HJK			-4				
HLB		-3					
HTB/M8			-4	-6	-8,-10	-12	
HTBR			-4	-6	-8,-10	-12	
MSH			-5,-6				
PTH		-3					
R6			-4	-6	-8	-10	-12
S5N				-8			
S6/S9						-12	-16
SLH				-8	-10	-12	-16



For detailed ordering information, please consult price list or contact Parflex® Division.

# PSG – Parker Spiral Guard



## Features

- High-strength and resilient, Spiral Guard protects hose and cable with superior anti-crush performance
- Exceptionally smooth facing and rounded edges prevent Spiral Guard from getting caught on rough surfaces
- Easy installation and routing
- Low friction interior minimizes wear on hose
- For bundling, organizing and protecting hose and cable, Parflex Spiral Guard is the superior solution for mining operations - In fact, it delivers more advantages than cut pipe or sleeving at a competitive price or less
- Spiral Guard is available in:
  - An MSHA/FRAS approved version for underground mining
  - A standard version (with yellow stripe) for surface applications not requiring fire-resistant, anti-static properties

## Applications



- Mining
- Automotive
- Mobile Equipment

Part Number	Hose O.D. Range		Package Qty.		1-Wire Braid Size		2-Wire Braid Size		Multi-Spiral Size		Weight	
	mm	inch	mtr.	feet	inch	mm	inch	mm	inch	mm	lbs./ft.	kg./mtr.
#	⊙										lbs	kg
PSG 12	10 – 13	.394-.512	20	65.6	-		-		-		.034	.015
PSG 16 FRAS or PSG 16	12 – 17	.472-.669	20	65.6	1/4	6	1/4	6	-		.040	.018
PSG 20 FRAS or PSG 20	16 – 22	.630-.866	20	65.6	3/8	10	1/4 3/8	6 10	3/8	10	.060	.027
PSG 25 FRAS or PSG 25	22 – 28	.866-1.10	20	65.6	1/2 5/8	13 16	1/2 5/8	13 16	1/2 5/8	13 16	.101	.046
PSG 32 FRAS or PSG 32	27 – 33	1.06-1.30	20	65.6	3/4	19	5/8 3/4	16 19	5/8 3/4	16 19	.151	.068
PSG 40 FRAS or PSG 40	33 – 42	1.30-1.65	20	65.6	1	25	1	25	1	25	.235	.107
PSG 50 FRAS or PSG 50	42 – 55	1.65-2.17	20	65.6	1-1/4 1-1/2	32 38	1-1/4	32	1-1/4	32	.268	.122
PSG 63 FRAS or PSG 63	52 – 65	2.05-2.56	20	65.6	2	51	1-1/2	38	1-1/2	38	.402	.182
PSG 75 FRAS or PSG 75	65 – 80	2.56-3.15	10	32.8	-		2	51	2	51	.637	.289
PSG 90 FRAS or PSG 90	80 – 150	3.15-5.91	10	32.8	-		-		-		.771	.350
PSG 110 FRAS or PSG 110	150 – above	5.91-above	10	32.8	-		-		-		1.00	.454

Temperature Range: -148°F to 212°F (-100°C to 100°C)

For detailed ordering information, please consult price list or contact Parflex® Division.

Parker Hannifin Corporation | Parflex® Division | Ravenna, Ohio | [parker.com/pfd](http://parker.com/pfd)



A Hose

B Tubing

C Coiled Air Hose & Fittings

D Transportation

E Fittings

F Tooling, Equipment & Accessories

G General Technical

# Notes

---

---

---

---

---

---

---

---

---

---

---

---

---

---

---

---

---

---

---

---

---

---

---

