



Bulletin AP-316
2020

AIR PREPARATION

Filters & Regulators

316 Stainless Steel



AR-316 SERIES *Stainless Steel Regulator*

The Versa Type AR-316 series of stainless steel regulators and filter regulators are designed to stand up to the harshest environments while providing highly accurate pressure regulation.

Proven 316 stainless steel housing and filter assemblies along with fluorocarbon diaphragm construction make the AR-316 compatible with sour gas and adaptable to off shore environments.

This quality instrument is economical to buy as

well as operate, and provides extremely stable and repeatable control of gas pressure. Over ported internal flow paths helps the unit achieve high flow rates with minimal pressure drop.

The ARFA stainless steel construction is ideal for sour gas and/or corrosive environments and is NACE Compliant meeting sulfide stress cracking material requirements for NACE Standard MR0175. The ARFB model, only the wetted parts are NACE compliant

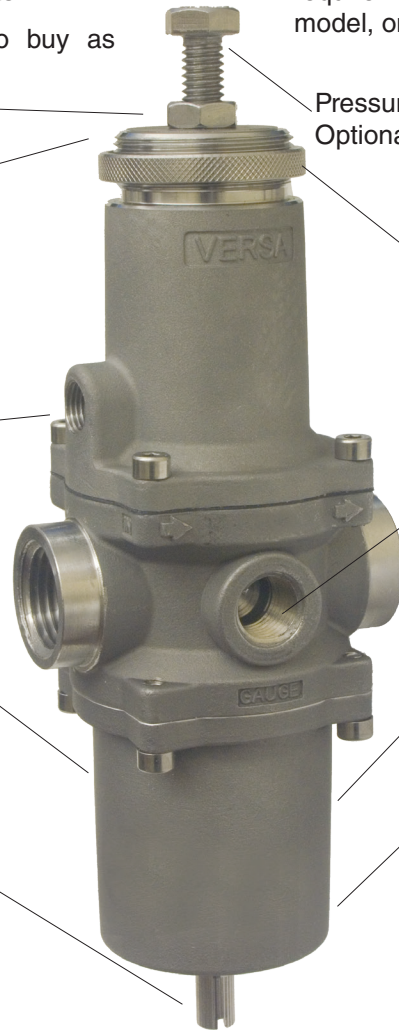

Lock Nut for securing set pressure

Name Plate stainless steel

Pressure Adjusting Bolt
Optional hand knob available

Panel Nut, for bracket or panel mount for 1/4" - 1/2"
Mounting holes supplied on 1" units

1/8" NPT Vent, for piping away vent gases

1/4" NPT Gauge Port (2)
Gauges 2" or 2.5", dry or liquid Filled

Investment Cast 316 Body
Lighter weight, enhances internal design for highest flow.

Filter Bowl, 25 micron filter standard. 5 or 40 micron optional

Manual Drain, shown
Auto drain available

Optional extended volume filter bowl available

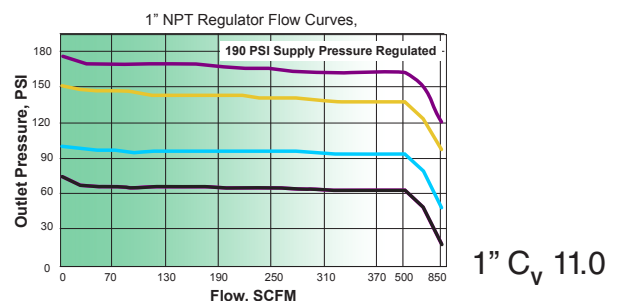
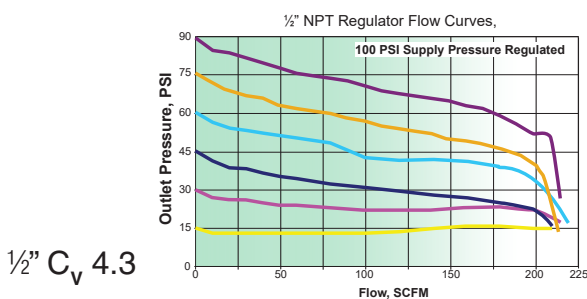
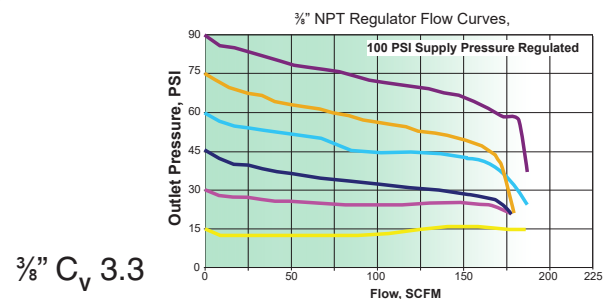
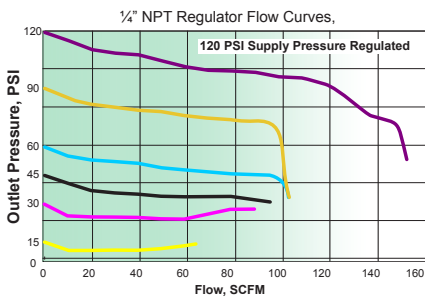

AR-316 SERIES Specifications



Port Size:	
Inlet / Outlet	¼", ⅜" ½" and 1" NPT
Gauge Ports (2)	¼" NPT
Vent	⅛" NPT
AutoDrain (optional)	¼" NPT
Pressure Supply Max: 290 psig* (20.0 bar)*	
Output Ranges:	3-30 psig (0.2 - 2.1 bar) 6-60 psig (0.4 - 4.1 bar) 10-100 psig (0.7 - 6.9 bar) 15-150 psig (1.03 - 10.3 bar)
*With auto drain 150 psi (10.3 bar) Max	
Exhaust Capacity:	1.0 SCFM (1.7 m³/hr) at down stream pressure of 10 psig (0.7 bar) above set point

Filter:	25 micron (5 & 40 optional) Coalescing filter (optional)
Media:	Pneumatic only
Temperature:	5°F to 180°F (-15°C to 82°C) std -60°F to 300°F (-51°C to 149°C) -EP -20°F to 200°F (-29°C to 93°C) -44
Materials:	Body, bonnet, filter, 316 Stainless Steel Diaphragm, seals FKM (fluorocarbon) Valve spring Inconel Adjusting spring Inconel (ARFA) Stainless Steel (ARFB) Name plate 316 Stainless Steel Filter 316 Stainless Steel (washable)

AR-316 SERIES Ordering Information

Size	Pressure	ARFA*		ARNA		ANFA*
		Filter Regulator, Relieving Type**		Regulator Only, Relieving Type**		Filter Only
		Nace 1***	Nace 2***	Nace 1***	Nace 2***	Nace 1***
1/4"	15-150	ARFA-3111-316-†	ARFB-3111-316-†	ARNA-3011-316-†	ARNB-3011-316-†	ANFA-3100-316-†
	10-100	ARFA-3112-316-†	ARFB-3112-316-†	ARNA-3012-316-†	ARNB-3012-316-†	—
	6-60	ARFA-3113-316-†	—	ARNA-3013-316-†	—	—
	3-30	ARFA-3114-316-†	—	ARNA-3014-316-†	—	—
3/8"	15-150	ARFA-4111-316-†	ARFB-4111-316-†	ARNA-4011-316-†	ARNB-4011-316-†	ANFA-4100-316-†
	10-100	ARFA-4112-316-†	ARFB-4112-316-†	ARNA-4012-316-†	ARNB-4012-316-†	—
	6-60	ARFA-4113-316-†	—	ARNA-4013-316-†	—	—
	3-30	ARFA-4114-316-†	—	ARNA-4014-316-†	—	—
1/2"	15-150	ARFA-5111-316-†	ARFB-5111-316-†	ARNA-5011-316-†	ARNB-5011-316-†	ANFA-5100-316-†
	10-100	ARFA-5112-316-†	ARFB-5112-316-†	ARNA-5012-316-†	ARNB-5012-316-†	—
	6-60	ARFA-5113-316-†	—	ARNA-5013-316-†	—	—
	3-30	ARFA-5114-316-†	—	ARNA-5014-316-†	—	—
1"	15-150	ARFA-7111-316-†	ARFB-7111-316-†	ARNA-7011-316-†	ARNB-7011-316-†	ANFA-7100-316-†
	10-100	ARFA-7112-316-†	ARFB-7112-316-†	ARNA-7012-316-†	ARNB-7012-316-†	—

† Suffix option(s) added here as required. See Suffix table on opposite page for options. All models supplied with (2) 1/4" NPT gauge ports. 2 plugs supplied loose. For factory installed plugs add suffix -RPB.

* Filtration: Standard filter is 25 micron. For 5 micron filter change 6th character from 1 to 2. For 40 micron filter change from 1 to 3. For example change ARFA-3111-316 to ARFA-3211-316. Coalescing filter available on ¼" & ½" "Filter Only" units (ANFA's). Change 1 to 4. For example ANFA-3400-316.

* Drain: Standard filter supplied with manual drain. For AutoDrain change 3rd character from F to D. Example change ARFA-3111-316 to ARDA-3111-316. AutoDrain supplied with 1/4" npt drain connection. 150 psi maximum. For increased volume filter bowl on ¼"-½" ARFA & ANFA change part number to ARLA or ANLA.

** Regulator Type: Standard regulator is relieving type. For non-relieving type change 7th character from 1 to 2. For example change ARFA-3111-316 to ARFA-3121-316. Note: For extended filter bowl on ¼", ⅜" or ½" ARFA & ANFA change part number to ARLA or ANLA.

*** NACE 1 ARFA/ARNA/ANFA items are fully NACE compliant. NACE 2 ARFB/ARNB units, only wetted parts are NACE compliant, adjusting spring is 316 stainless steel.

AR-316 SERIES Options/Repair Kits

Options (Suffix Details)	
Suffix Detail	Description
-125B	Adjusting Knob: ¼", ⅜" & ½" only
-EP	Low Temperature service, Ethylene Propylene
-44	Low Temperature service, low temp Buna
-AB	Mounting kit, bracket and nut: ¼", ⅜" & ½" only
-APN	Panel mount nut: ¼", ⅜" & ½" only
-GA	Gauge, 2.5" Diameter*
-APL	Bonnet with integral mounting hubs
-GAG	Gauge, 2.5" Diameter, Liquid Filled*
-GB	Gauge, 2.0" Diameter*
-GBG	Gauge, 2.0" Diameter, Liquid Filled*
-RPB	Gauge ports plugged at factory
-RPL	Gauge mounted at factory, inlet on left
-RPR	Gauge mounted at factory, inlet on right
-APT	Stainless steel tamper-proof cap

* When gauge is specified it is shipped loose along with a plug. For factory installed gauge see options above.

Repair Kits		
Part Number		Description
¼" & ½"	1"	
AR-RK-1	AR7-RK-1	Regulator Kit, Relieving
AR-RK-2	AR7-RK-2	Regulator Kit, Non-Relieving
AR-FK-05	AR7-FK-05	Filter Kit, 5 micron
AR-FK-5-EP	AR7-FK-5-EP	Filter Kit, 5 micron EP seal
AR-FK-25	AR7-FK-25	Filter Kit, 25 micron
AR-FK-40	AR7-FK-40	Filter Kit, 40 micron
ARD-RK-1	ARD7-RK-1	AutoDrain, Kit, Relieving
ARD-RK-2	ARD7-RK-2	AutoDrain, Kit, Non-Relieving

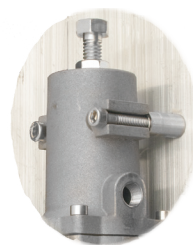

Mounting Hubs
-APL



Tamper Proof Cap
-APT



Black Adjusting Knob
-125B

High Pressure Stainless Steel Components

ARH-316 High Pressure Regulator

Versa's single stage, high pressure regulator is designed to accept up to 6000 psi input and reduce it to a working range of 10 to 500 psi. Making the ARH ideal for first cut Natural Gas high pressure regulator.

The Type ARH-316 Series of stainless steel regulators are designed to stand up to the harshest environments while providing highly accurate pressure regulation. Proven 316L stainless steel housing assembly and stainless steel diaphragm make the ARH-316 ideal for challenging applications such as pipelines, offshore platforms and sour gas media.

This quality instrument is economical to buy as well as operate. The ARH-316 provides extremely stable and repeatable control of gas pressure.

The all 316L stainless steel construction is ideal for sour gas and/or corrosive environments and is NACE Compliant, meeting sulfide stress cracking material requirements for NACE Standard MR0175.

The combined characteristics of high flow and minimal air consumption mean efficient economical operation.

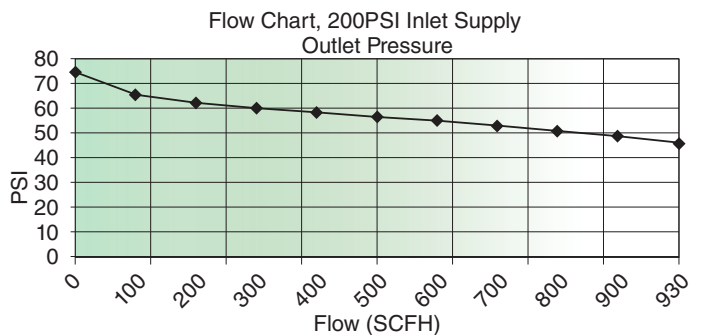
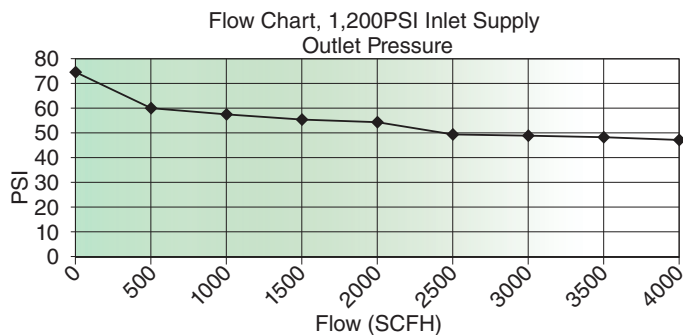
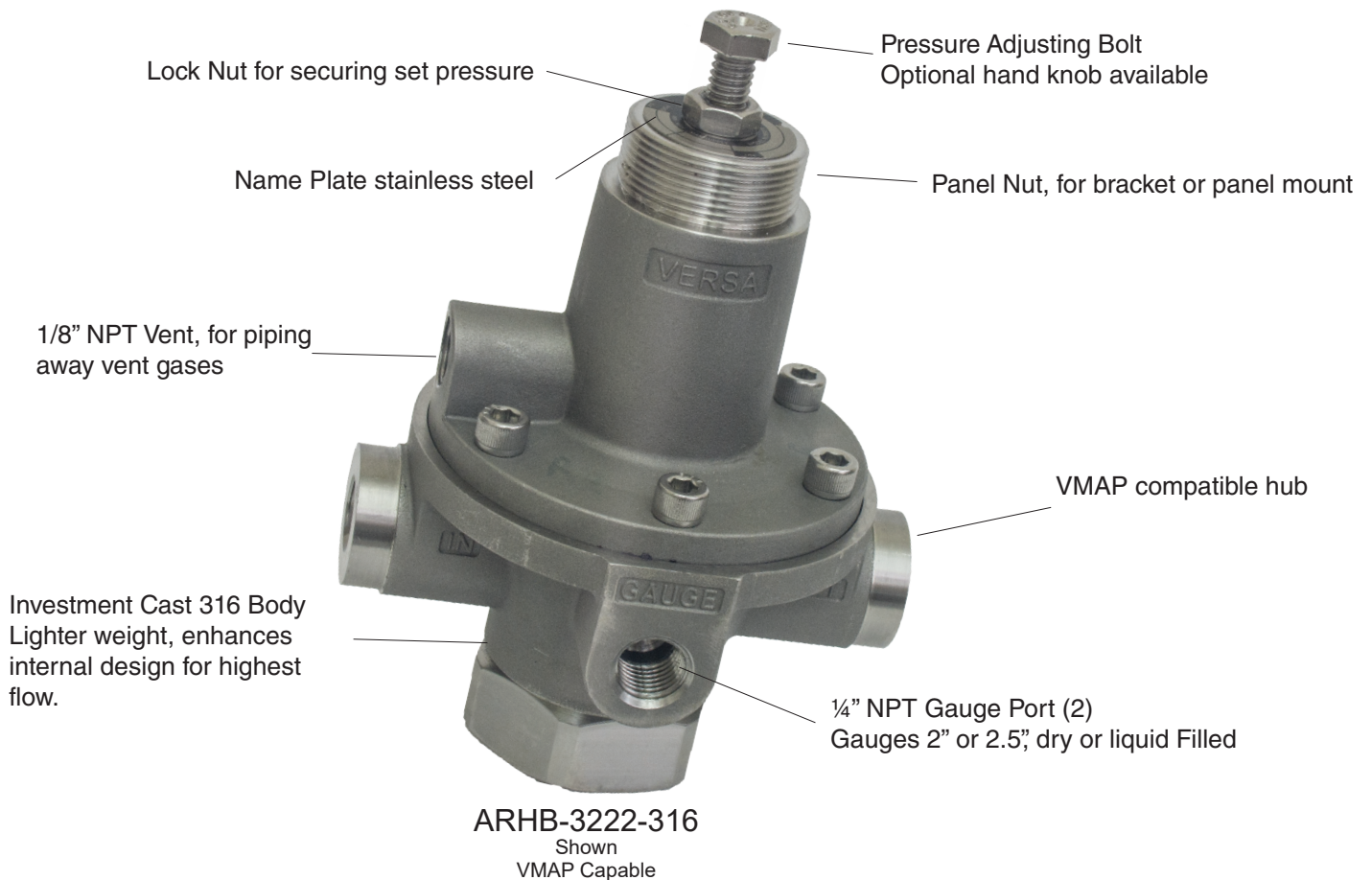

High Pressure Stainless Steel Components



ARH-316 High Pressure Regulator

Filter:	40 mesh	
Port Size:		
Inlet / Outlet	¼" NPT	
Gauge (2)	¼" NPT	
Media:	Pneumatic/Natural Gas	
Flow rate:	0.14 Cv	
Pressure Supply Max:	6000 psig (414 bar)	
Output Ranges:	10-70 psig (0.7-5.2 bar) 50-150 psig (3.4-10.3 bar) 100-250 psig (6.9-17.2 bar) 200-500 psig (13.8-34.5 bar)	

Temperature:	5°F to 180°F (-15°C to 82°C) std -65°F to 300°F (-51°C to 149°C) -EP -20°F to 200°F (-29°C to 93°C) -44
Materials:	
Body:	316L Stainless Steel
Diaphragm:	Stainless Steel
Seals:	FKM (fluorocarbon) (standard) Ethylene Propylene (-EP) (optional) Nitrile (-44) (optional)
Valve spring:	Stainless Steel or Inconel (NACE)
Name plate:	316 Stainless Steel

ARH-316 SERIES Ordering Information

Size	Pressure	Regulator	
		Non Relieving	Part Number*
1/4"	10-75		ARHB-3321-316-†
	50-150		ARHB-3322-316-†
	100-250		ARHB-3323-316-†
	200-500		ARHB-3324-316-†

* For NACE Compliance change ARHB to ARHA.
† Suffix option(s) added here as required. See Suffix Options below.

ARH-316 SERIES Options/Repair Kits

Options (Suffix Details)	
Suffix detail	Description
-AB	Mounting kit, bracket and nut.
-APN	Panel mount nut
-2B	G thread
-125B	Plastic adjusting knob (black)
-EP	Low Temperature service, Ethylene Propylene
-44	Low Temperature service, low temp Buna
-VA	Regulator for VMAP installation

Repair Kits	
Part Number	Description
ARH-RK	Regulator Kit, ¼"
ARH-FK-40	Filter Kit, ¼" 40 mesh

AFH-316 High Pressure Filter



AFHA-3050
Shown
VMAP Capable

Versa's AFH-316 Series high pressure filter is designed to accept up to 6000 psi input and is available in three configurations, 1/4" NPT inline mounting, 1/4" NPT inline mounting with additional outlet port in the cap and manifold mount.

Proven 316L stainless steel housing assembly with two types of filter elements, polyethylene or 316 stainless steel, make the AFH-316 ideal for challenging applications such as pipelines, offshore platforms and sour gas media.

Replacement Element

Filter Material	Part Number
Polyethylene	AFH-090-105-10-RK
Polyethylene	AFH-090-105-25-RK
316 Stainless Steel	AFH-090-105-03-316-RK
316 Stainless Steel	AFH-090-105-10-316-RK
316 Stainless Steel	AFH-090-105-25-316-RK

See Ordering Information table on page 7.

Suffix Options

Suffix detail	Description
-2B	1/4G thread
-EP	Low Temperature service, Ethylene Propylene
-44	Low Temperature service, low temp Buna
-VA	Filter for VMAP installation

Media:	Pneumatic/Natural Gas	Pressure	Supply Max: 0-6000 psig (0-414 bar) 0-4000 psig (0-275 bar) with purge valve 0-1600 psig (0-110 bar) option -VA	Volume:	0.25 oz condensate capacity
Filter Microns:	Polyethylene: 10 or 25 316 Stainless Steel: 3, 10 or 25	Filter Temperature:	Polyethylene: -4°F to 180°F (-20°C to 82°C) std -40°F to 180°F (-40°C to 82°C) -44 & -EP 316 Stainless: -4°F to 250°F (-20°C to 120°C) std -65°F to 250°F (-53°C to 120°C) -44 & -EP	Materials:	Body: 316 Stainless Steel
Port Size:	Inlet/Outlet: ¼" NPT			Seals:	FKM (fluorocarbon) (standard) Ethylene Propylene (-EP) (optional) Nitrile (-44) (optional)
Flow rate:	0.73 Cv			Filter Element:	Polyethylene 316 Stainless Steel
Maximum Differential Pressure:	Polyethylene: 20 psid 316 Stainless: 200 psid				

AR-316 GAUGES

Pressure Range	Gauge Part Number (gauge only)			
	2 Inch (50.8 mm) Ø*		2.5 Inch (63.5 mm) Ø*	
	Standard	Glycerine Filled	Standard	Glycerine Filled
0-60 psi (4.1 bar)	ARGB-060	ARGB-060G	ARG-060	ARG-060G
0-100 psi (6.9 bar)	ARGB-100	ARGB-100G	ARG-100	ARG-100G
0-160 psi (11 bar)	ARGB-160	ARGB-160G	ARG-160	ARG-160G
0-200 psi (13.8 bar)	ARGB-200	ARGB-200G	ARG-200	ARG-200G
0-400 psi (27.6 bar)	ARGB-400	ARGB-400G	ARG-400	ARG-400G
0-1000 psi (69.9 bar)	ARGB-1000	ARGB-1000G	ARG-1000	ARG-1000G

*Nominal size, consult factory for dimensions



Pressure Gauge: Stainless steel case. 1/4" NPT connection (male thread) center back.

Temperature range: Dry: -40°F to 200°F (-40°C to 93°C)
Filled: -4°F to 150°F (-20°C to 66°C)

AR-316 SERIES Dimensions

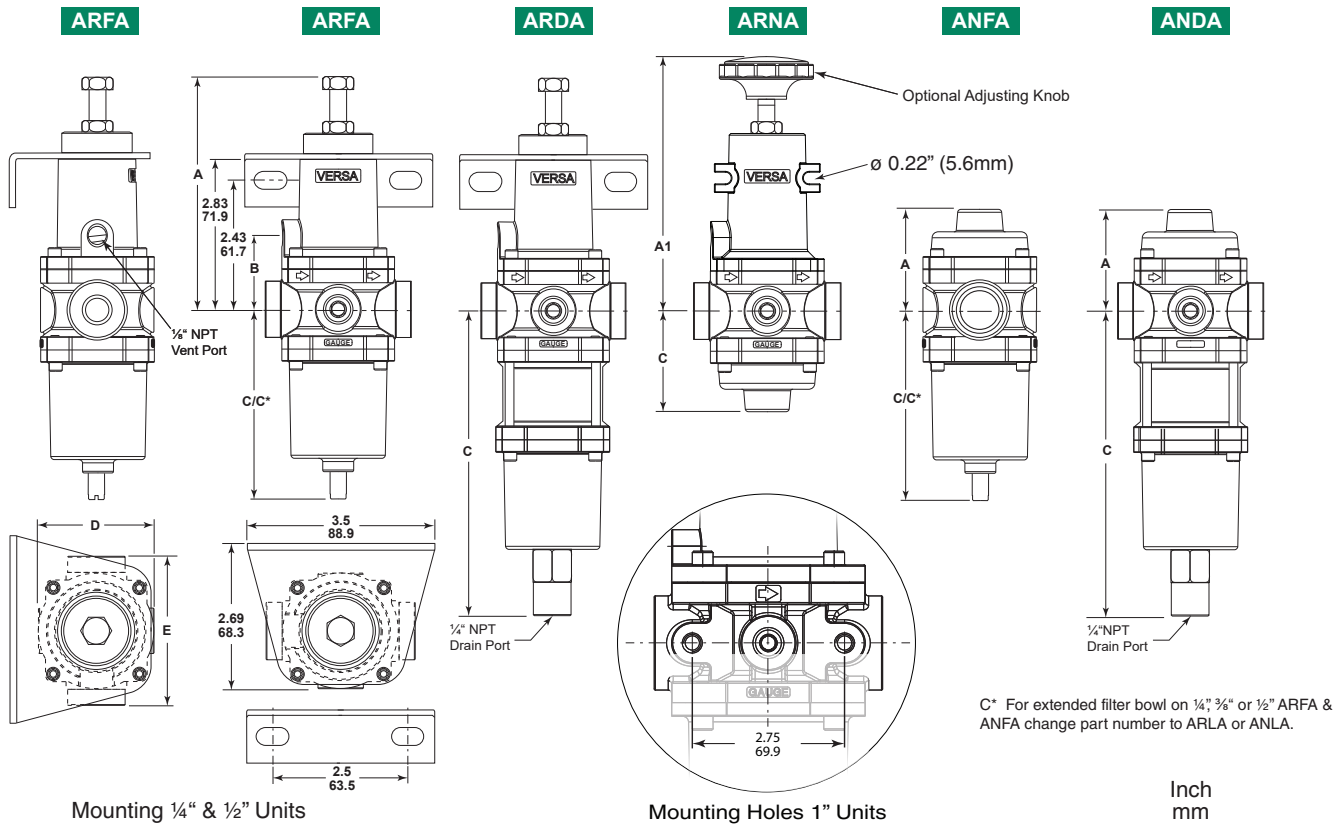

Dimensions																	
Type	Port Size	Weight		A		A1		B		C		C*		D		E	
	(NPT)	lbs	kg	Inch	mm	Inch	mm	Inch	mm	Inch	mm	Inch	mm	Inch	mm	Inch	mm
ARFA	1/4" - 1/2"	2.4	1.1	4.30	109.2	4.89	2.2	1.39	35.3	3.58	90.9	5.22	132.5	2.13	54.1	2.75	69.9
ARDA	1/4" - 1/2"	3.2	1.5	4.30	109.2	4.89	2.2	1.39	35.3	5.75	140.9	—	—	2.13	54.1	2.75	69.9
ARNA	1/4" - 1/2"	2.2	1.0	4.30	109.2	4.89	2.2	1.39	35.3	1.88	47.8	—	—	2.13	54.1	2.75	69.9
ANFA	1/4" - 1/2"	2.2	1.0	1.87	45.8	4.89	2.2	-	-	3.58	90.9	5.22	132.5	2.13	54.1	2.75	69.9
ANDA	1/4" - 1/2"	3.0	1.4	1.87	45.8	4.89	2.2	-	-	5.75	140.9	—	—	2.13	54.1	2.75	69.9
ARFA	1"	8.1	3.67	8.99	228.3	—	—	1.75	44.5	5.19	131.8	—	—	3.50	88.9	4.13	104.8
ARDA	1"	9.2	4.2	8.99	228.3	—	—	1.75	44.5	7.41	188.7	—	—	3.50	88.9	4.13	104.8
ARNA	1"	7.7	3.49	8.99	228.3	—	—	1.75	44.5	5.19	131.8	—	—	3.50	88.9	4.13	104.8
ANFA	1"	6.6	3.0	1.70	43.18	—	—	—	—	5.19	131.8	—	—	3.50	88.9	4.13	104.8
ANDA	1"	7.7	3.49	1.70	43.18	—	—	—	—	7.41	188.7	—	—	3.50	88.9	4.13	104.8

If no bracket is supplied with the 1/4" or 1/2" regulator can be mounted in a 1.36" (35 mm) diameter hole. Maximum thickness is 0.25" (6 mm). See options for panel nut.

ARH-316 SERIES Dimensions



ARHB

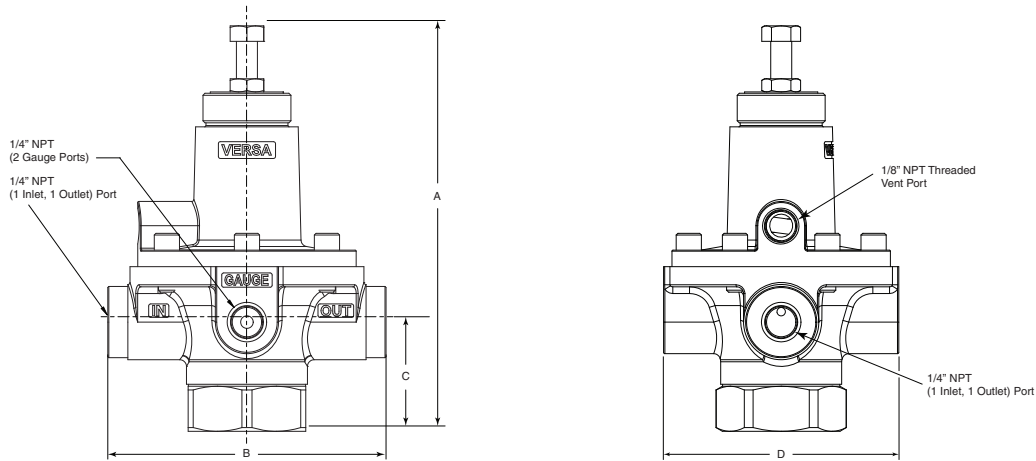

WARNING. Non-Relieving regulators should have a pressure relief valve installed down stream of regulator on dead ended services. This device will prevent excessive build up of pressure protecting systems and components down stream of regulator.

Dimensions											
Type	Port Size (NPT)	Weight		A		B		C		D	
		lbs	kg	Inch	mm	Inch	mm	Inch	mm	Inch	mm
ARHB	1/4"	8	3.6	6.03	153	4.14	105.2	1.63	41.3	3.5	88.9

AFH-316 SERIES Dimensions

AFHA

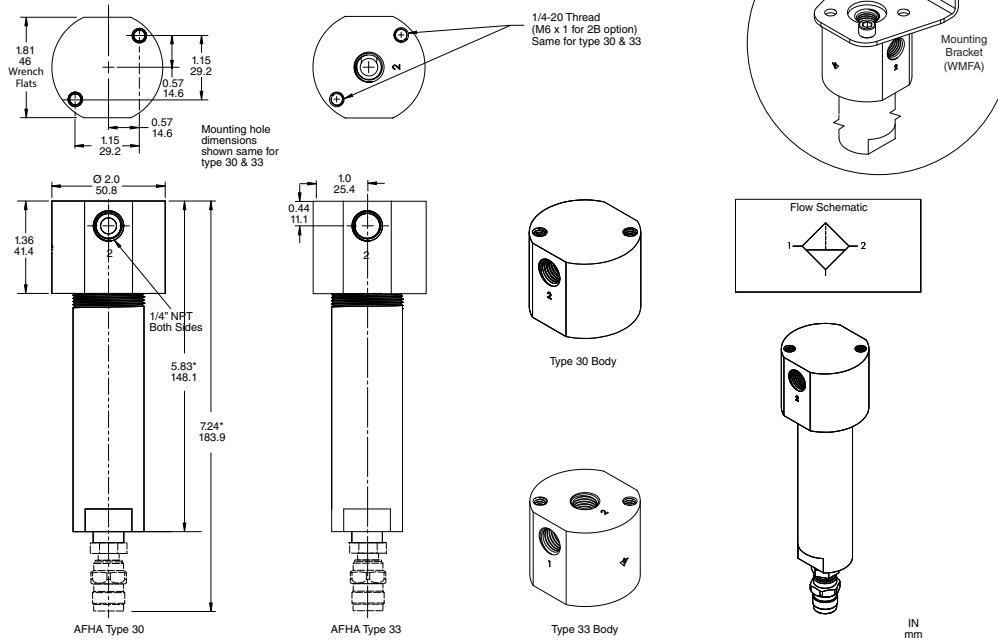

*Allow at least 3" clearance from bottom of filter for element replacement.

Ordering Information							
Series	Port Type	Filter Elements			Drain Options	Material	Options
		Polyethylene	Stainless Steel				
1/4" Side Port	AFHA	30	1 = 10 Micron	3 = 3 Micron	0 = Drain Plugged 1 = Drain Valve	-316	-EP = Low Temp, Ethylene Propylene -2B = 1/4G Threads -44 = Low Temperature, Buna
1/4" Side & Top Port	AFHA	33	2 = 25 Micron	4 = 10 Micron 5 = 25 Micron			

Typical Part Number AFHA-3020-316-44

**Versa
has been
supplying the
oil and gas
industry with
pneumatic
and hydraulic
components
for over 50
years. We
have built a
reputation
for quality
that is
unsurpassed
in the market
for high
performance
solenoids,
pneumatic
relays, resets
and pilot
valves**

**WARNINGS REGARDING THE DESIGN APPLICATION,
INSTALLATION AND SERVICE OF VERSA PRODUCTS**

The warnings below must be read and reviewed before designing a system utilizing, installing, servicing, or removing a Versa product. Improper use, installation or servicing of a Versa product could create a hazard to personnel and property.

DESIGN APPLICATION WARNINGS

Versa products are intended for use where compressed air or industrial hydraulic fluids are present. For use with media other than specified or for non-industrial applications or other applications not within published specifications, consult Versa.

Versa products are not inherently dangerous. They are only a component of a larger system. The system in which a Versa product is used must include adequate safeguards to prevent injury or damage in the event of system or product failure, whether this failure be of switches, regulators, cylinders, valves or any other system component. System designers must provide adequate warnings for each system in which a Versa product is utilized. These warnings, including those set forth herein, should be provided by the designer to those who will come in contact with the system.

Where questions exist regarding the applicability of a Versa product to a given use, inquiries should be addressed directly to the manufacturer. Confirmation should be obtained directly from the manufacturer regarding any questioned application prior to proceeding.

INSTALLATION, OPERATION AND SERVICE WARNINGS

Do not install or service any Versa product on a system or machine without first depressurizing the system and turning off any air, fluid, or electricity to the system or machine. All applicable electrical, mechanical, and safety codes, as well as applicable governmental regulations and laws must be complied with when installing or servicing a Versa product.

Versa products should only be installed or serviced by qualified, knowledgeable personnel who understand how these specific products are to be installed and operated. The individual must be familiar with the particular specifications, including specifications for temperature, pressure, lubrication, environment and filtration for the Versa product which is being installed or serviced. Specifications may be obtained upon request directly from Versa. If damages should occur to a Versa product, do not Operate the system containing the Versa product. Consult Versa for technical information.

**LIMITED WARRANTY DISCLAIMER
AND LIMITATION OF REMEDIES**

Versa's Series products are warranted to be free from defective material and workmanship for a period of ten years from the date of manufacture, provided said products are used in accordance with Versa specifications. Versa's liability pursuant to that warranty is limited to the replacement of the Versa product proved to be defective provided the allegedly defective product is returned to Versa or its authorized distributor. Versa provides no other warranties, expressed or implied, except as stated above. There are no implied warranties of merchantability or fitness for a particular purpose. Versa's liability for breach of warranty as herein stated is the only and exclusive remedy and in no event shall Versa be responsible or liable for incidental or consequential damages.

Versa Products Company Inc.
22 Spring Valley Road
Paramus, New Jersey 07652
USA
Phone: 201-843-2400
Fax: 201-843-2931

Versa BV
Prins Willem Alexanderlaan
1427
7321 GB Apeldoorn
The Netherlands
Phone: 01131-55-368-1900
Fax: 01131-55-368-1909



www.versa-valves.com
email: sales@versa-valves.com