

# General Introduction

## Typical Construction

### Diaphragm Regulators

A pressure reducing regulator is positioned where the high pressure of a medium needs to be reduced and maintained to a lower and stable level. By turning the adjustment handle, the tension of range spring would be changed so as to control the outlet pressure of the regulator.

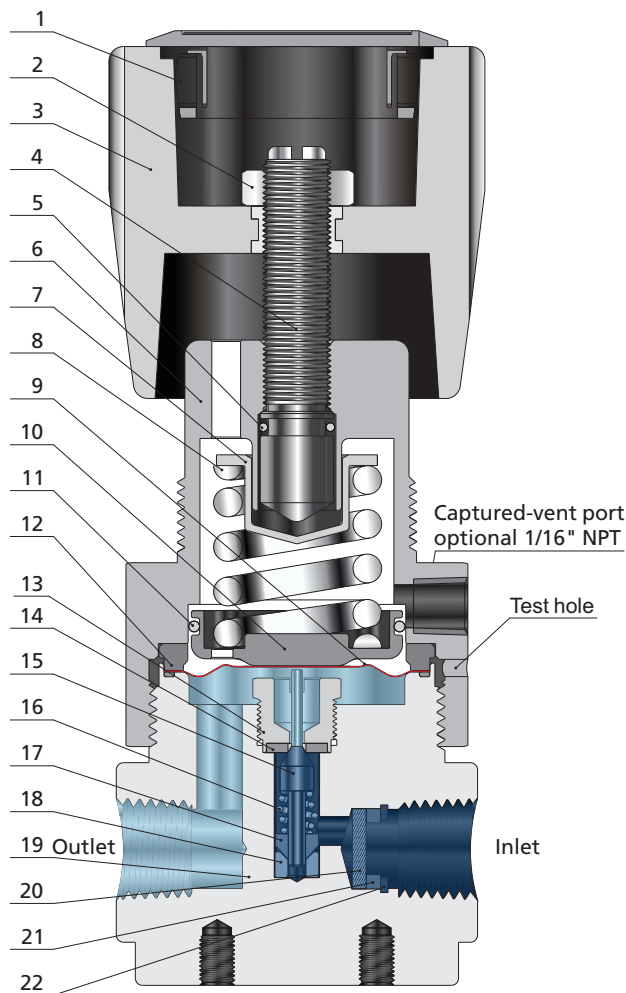

Component		Material/Specification
1	Hole Plug	ABS
2	Stem Nut	C36000/ASTM B16
3	Knob Handle	ABS
4	Stem	C36000/ASTM B16
5	O-ring	Buna-N
6	Bonnet	304 SS/ASTM A479 or Brass
7	Spring Button	304 SS/ASTM A276
8	Range Spring	Alloy
9	Diaphragm	Hastelloy
10	Spring Plate	Aluminium alloy
11	O-ring	Buna-N
12	Seal Ring	304 SS/ASTM A479
13	Seat Retainer	316L SS/ASTM A276
14	Seat	PTFE/ASTM D1430
15	Lift Poppet	316L SS/ASTM A276
16	Poppet Spring	Alloy X-750
17	Poppet Damper	PTFE/ASTM D1710
18	Friction Sleeve	316L SS/ASTM A276
19	Body	316L SS/ASTM A479 or Brass
20	Filter	316L SS
21	Filter Ring	PTFE/ASTM D1710
22	Retaining Ring	316L SS

### Features

- ⦿ Convoluted diaphragm to provide accurate pressure adjustment
- ⦿ Spring loaded
- ⦿ 316L SS filter installed at inlet
- ⦿ Some regulators are fitted with captured-vent, such as FCR-1S, FLR-3 and FLR-5 series and self-venting FCR-2 and FLR-2 series
- ⦿ Users can connect the captured vent port so that the media can be contained or redirected if self-vented or the diaphragm accidentally breaks
- ⦿ Optional sealing material for different gases and purity class
- ⦿ Hastelloy diaphragm to provide higher burst pressure and corrosion resistance
- ⦿ Low leak rates
  - Internal:  $\leq 1 \times 10^{-7}$  mbar·l/s helium
  - External:  $\leq 1 \times 10^{-9}$  mbar·l/s helium

## A-04 Gas Control Equipment

When the regulator is in operation, the inlet pressure ( $F_i$ ) plus the out pressure ( $F_o$ ) should be equal to the downward force on the diaphragm by the compressed spring ( $F_s$ ), namely  $F_i + F_o = F_s$  to reach an equilibrium.

When the outlet pressure ( $F_o$ ) is lower than the set pressure, the poppet would be pushed away from the seat by the excess downward force, allowing more high pressure gas to enter the chamber so as to increase the outlet pressure.

As soon as the outlet pressure ( $F_o$ ) exceeds the set pressure, the excess upstream force shall lift the poppet back to the seat to limit high pressure gas entering, so as to reduce the outlet pressure.

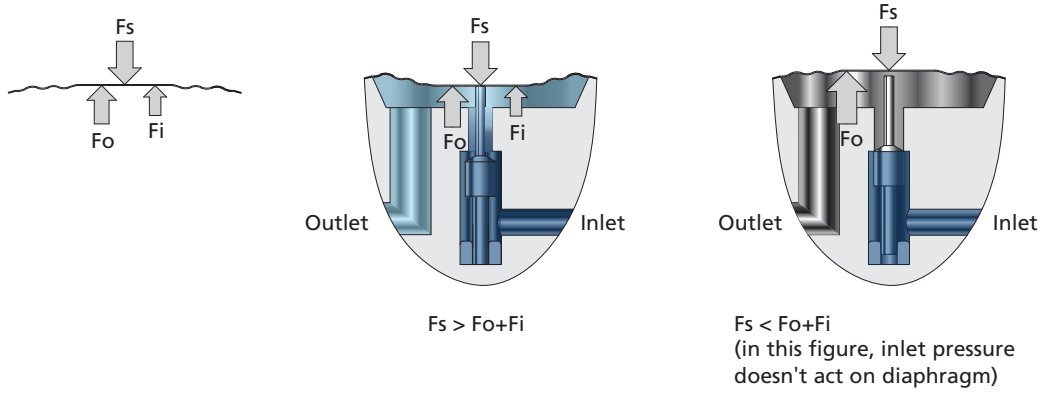

## Dual-stage Diaphragm Regulators

When the inlet pressure ( $P_i$ ) decreases, the outlet pressure ( $P_o$ ) shall increase. Even though the increase may not be significant, the dual-stage regulator would be a better option when more stable pressure required, and the upstream pressure fluctuates violently.

The function of a dual-stage regulator is similar to that of two single-stage regulators in series. The 1st-stage regulator reduces the inlet pressure to an intermediate level for the 2nd-stage regulator to adjust to a constant output, which at the most extent ensures the stability of the outlet pressure.

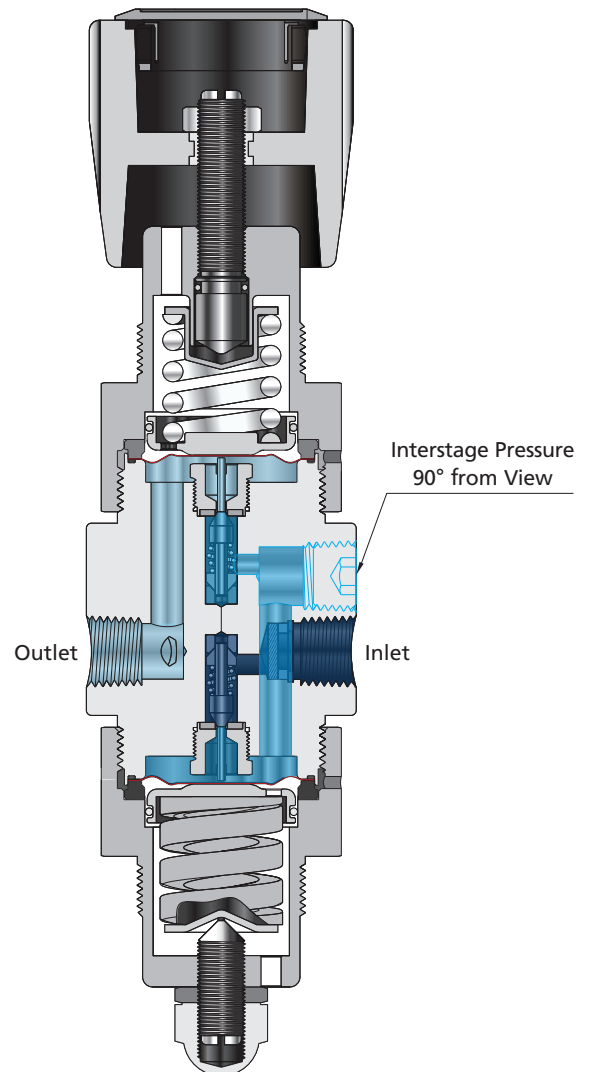
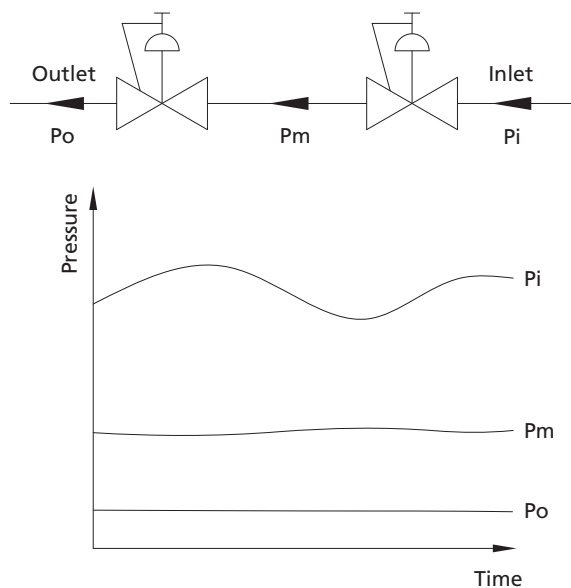

## Piston Regulators

Although diaphragm regulators have many advantages such as precision, sealing effect, cleanliness and etc., in order to ensure sensitivity, the structural strength of the diaphragm regulators is low so as not being able to withstand high pressure. Therefore, it is recommended to utilize the piston regulators for high pressure applications.

A piston regulator has the same working principle as a diaphragm regulator. The key distinction is that the diaphragm is changed to a piston to satisfy the needs for high pressure applications. The inlet pressure of a piston regulator can reach 6000 psig. Its construction is simple and reliable with multiple options of O-rings to fulfill the various requirements of different media.

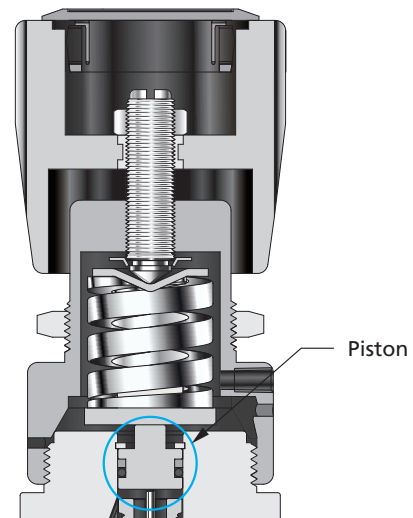

## Series of Products

### Cylinder Pressure Regulators (FCR)

Cylinder pressure regulators are designed to reduce the pressure of the cylinders to a lower level. The regulator is connected to the cylinder normally through a cylinder connection.

### Line Pressure Regulators (FLR)

Line pressure regulators are used to further control the pressure in line.

### Pressure Control Panels (FSR)

Pressure control panels are installed in the gas storage area (cylinder stock room or gas cabinet). They reduce cylinder or tank pressure to the desired line pressure for in-house use. Via the subsequent piping system, the gas will be guided to the point-of-use.

### Changeover Systems (FDR)

There are manual changeover system and automatic changeover system.

Manual changeover system can connect with several independent gas sources at a time. When one gas source is depleted, it could be switched to another source quickly through a shutoff valve.

Automatic changeover system is installed onto gas pipelines which need continuous gas supply. It can connect with two independent gas sources at a time. When the gas source from one side is depleted, it can automatically switch to the gas source from the other side. Subsequently, replacing the exhausted gas source.

### Point-of-use Panels (FPR)

Its function is to most precisely regulate the pressure and shut off at the point-of-use.

# Products Practical Application

## Gas Supply System

Gas Control Equipment

Related Products

Technical References

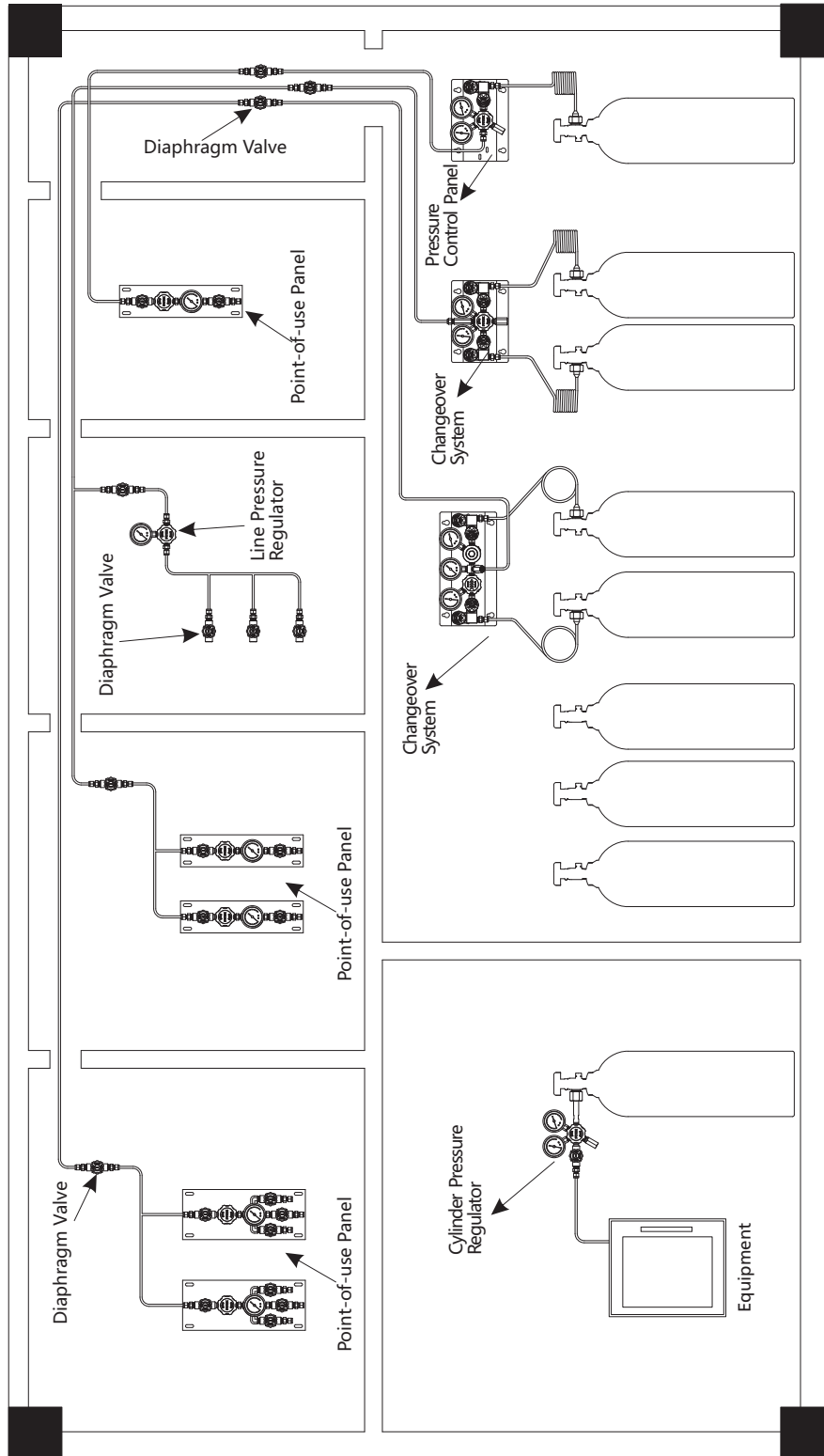

# Selection Guide

		Series																	
		FCR-1	FCR-1S	FCR-2	FCR-1D	FLR-1	FLR-2	FLR-3	FSR-1	FSR-2	FDR-1	FDR-2	FDR-1L	FDR-1T	FPR-1	FPR-1S	BPR-1	BPR-2	
Material	Brass	✓	✓	✓	✓	✓	✓	✓	✓	✓	✓	✓	✓	✓	✓	✓	✓	✓	
	SS	✓	✓	✓	✓	✓	✓	✓	✓	✓	✓	✓	✓	✓	✓	✓	✓	✓	
	Hastelloy	✓			✓	✓									✓				
Pressure Reduction Design	Diaphragm	✓	✓		✓	✓		✓	✓		✓		✓	✓	✓	✓	✓		
	Piston			✓			✓			✓		✓						✓	
	Preset												✓				✓	✓	
	Adjustable	✓	✓	✓	✓	✓	✓	✓	✓	✓	✓	✓	✓	✓	✓	✓	✓	✓	
	Single-Stage	✓	✓	✓		✓	✓	✓	✓	✓	✓	✓	✓		✓	✓			
	Dual-Stage				✓										✓				
Regulator Type	Cylinder	✓	✓	✓	✓														
	In-Line					✓	✓	✓											
	Control Panel								✓	✓	✓	✓	✓	✓					
	Point-of-use														✓	✓			
	Back Pressure																	✓	✓
Maximum Inlet Pressure	6000 psig			✓															
	4500 psig	✓	✓	✓	✓		✓		✓	✓	✓	✓	✓	✓					
	3000 psig	✓	✓		✓		✓	✓	✓	✓	✓	✓	✓	✓					
	1500 psig					✓									✓	✓			
	500 psig					✓		✓											
Control Pressure Range	0~25 psig	✓	✓		✓	✓		✓	✓		✓			✓	✓	✓	✓		
	0~50 psig	✓	✓		✓	✓		✓	✓		✓			✓	✓	✓	✓		
	0~100 psig	✓	✓		✓	✓		✓	✓		✓			✓	✓	✓	✓		
	0~150 psig		✓		✓			✓						✓		✓			
	0~200 psig		✓					✓								✓			
	0~250 psig	✓			✓	✓	✓		✓		✓				✓		✓		
	0~300 psig																	✓	
	0~500 psig	✓					✓		✓		✓				✓			✓	
	0~750 psig			✓			✓			✓		✓							
	0~1000 psig						✓												✓
	0~1500 psig			✓							✓		✓						
	0~2500 psig			✓							✓		✓						
Page No.	A-08	A-11	A-14	A-17	A-20	A-23	A-26	A-44	A-47	A-50	A-53	A-56	A-60	A-64	A-67	A-70	A-73		

See page A-50

# Cylinder Pressure Regulators

## FCR-1 Series General Diaphragm Regulators

### Features

- ⦿ Metal-to-metal seal to minimize external leak
- ⦿ Convoluted diaphragm design to improve regulation precision and cycle life
- ⦿ Applicable to corrosive or toxic gases
- ⦿ With special cleaning and packaging, applicable to oxygen-enriched environments
- ⦿ Adjustable relief pressure
- ⦿ 20 µm filter installed at inlet



Model: FCR-16L-30-100-C330-B-B-00-R-P

### Technical Data

- ⦿ Single-stage regulator
- ⦿ Maximum inlet pressure: 3000 or 4500 psig
- ⦿ Outlet pressure range: 0~25, 0~50, 0~100, 0~250 or 0~500 psig
- ⦿ Material of the internal components:
  - Seat: PCTFE
  - Diaphragm: Hastelloy
  - Filter: 316L
- ⦿ Temperature: -40°F~+165°F (-40°C~+74°C)
- ⦿ Leak rates:
  - Internal:  $\leq 1 \times 10^{-7}$  mbar·l/s helium
  - External:  $\leq 1 \times 10^{-9}$  mbar·l/s helium
- ⦿ Flow coefficient (Cv): 0.06
- ⦿ Weight (regulator only):  $\approx 1.98$  lbs (0.9 kg)
- ⦿ Body ports: 1/4" female NPT for inlet, outlet, gauge and relief valve

### Typical Flow Chart

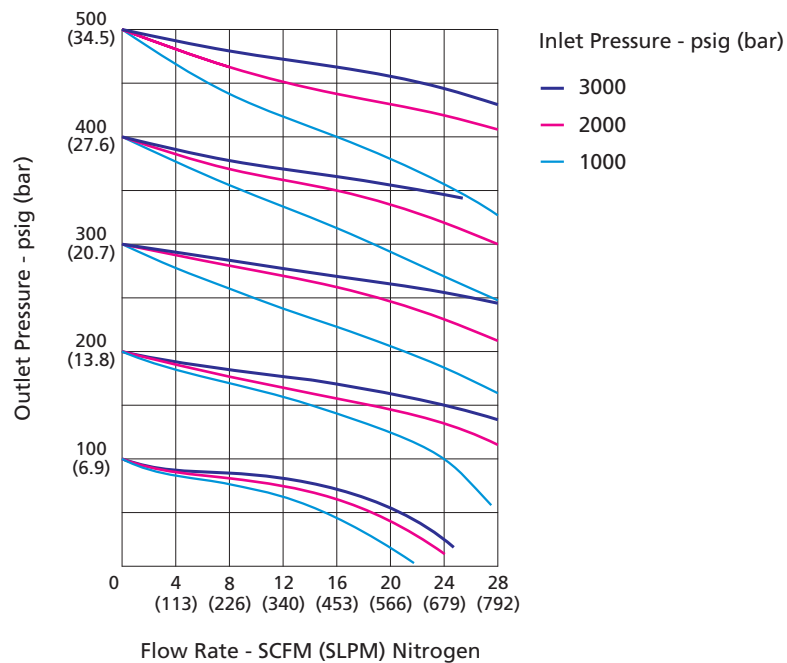

## Dimensions

Dimensions, in inches (millimeters), are for reference only.

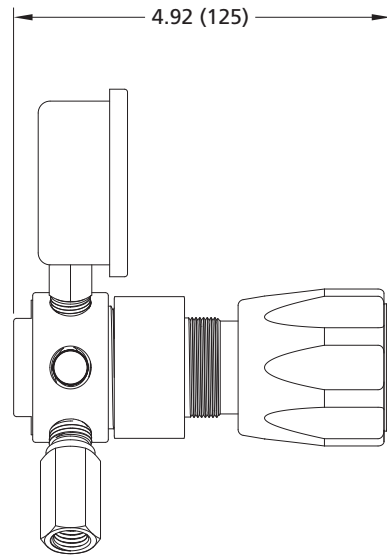
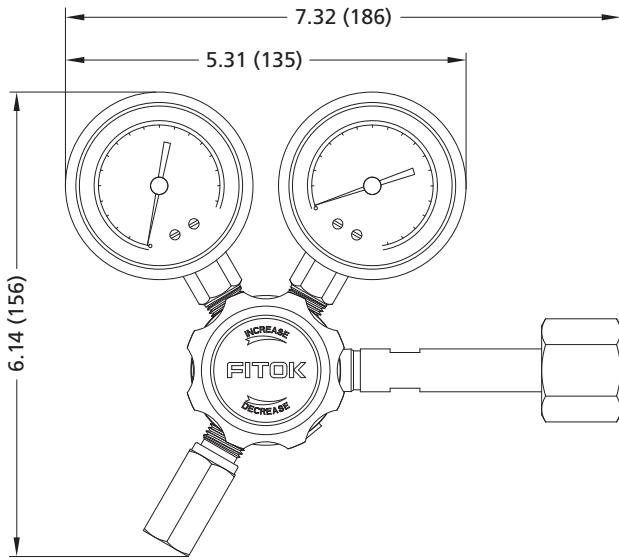

## Port Configurations

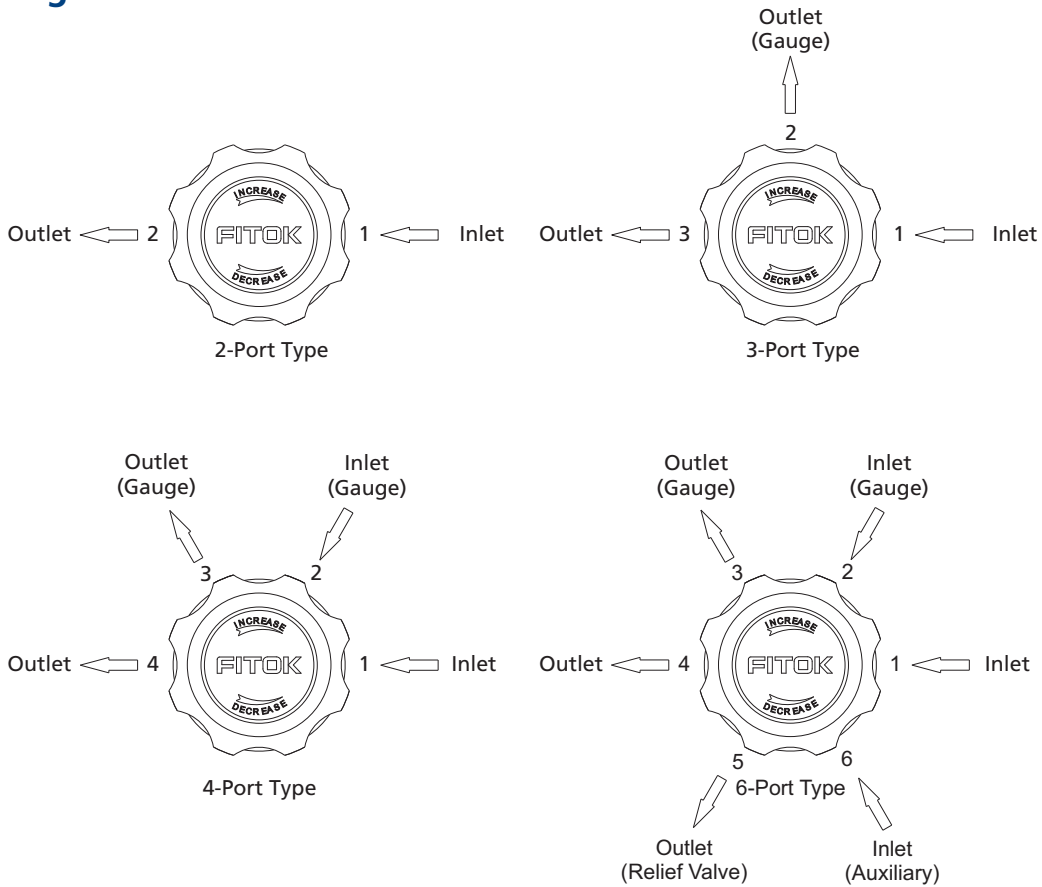

## Part Number Description

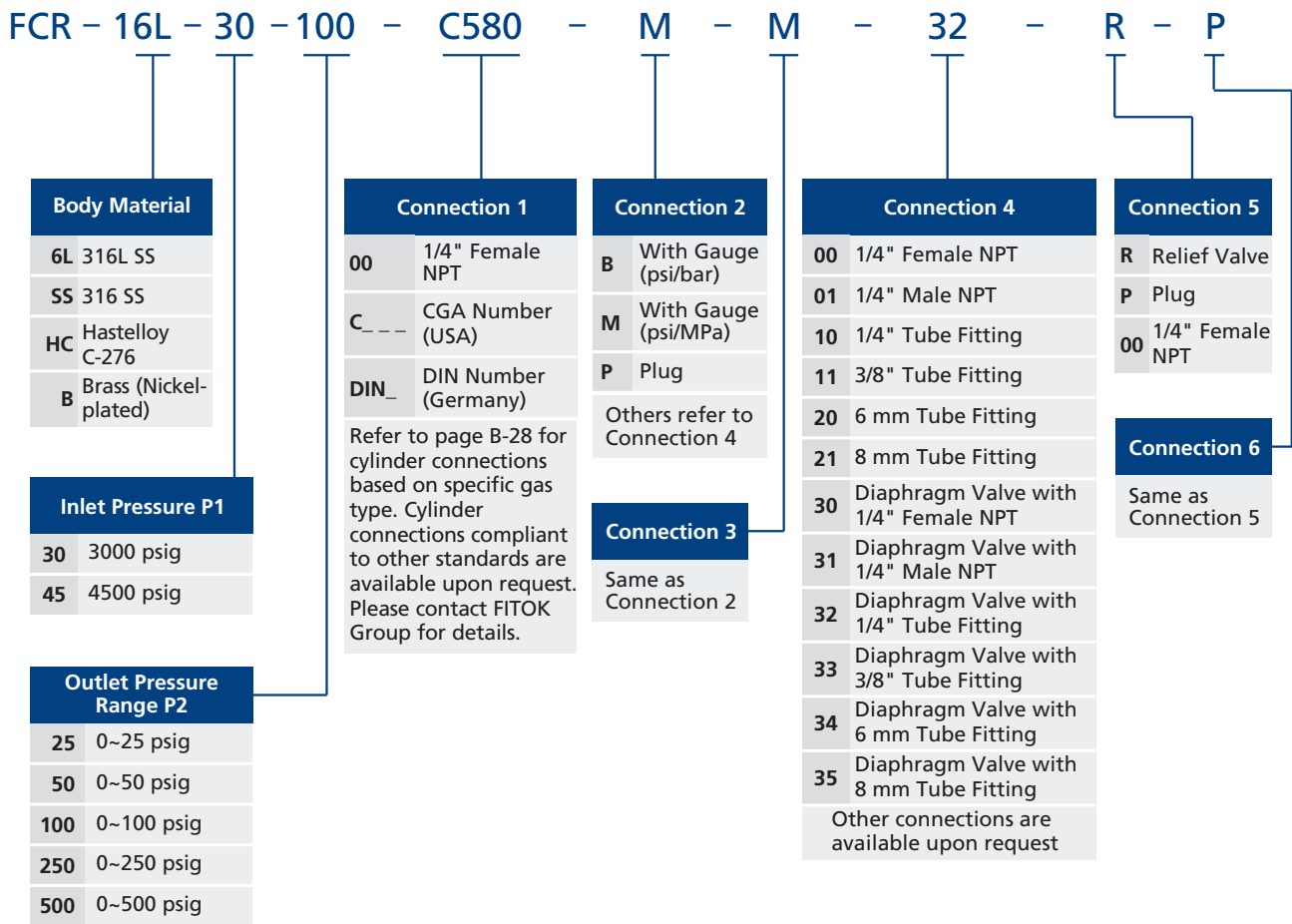

Notes:

1. Most configurations are available.
2. Before ordering, please read **Installation Instructions and Cautions** on A-77.

Examples of part number:

- a. 2-port type (1 in, 1 out): FCR-16L-45-100-C580-00
- b. 3-port type (1 in, 2 out): FCR-15S-30-500-C330-B-00
- c. 4-port type (2 in, 2 out): FCR-1B-45-250-00-B-B-34



# Cylinder Pressure Regulators

## FCR-1S Series Sensitive Diaphragm Regulators

### Features

- ⦿ Large diameter convoluted diaphragm to increase pressure sensitivity and minimize pressure drop
- ⦿ Fitted with captured vent as standard
- ⦿ 316L SS and Brass available for valve
- ⦿ With special cleaning and packaging, applicable to oxygen-enriched environments
- ⦿ Die spring for stable outlet pressure
- ⦿ 20 µm filter installed at inlet



Model: FCR-1S6L-30-50-C580-B-B-00-R-P

### Technical Data

- ⦿ Single-stage regulator
- ⦿ Maximum inlet pressure: 3000 or 4500 psig
- ⦿ Outlet pressure range: 0~25, 0~50, 0~100, 0~150 or 0~200 psig
- ⦿ Material of the internal components:
  - Seat: PCTFE
  - Diaphragm: 316L
  - Filter: 316L
- ⦿ Temperature: -40°F~+165°F (-40°C~+74°C)
- ⦿ Leak rates:
  - Internal:  $\leq 1 \times 10^{-7}$  mbar-l/s helium
  - External:  $\leq 1 \times 10^{-9}$  mbar-l/s helium
- ⦿ Flow coefficient (Cv): 0.06
- ⦿ Weight (regulator only):  $\approx 2.87$  lbs (1.3 kg)
- ⦿ Body ports: 1/4" female NPT for inlet, outlet, gauge and relief valve

### Typical Flow Chart

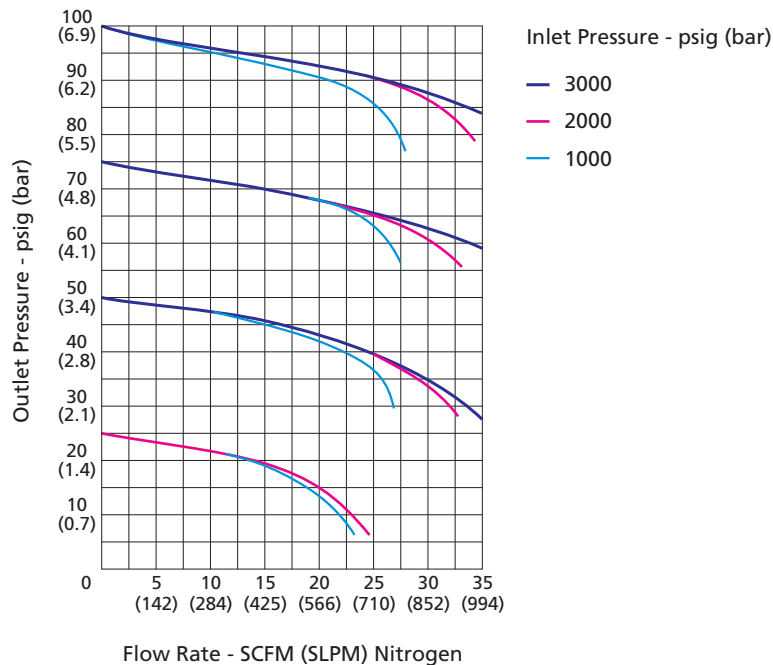

## Dimensions

Dimensions, in inches (millimeters), are for reference only.

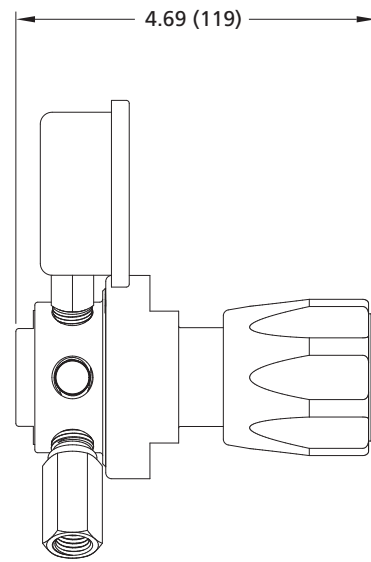
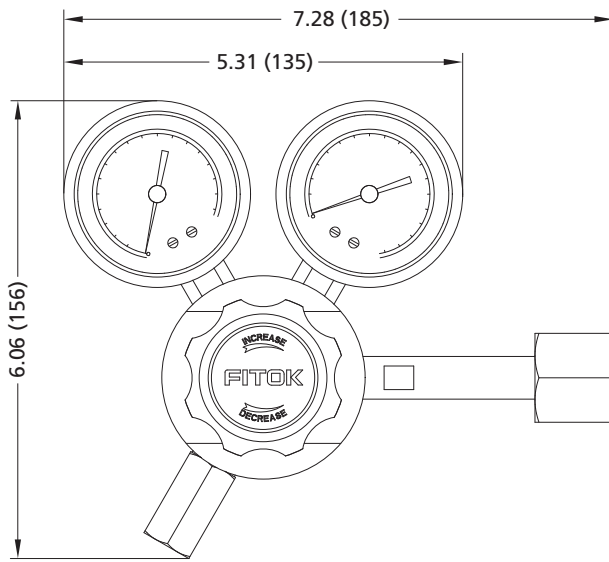

## Port Configurations

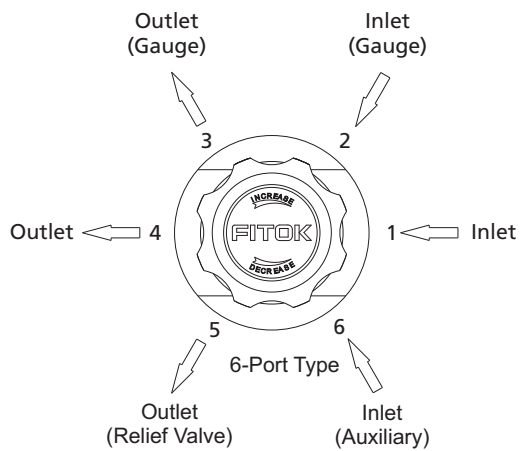
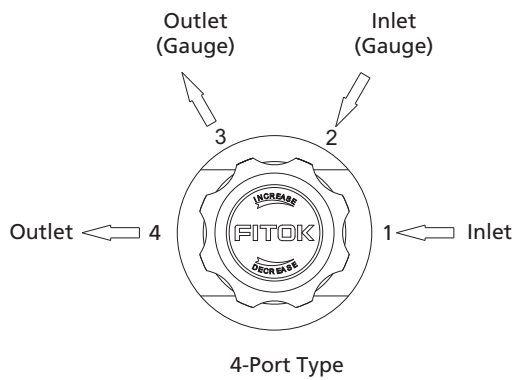
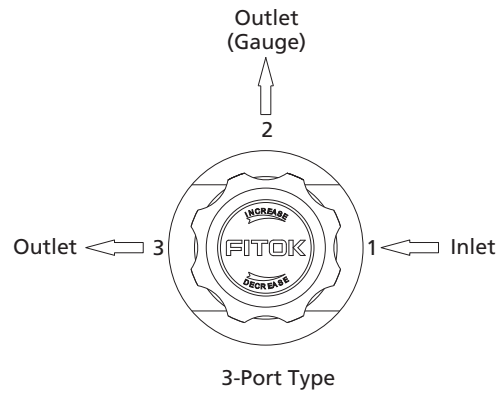
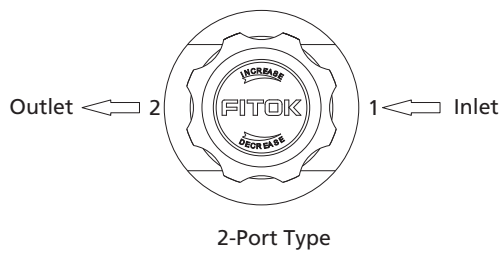

## Part Number Description

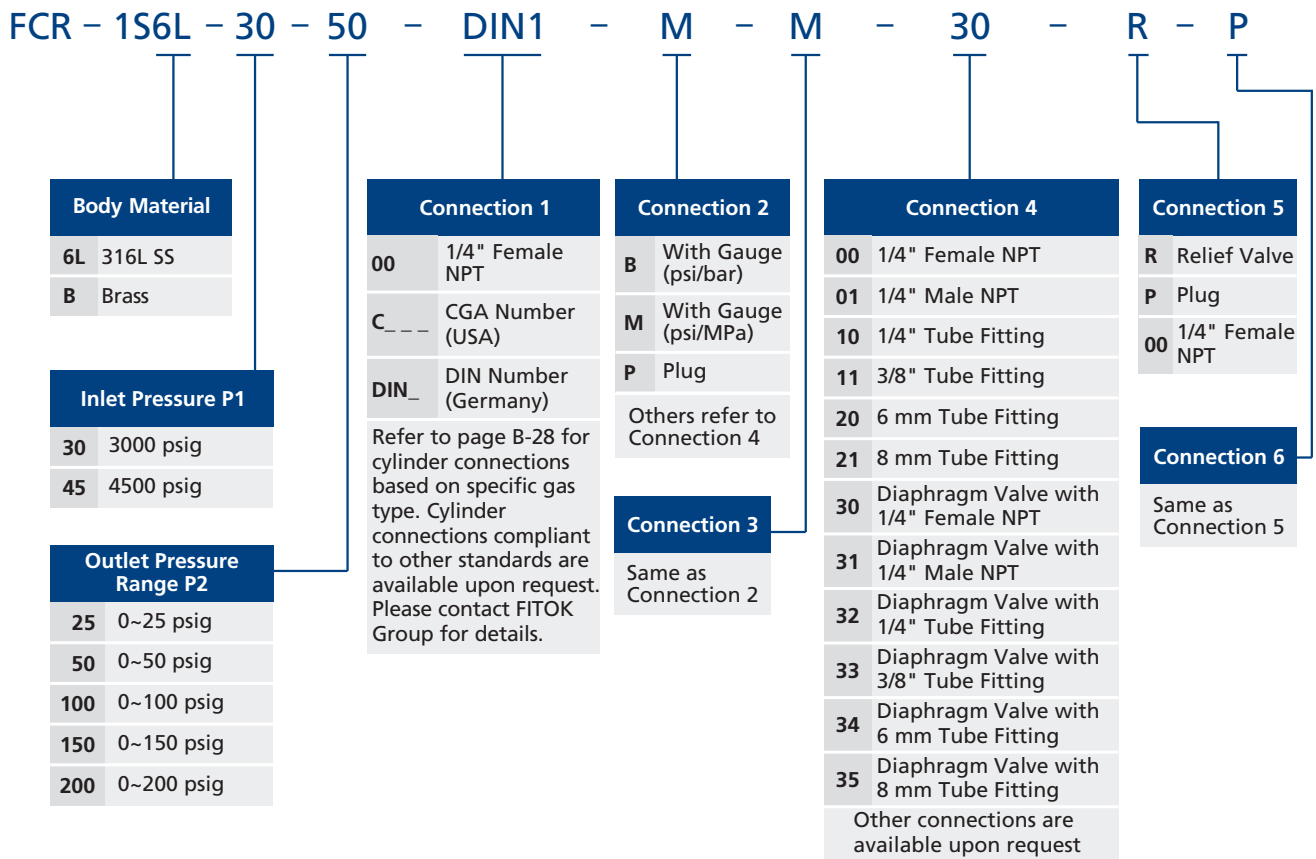

Notes:

1. Most configurations are available.
2. Before ordering, please read **Installation Instructions and Cautions** on A-77.

Examples of part number:

- a. 2-port type (1 in, 1 out): FCR-1S6L-45-25-C580-00
- b. 3-port type (1 in, 2 out): FCR-1SB-30-150-C330-B-00
- c. 4-port type (2 in, 2 out): FCR-1SB-45-200-00-00-00-00

# Cylinder Pressure Regulators

## FCR-2 Series High Pressure Piston Regulators

### Features

- ⦿ For high pressure applications
- ⦿ Robust piston-sensed design to ensure safety and reliability
- ⦿ 316L SS or Nickel-plated Brass body optional
- ⦿ For non-corrosive gases (due to seal limit)
- ⦿ With special cleaning and packaging, applicable to oxygen-enriched environments
- ⦿ Venting model available
- ⦿ 20 µm filter installed at inlet



Model: FCR-26L-45-750-DIN8-B-B-00-P-P

### Technical Data

- ⦿ Single-stage regulator
- ⦿ Maximum inlet pressure: 4500 or 6000 psig
- ⦿ Outlet pressure range: 0~750, 0~1500 or 0~2500 psig
- ⦿ Material of the internal components:
  - Main Seat: PCTFE (PEEK for Venting Model)
  - Vent Seat: PCTFE
  - Piston: 316L
  - O-ring: Viton or Kalrez
  - Filter: 316L
- ⦿ Temperature: -15°F~+165°F (-26°C~+74°C)
- ⦿ Leak rates:
  - Internal: Bubble-tight
  - External: Bubble-tight
- ⦿ Flow coefficient (Cv):
  - Without vent: 0.06
  - Vent: 0.1
- ⦿ Weight (regulator only): ≈ 1.98 lbs (0.9 kg)
- ⦿ Body ports: 1/4" female NPT for inlet, outlet and gauge

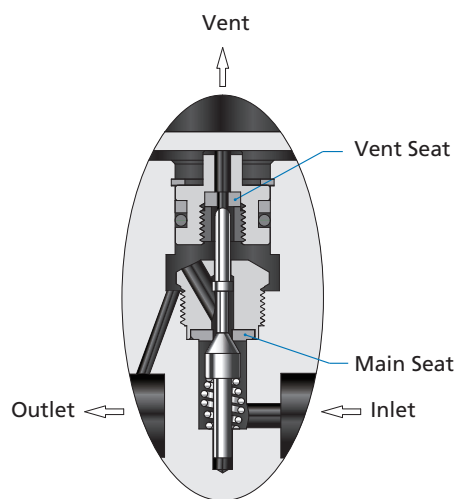

Construction Drawing with Venting Model

### Typical Flow Chart

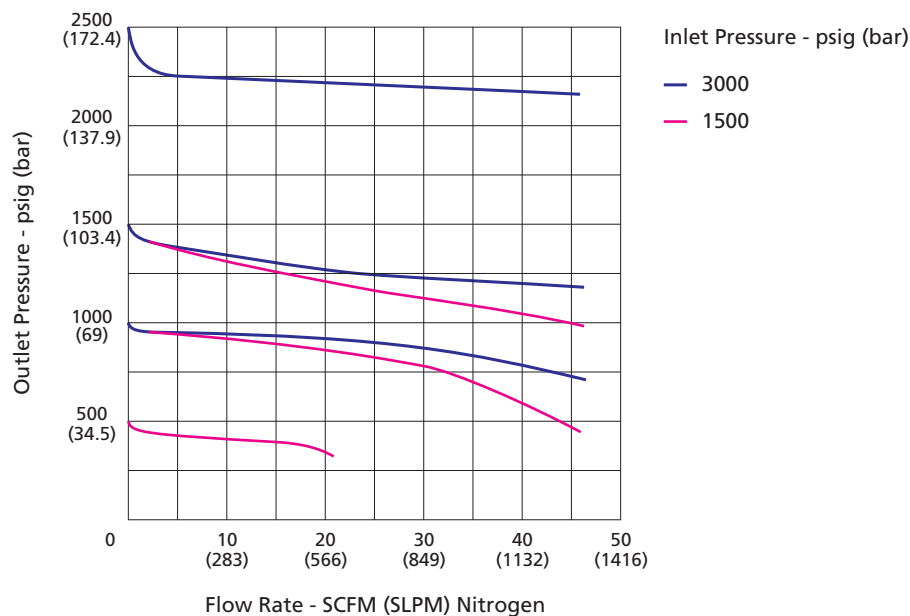

## Dimensions

Dimensions, in inches (millimeters), are for reference only.

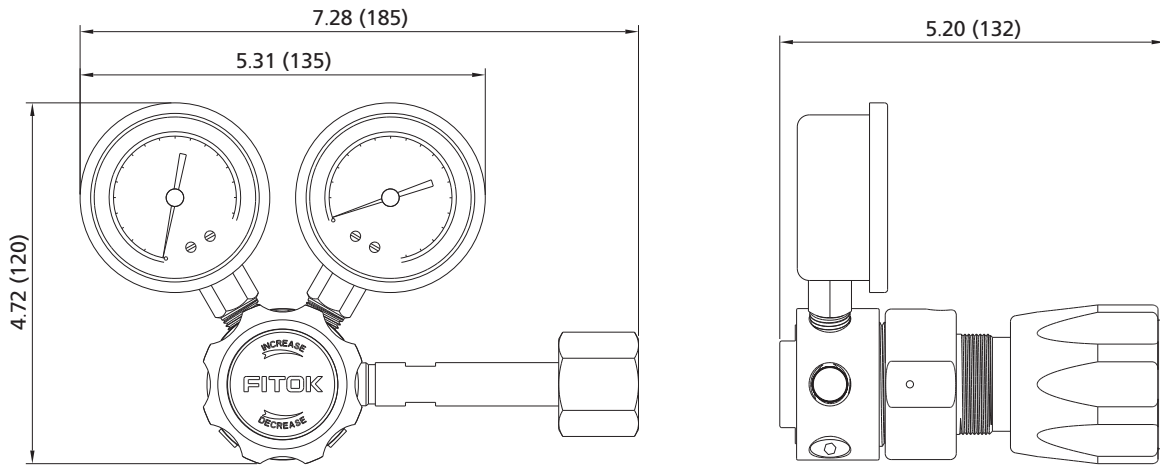

## Port Configurations

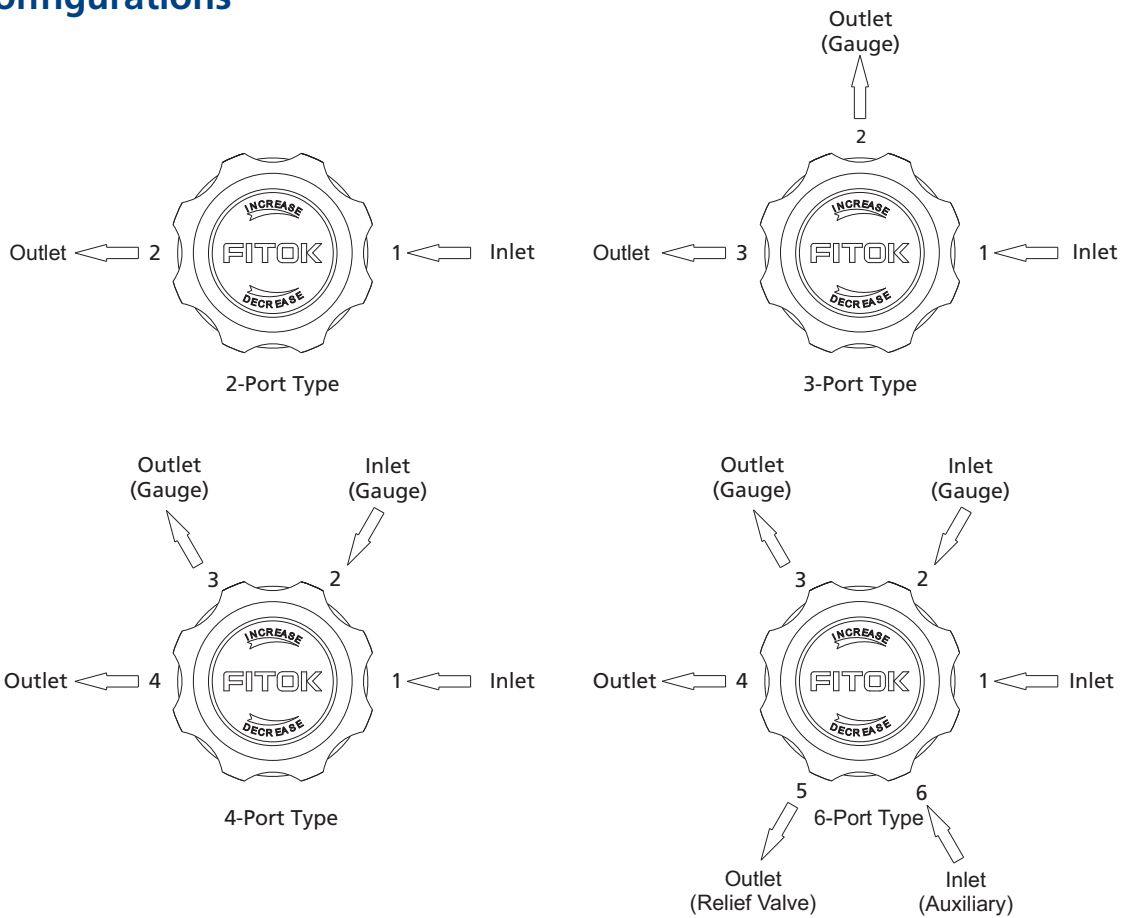

## Part Number Description

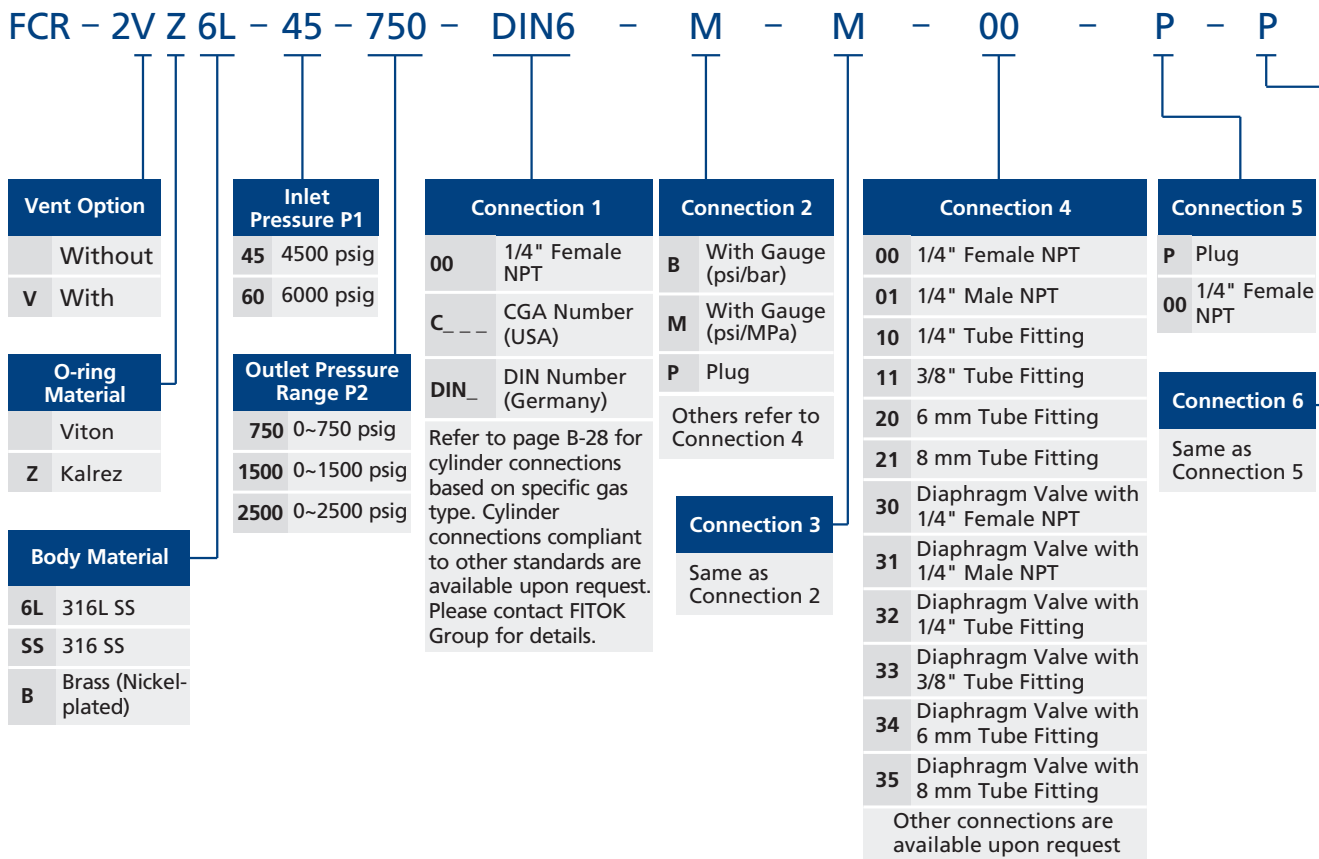

**Notes:**

1. Most configurations are available.
2. Before ordering, please read **Installation Instructions and Cautions** on A-77.

Examples of part number:

- a. 2-port type (1 in, 1 out): FCR-26L-45-1500-C580-00
- b. 3-port type (1 in, 2 out): FCR-2VB-45-750-C660-00-00
- c. 4-port type (2 in, 2 out): FCR-2VZSS-60-2500-00-B-B-32

# Cylinder Pressure Regulators

## FCR-1D Series Dual-stage Diaphragm Regulators

### Features

- ⦿ Compact design
- ⦿ Dual-stage pressure reducing construction to provide accurate and stable pressure
- ⦿ 20  $\mu\text{m}$  filter installed at inlet
- ⦿ With special cleaning and packaging, applicable to oxygen-enriched environments



Model: FCR-1D6L-30-100-C660-B-B-00-R-P

### Technical Data

- ⦿ Maximum inlet pressure: 3000 or 4500 psig
- ⦿ 1st stage outlet pressure range: 480~500 psig  
2nd stage outlet pressure range: 0~25, 0~50, 0~100, 0~150, 0~250 psig
- ⦿ Material of the internal components:  
Seat: PCTFE  
Diaphragm: Hastelloy  
Filter: 316L
- ⦿ Temperature:  $-40^{\circ}\text{F} \sim +165^{\circ}\text{F}$  ( $-40^{\circ}\text{C} \sim +74^{\circ}\text{C}$ )
- ⦿ Leak rates:  
Internal:  $\leq 1 \times 10^{-7}$  mbar·l/s helium  
External:  $\leq 1 \times 10^{-9}$  mbar·l/s helium
- ⦿ Flow coefficient (Cv): 0.05
- ⦿ Weight (regulator only):  $\approx 3.3$  lbs (1.5 kg)
- ⦿ Body ports: 1/4" female NPT for inlet, outlet, gauge and relief valve

### Typical Flow Chart

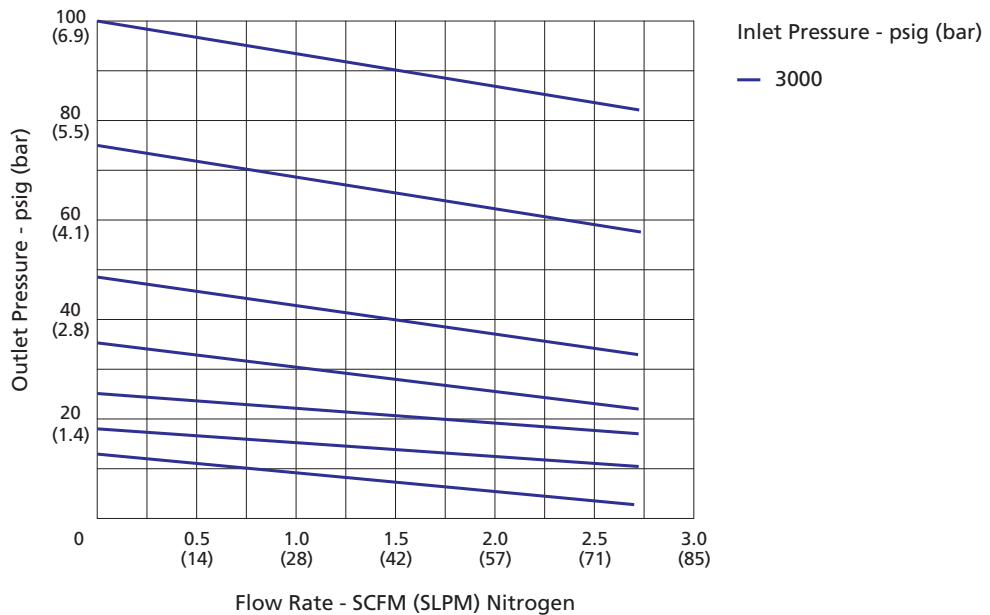

## Dimensions

Dimensions, in inches (millimeters), are for reference only.

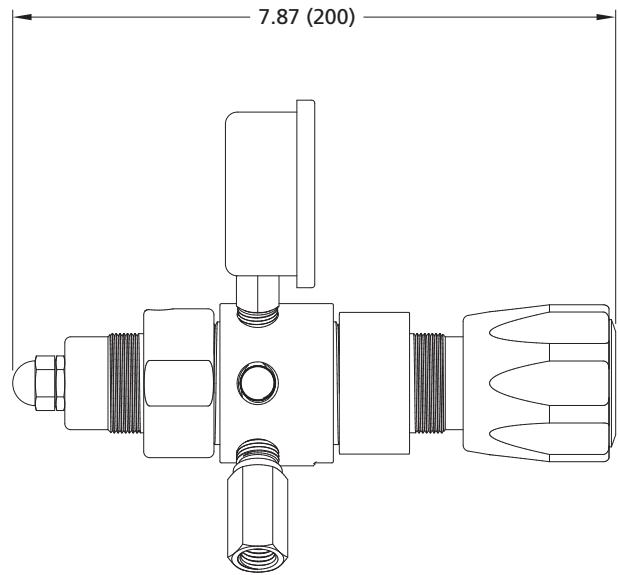
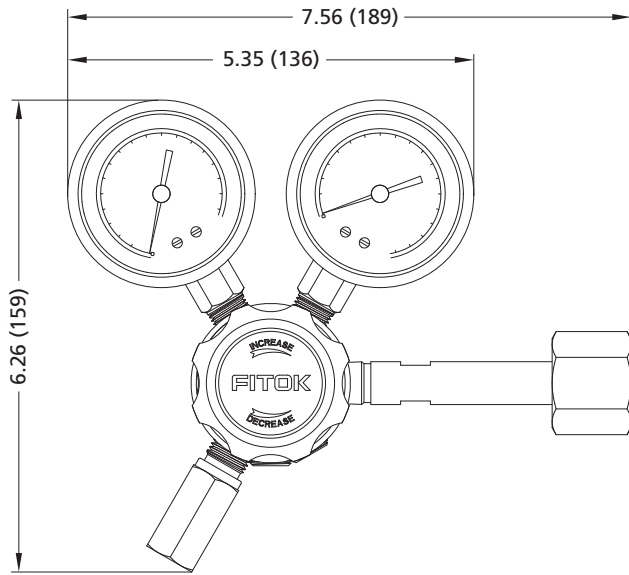

## Port Configurations

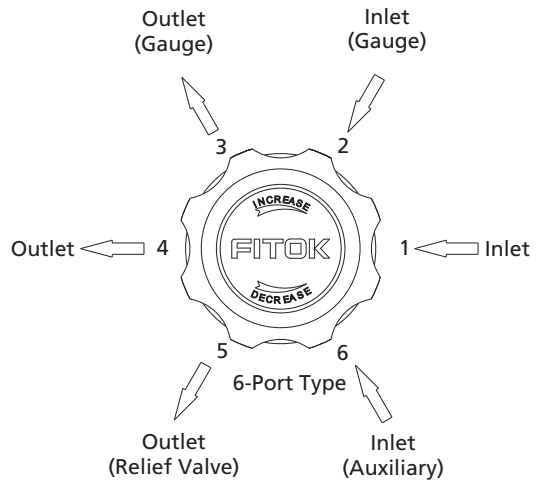
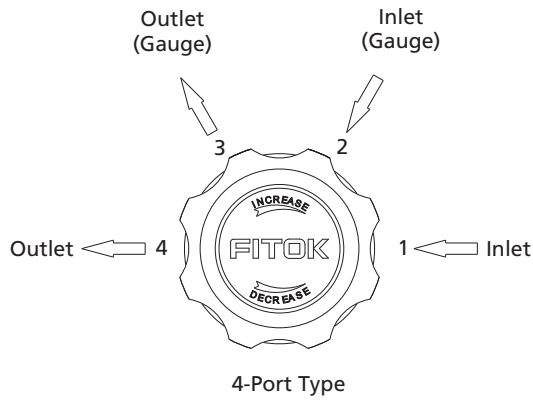



## Part Number Description

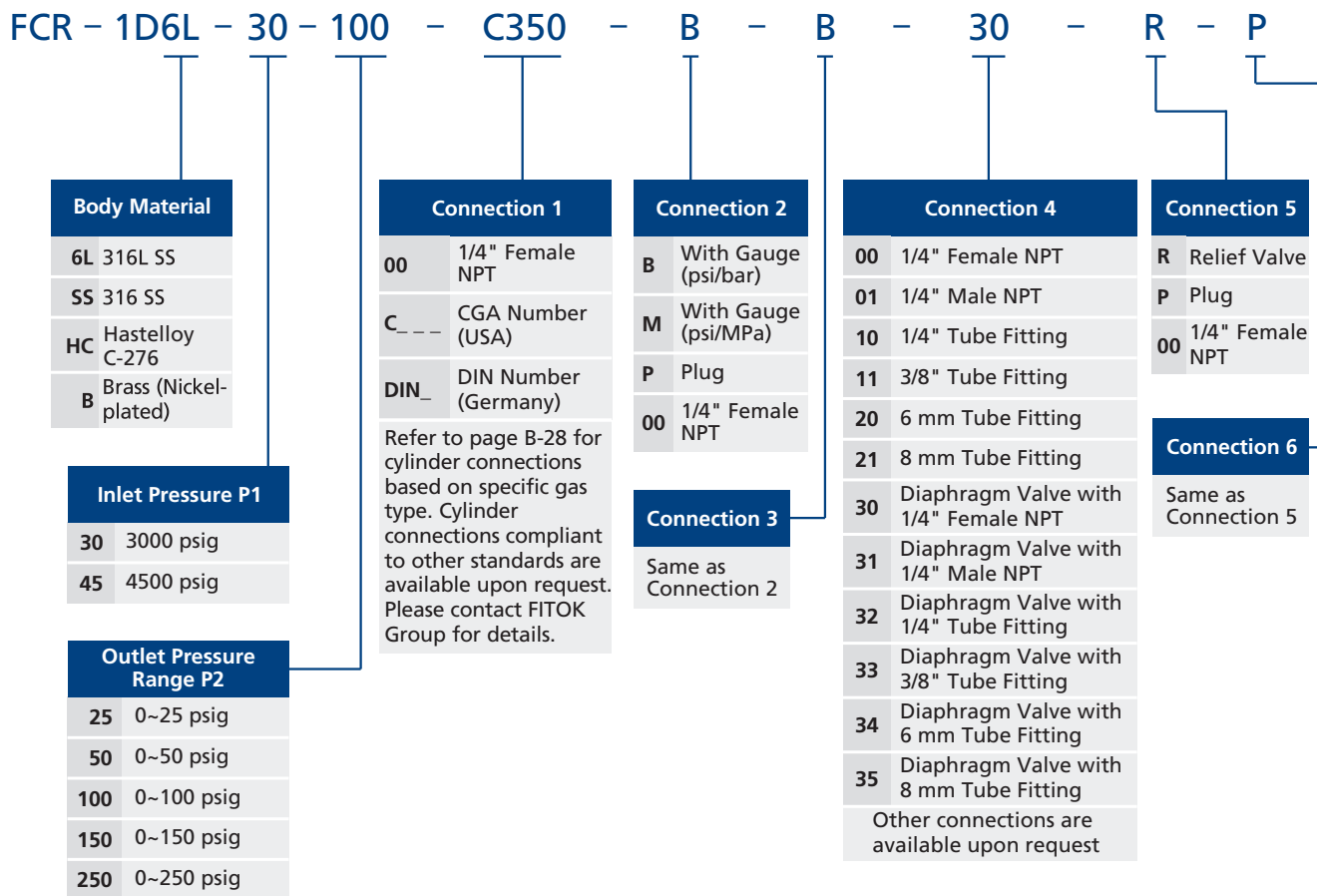

Notes:

1. Most configurations are available.
2. Before ordering, please read **Installation Instructions and Cautions** on A-77.

Examples of part number:

- a. 4-port type (2 in, 2 out): FCR-1DB-45-150-DIN1-B-B-30
- b. 6-port type (3 in, 3 out): FCR-1DSS-30-50-C580-B-B-00-R-P

# Line Pressure Regulators

## FLR-1 Series Compact Diaphragm Regulators

### Features

- Similar to FCR-1 Series Regulators with larger orifice to provide higher flow capacity
- Three port configurations available
- 316L SS body for corrosive or toxic gases, Nickel-plated Brass body for non-corrosive gases
- With special cleaning and packaging, applicable to oxygen-enriched environments
- Configuration with filter installed at inlet as standard
- Panel mounted or installed with screw at the bottom



Model: FLR-16L-15-100-00-00-Z

### Technical Data

- Single-stage regulator
- Maximum inlet pressure: 500 or 1500 psig
- Outlet pressure range: 0~25, 0~50, 0~100 or 0~250 psig
- Material of the internal components:
  - Seat: PCTFE
  - Diaphragm: Hastelloy
  - Filter: 316L
- Temperature: -40°F~+165°F (-40°C~+74°C)
- Leak rates:
  - Internal:  $\leq 1 \times 10^{-7}$  mbar·l/s helium
  - External:  $\leq 1 \times 10^{-9}$  mbar·l/s helium
- Flow coefficient (Cv): 0.14
- Weight (regulator only):  $\approx 1.98$  lbs (0.9 kg)
- Body ports: 1/4" female NPT for inlet, outlet and gauge

### Typical Flow Chart

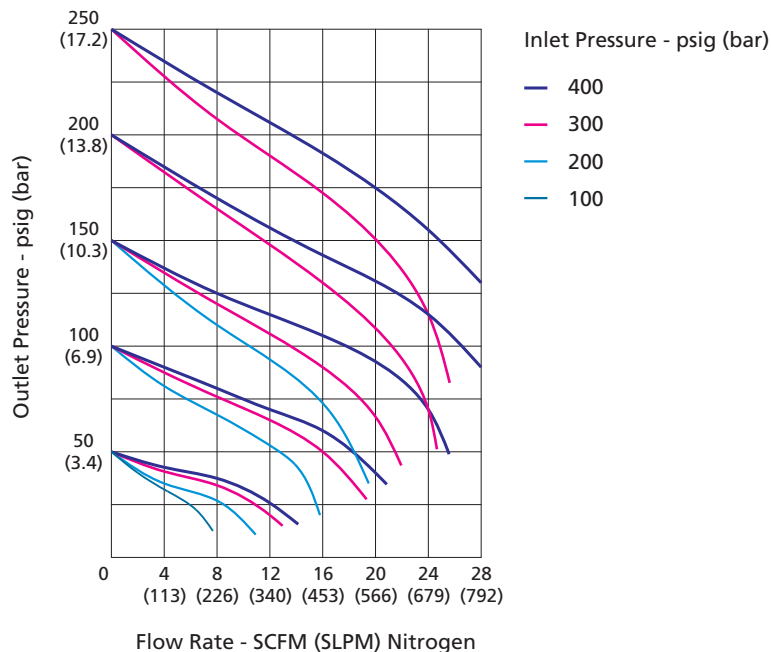

## Dimensions

Dimensions, in inches (millimeters), are for reference only.

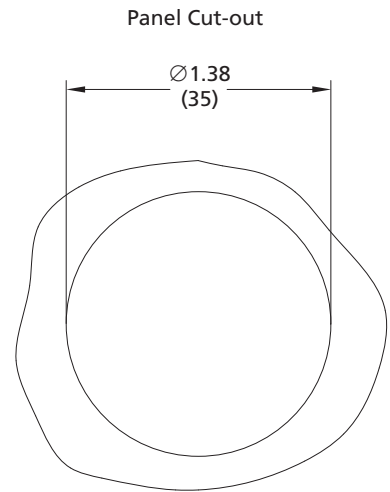
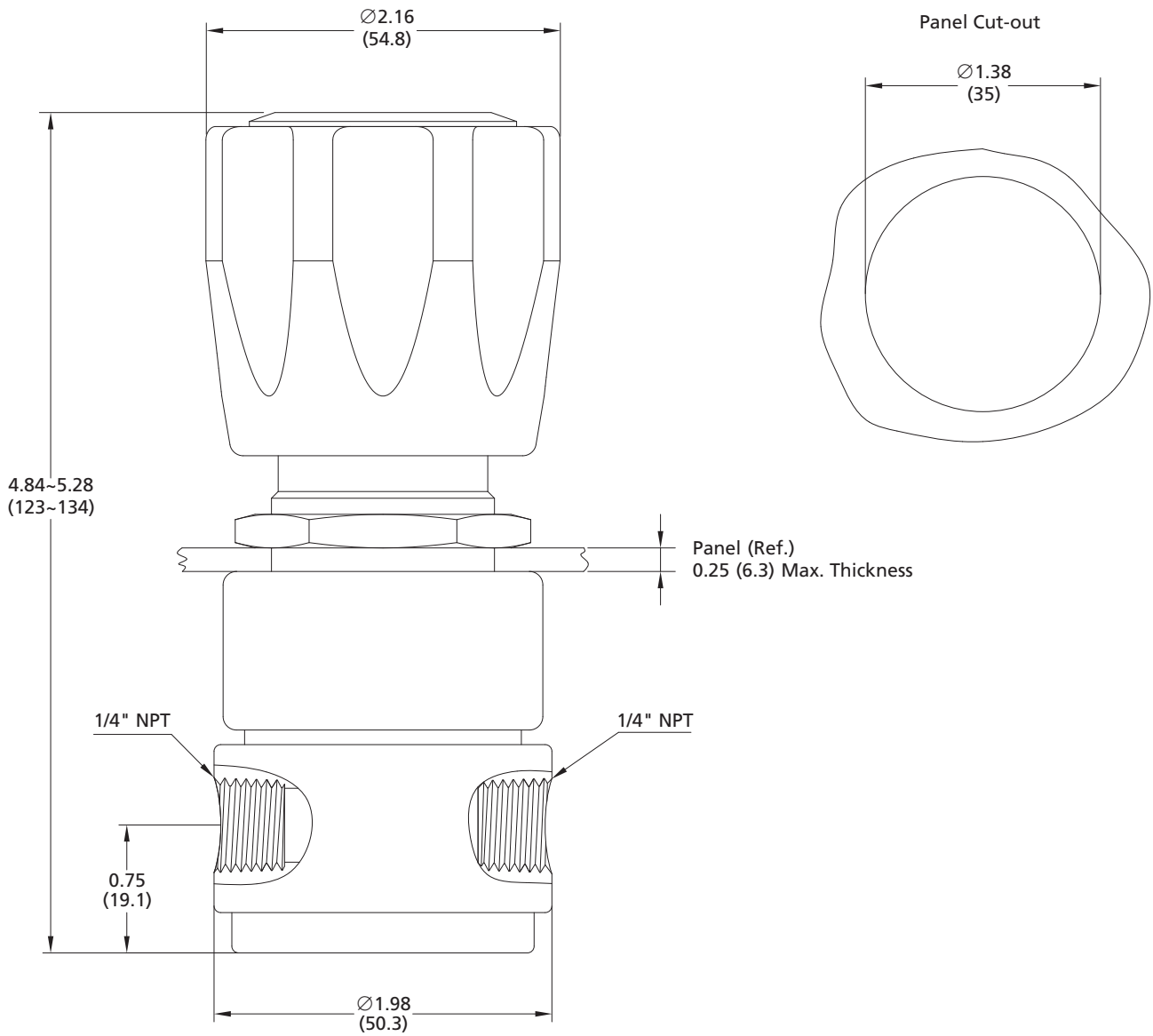

Bottom Panel Cut-outs

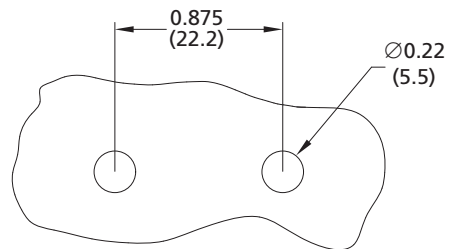
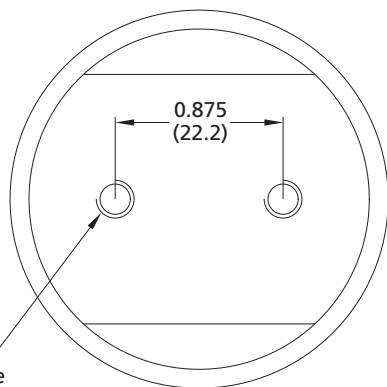

2xM5x0.8-6H thread  
The holes are compatible  
with 10-32 mounting screws

## Port Configurations

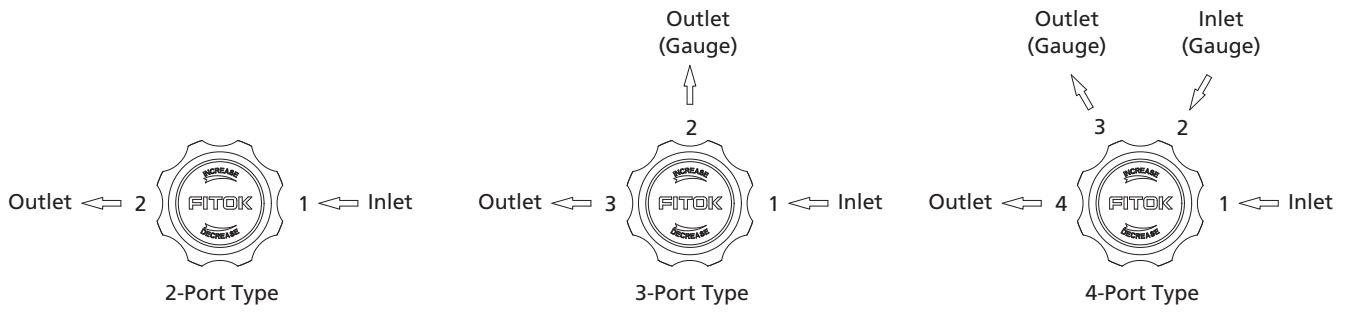

## Part Number Description

FLR - 16L - 15 - 100 - 00 - B - B - 00 - Z

Body Material	Inlet Pressure P1	Connection 1	Connection 2	Connection 3	Connection 4	Installation Type
6L 316L SS	05 500 psig	00 1/4" Female NPT	B With Gauge (psi/bar)	Same as Connection 2	Same as Connection 1	Not Required
SS 316 SS	15 1500 psig	01 1/4" Male NPT	M With Gauge (psi/MPa)			Z Installed with One Panel Nut
HC Hastelloy C-276		10 1/4" Tube Fitting	P Plug			N Installed with Screws at the Bottom
B Brass (Nickel-plated)		11 3/8" Tube Fitting	00 1/4" Female NPT			
		20 6 mm Tube Fitting	01 1/4" Male NPT			
		21 8 mm Tube Fitting	10 1/4" Tube Fitting			
		Other connections are available upon request	11 3/8" Tube Fitting			
			20 6 mm Tube Fitting			
			21 8 mm Tube Fitting			
			Other connections are available upon request			

**Notes:**

- 1. Most configurations are available.
- 2. Before ordering, please read **Installation Instructions and Cautions** on A-77.

Examples of part number:

- a. 2-port type (1 in, 1 out): FLR-16L-15-25-00-00
- b. 3-port type (1 in, 2 out): FLR-16L-05-100-00-B-00

# Line Pressure Regulators

## FLR-2 Series Piston Regulators

### Features

- ⦿ Applicable to non-corrosive gases or low-viscosity liquids
- ⦿ Easy to assemble and disassemble, convenient replacement of springs with different output ranges
- ⦿ Robust piston-sensed design to provide safety and reliability
- ⦿ With special cleaning and packaging, applicable to oxygen-enriched environments
- ⦿ Three port configurations available
- ⦿ Panel mounted or installed with screws at the bottom

### Technical Data

- ⦿ Single-stage regulator
- ⦿ Maximum inlet pressure: 3000 or 4500 psig
- ⦿ Outlet pressure range: 0~250, 0~500, 0~750 or 0~1000 psig
- ⦿ Material of the internal components:
  - Main Seat: PCTFE (PEEK for Venting Model)
  - Vent Seat: PCTFE
  - Piston: 316L
  - O-ring: Viton or Kalrez
  - Filter: 316L
- ⦿ Temperature: -15°F~+165°F (-26°C~+74°C)
- ⦿ Leak rates:
  - Internal: Bubble-tight
  - External: Bubble-tight
- ⦿ Flow coefficient (Cv):
  - Without vent: 0.06
  - Vent: 0.1
- ⦿ Weight (regulator only): ≈1.98 lbs (0.9 kg)
- ⦿ Body ports: 1/4" female NPT for inlet, outlet and gauge



Model: FLR-2SS-45-1000-00-00-Z

### Typical Flow Chart

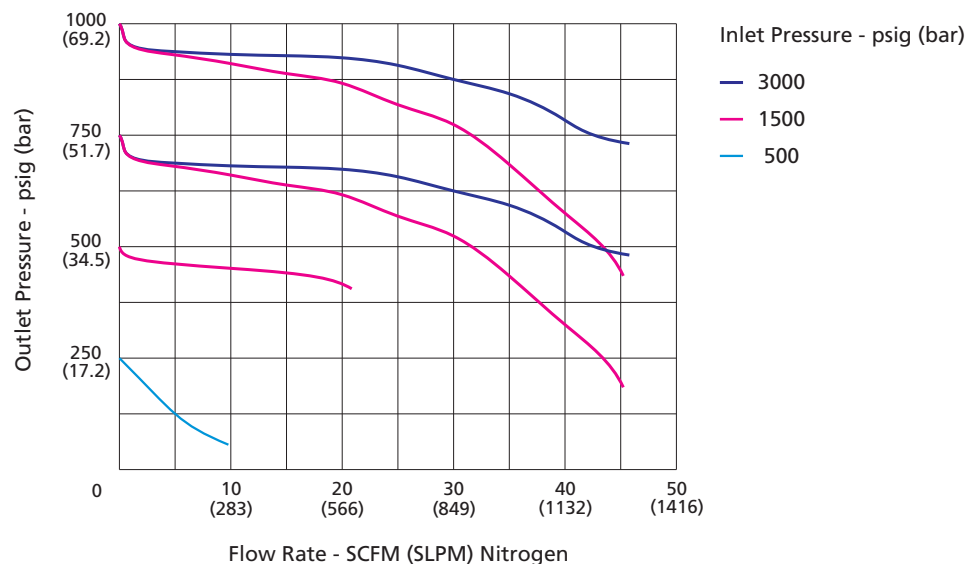

## Dimensions

Dimensions, in inches (millimeters), are for reference only.

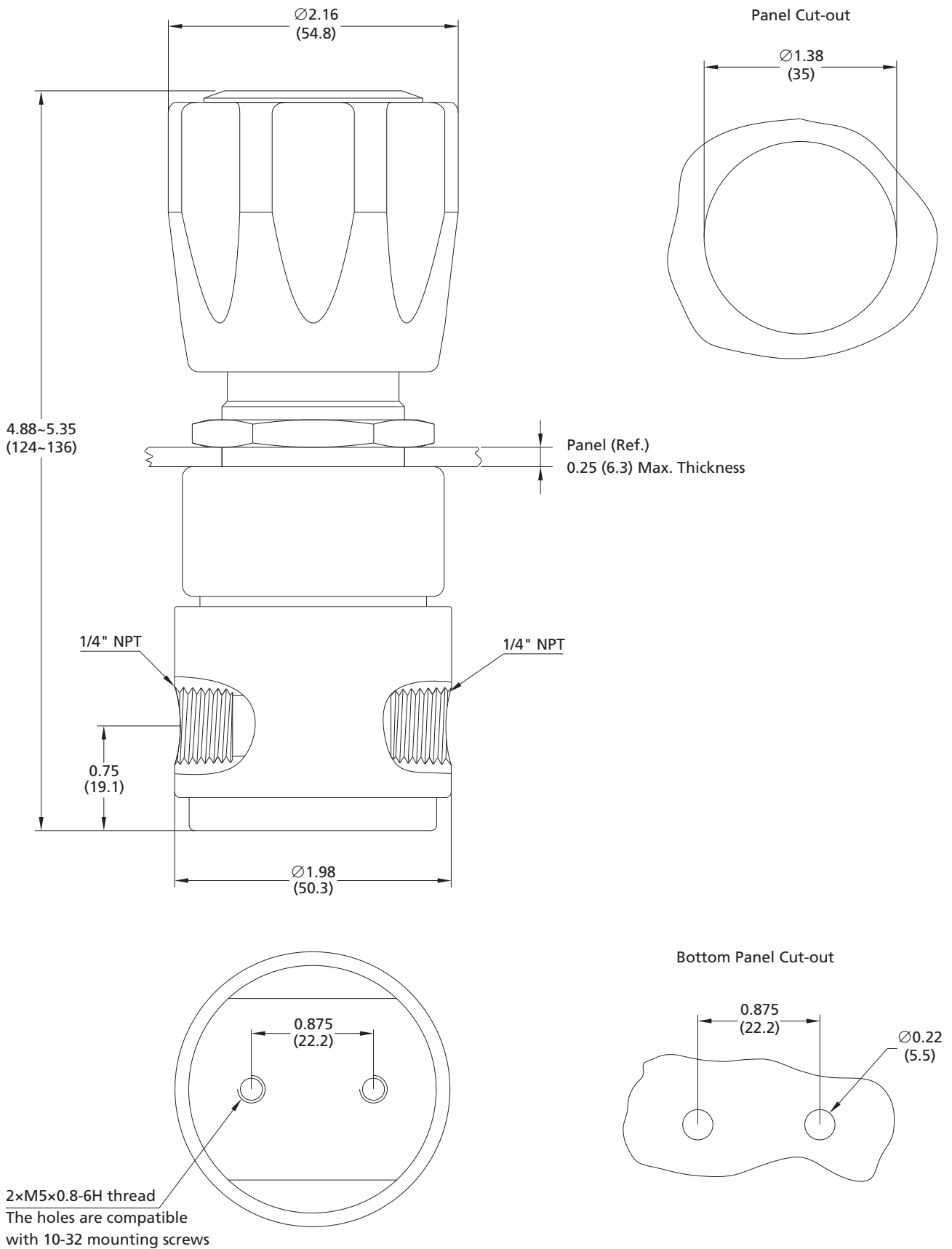

## Port Configurations

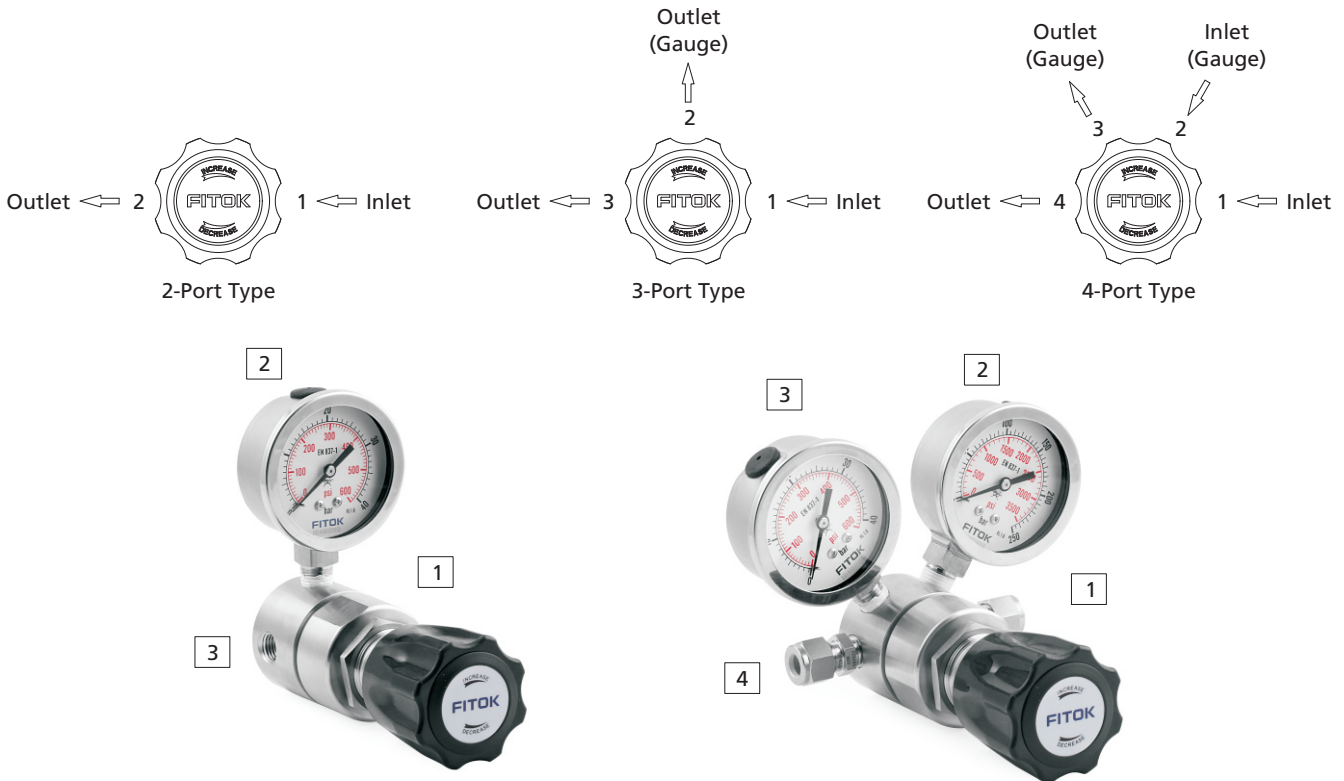

## Part Number Description

FLR - 2V Z 6L - 45 - 500 - 10 - B - B - 10 - Z

Vent Option	Inlet Pressure P1	Connection 1	Connection 2	Connection 3	Connection 4
Without	30 3000 psig	00 1/4" Female NPT	B With Gauge (psi/bar)	Same as Connection 2	Same as Connection 1
V With	45 4500 psig	01 1/4" Male NPT	M With Gauge (psi/MPa)		
O-ring Material	Outlet Pressure Range P2	10 1/4" Tube Fitting	P Plug	Installation Type	
Viton	250 0~250 psig	11 3/8" Tube Fitting	00 1/4" Female NPT	Not Required	
Z Kalrez	500 0~500 psig	20 6 mm Tube Fitting	01 1/4" Male NPT	Z Installed with One Panel Nut	
Body Material	750 0~750 psig	21 8 mm Tube Fitting	10 1/4" Tube Fitting	N Installed with Screws at the Bottom	
6L 316L SS	1000 0~1000 psig	Other connections are available upon request	11 3/8" Tube Fitting		
SS 316 SS			20 6 mm Tube Fitting		
B Brass (Nickel-plated)			21 8 mm Tube Fitting		
			Other connections are available upon request		

Notes:  
 1. Most configurations are available.  
 2. Before ordering, please read **Installation Instructions and Cautions** on A-77.

- Examples of part number:  
 a. 2-port type (1 in, 1 out): FLR-26L-30-250-00-00  
 b. 3-port type (1 in, 2 out): ,FLR-25S-45-1000-00-00-00

# Line Pressure Regulators

## FLR-3 Series Medium Flow Diaphragm Regulators

### Features

- ⦿ For high inlet pressure applications
- ⦿ Balanced poppet
- ⦿ With large orifice to minimize outlet pressure change when inlet pressure reduces
- ⦿ Large diameter convoluted diaphragm to increase pressure sensitivity
- ⦿ 316L SS body for corrosive or toxic gases, Brass body for non-corrosive gases
- ⦿ With special cleaning and packaging, applicable to oxygen-enriched environments
- ⦿ Three port configurations available
- ⦿ Panel mounted or installed with screws at the bottom
- ⦿ Fitted with captured vent as standard

### Technical Data

- ⦿ Single-stage regulator
- ⦿ Maximum inlet pressure: 500 or 3000 psig
- ⦿ Outlet pressure range: 0~25, 0~50, 0~100, 0~150 or 0~200 psig
- ⦿ Material of the internal components:
  - Seat: PCTFE
  - Diaphragm: Hastelloy
- ⦿ Temperature: -40°F~+140°F (-40°C~+60°C)
- ⦿ Leak rates:
  - Internal: Bubble-tight
  - External:  $\leq 1 \times 10^{-9}$  mbar·l/s helium
- ⦿ Flow coefficient (Cv): 1.0
- ⦿ Weight (regulator only):  $\approx 3.53$  lbs (1.6 kg)
- ⦿ Body ports: 1/2" female NPT for inlet, outlet  
1/4" female NPT for gauge



Model: FLR-3SS-30-100-04-04-Z

### Typical Flow Chart

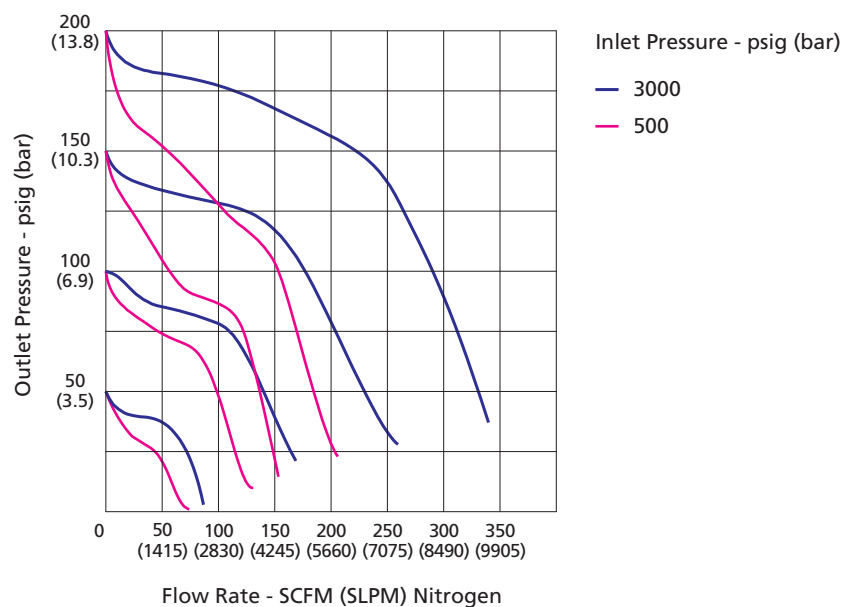



## Dimensions

Dimensions, in inches (millimeters), are for reference only.

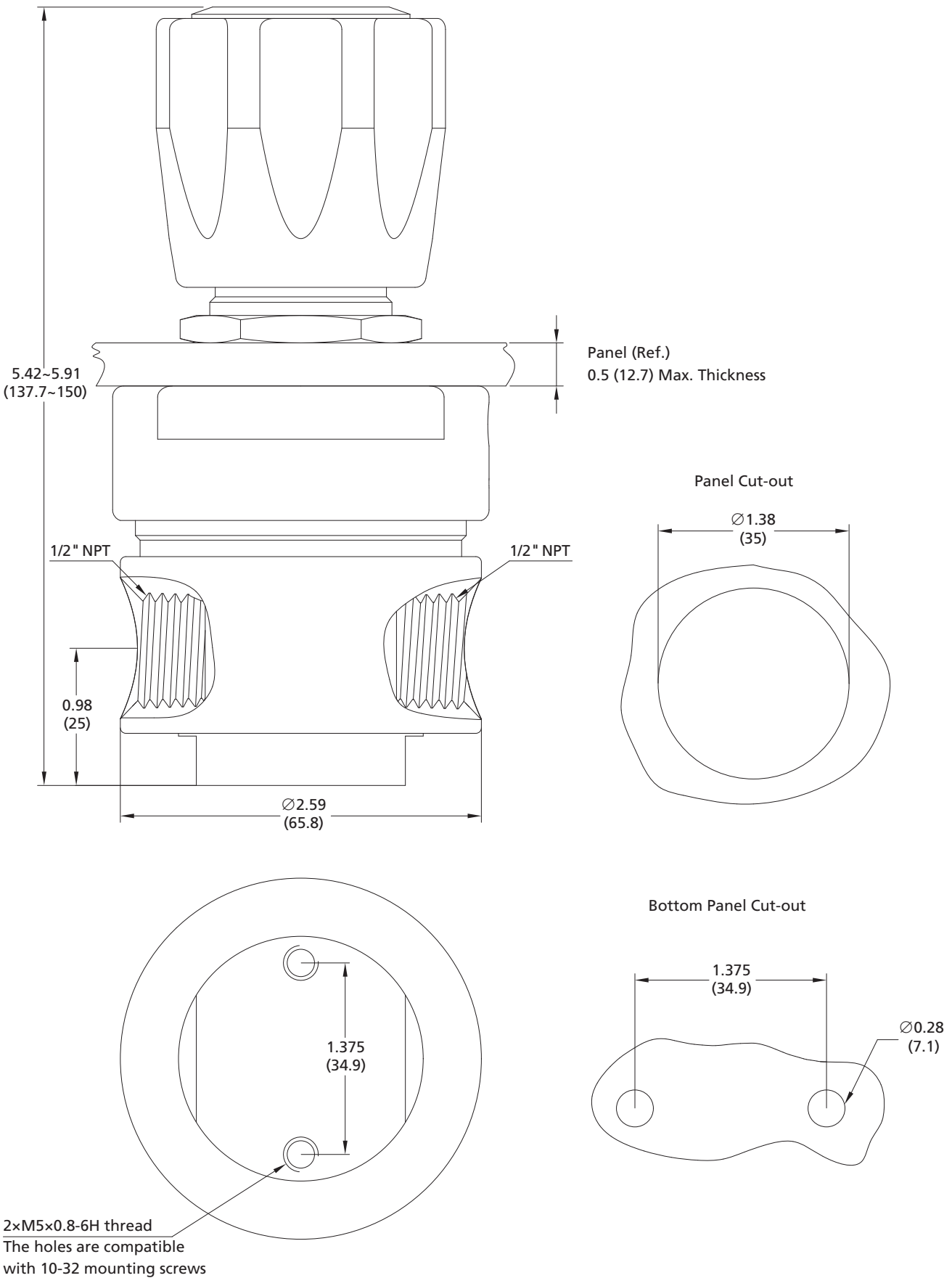

# Port Configurations

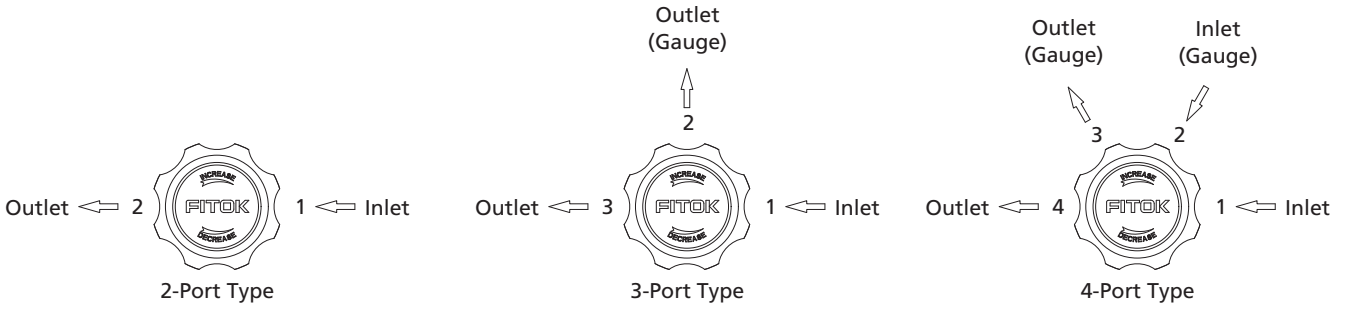

## Part Number Description

FLR - 3B - 30 - 100 - 04 - B - B - 04 - Z

Body Material		Inlet Pressure P1		Connection 1		Connection 2		Connection 3		Connection 4	
6L	316L SS	05	500 psig	04	1/2" Female NPT	B	With Gauge (psi/bar)	3 Ports Same as Connection 1		Same as Connection 1	
SS	316 SS	30	3000 psig	11	3/8" Tube Fitting	M	With Gauge (psi/MPa)	4 Ports Same as Connection 2			
B	Brass			12	1/2" Tube Fitting	P	Plug				
				22	10 mm Tube Fitting	00	1/4" Female NPT				
				23	12 mm Tube Fitting	01	1/4" Male NPT				
				Other connections are available upon request		10	1/4" Tube Fitting				
						11	3/8" Tube Fitting				
						20	6 mm Tube Fitting				
						21	8 mm Tube Fitting				
						Other connections are available upon request					
										Installation Type	
										Not Required	
										Z Installed with One Panel Nut	
										M Installed with Two Panel Nuts	
										N Installed with Screws at the Bottom	

Notes:  
 1. Most configurations are available.  
 2. Before ordering, please read **Installation Instructions and Cautions** on A-77.  
 Examples of part number:  
 a. 2-port type (1 in, 1 out): FLR-36L-30-150-04-04  
 b. 3-port type (1 in, 2 out): FLR-3SS-05-200-04-00-04

# Line Pressure Regulators

## FLR-5 Series High Flow Diaphragm Regulators

### Features

- ⦿ Suitable for low pressure and high flow applications
- ⦿ Large diameter convoluted diaphragm to increase pressure sensitivity
- ⦿ 316L SS body for corrosive gases, and Brass body for non-corrosive gases
- ⦿ Fitted with captured vent as standard
- ⦿ With special cleaning and packaging, applicable to oxygen-enriched environments
- ⦿ Panel mounted or installed with screws at the bottom

### Technical Data

- ⦿ Single-stage regulator
- ⦿ Maximum inlet pressure: 500 psig
- ⦿ Outlet pressure ranges: 0~15, 0~30, 0~75, 0~150 psig
- ⦿ Material of the internal components:
  - Seat: PCTFE
  - Diaphragm: Hastelloy
- ⦿ Temperature: -40°F~+165°F (-40°C~+74°C)
- ⦿ Leak rates:
  - Internal: Bubble-tight
  - External:  $\leq 1 \times 10^{-9}$  mbar.l/s helium
- ⦿ Flow coefficient (Cv): 1.8
- ⦿ Weight (regulator only):  $\approx 5.95$  lbs (2.7 Kg)
- ⦿ Body ports: 3/4" female NPT for inlet, outlet, 1/4" female NPT for gauge



Model: FLR-56L-05-100-04-04-Z

Gas Control Equipment

Related Products

Technical References

### Typical Flow Chart

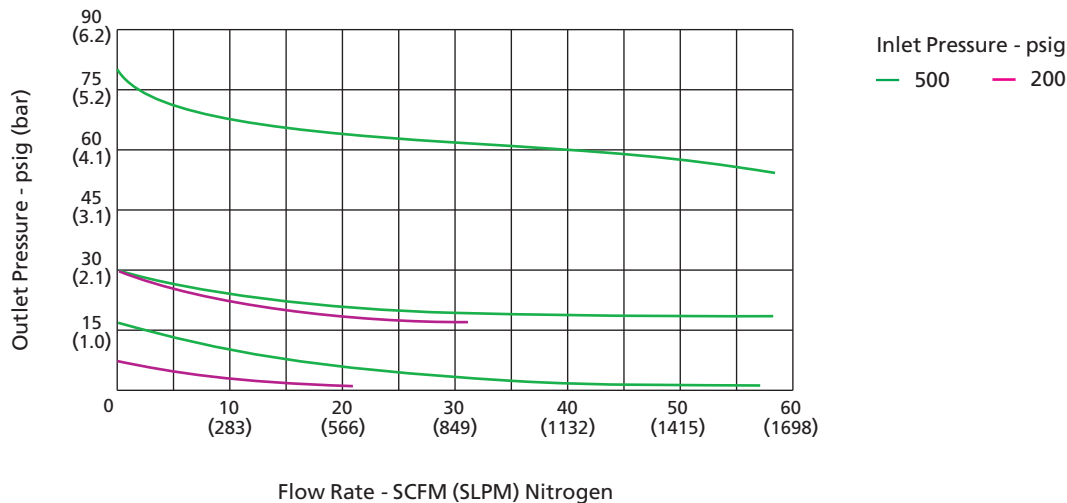



## Port Configurations

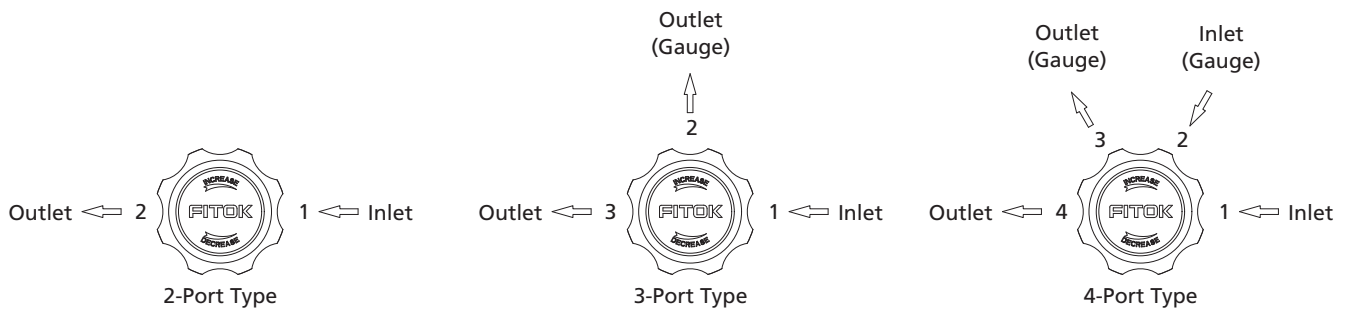

## Part Number Description

FLR - 56L - 05 - 150 - 05 - B - B - 05 - Z

Body Material	
6L	316L SS
SS	316 SS
B	Brass

Inlet Pressure P1	
05	500 psig

Outlet Pressure Range P2	
15	0~15 psig
30	0~30 psig
75	0~75 psig
150	0~150 psig

Connection 1	
05	3/4" Female NPT
14	3/4" Tube Fitting
16	1" Tube Fitting
25	16 mm Tube Fitting
26	18 mm Tube Fitting
27	20 mm Tube Fitting
28	22 mm Tube Fitting
Other connections are available upon request	

Connection 2	
B	With Gauge (psi/bar)
M	With Gauge (psi/MPa)
P	Plug
00	1/4" Female NPT
01	1/4" Male NPT
10	1/4" Tube Fitting
11	3/8" Tube Fitting
20	6 mm Tube Fitting
21	8 mm Tube Fitting
Other connections are available upon request	

Connection 3	
Same as Connection 2	

Connection 4	
Same as Connection 1	

Installation Type	
Not Required	
Z	Installed with One Panel Nut
M	Installed with Two Panel Nuts
N	Installed with Screws at the Bottom

**Notes:**

- Most configurations are available.
- Before ordering, please read **Installation Instructions and Cautions** on A-77.

Examples of part number:

- 2-port type (1 in, 1 out): FLR-56L-05-150-05
- 3-port type (1 in, 2 out): FLR-56L-05-30-05-B-05
- 4-port type (2 in, 2 out): FLR-5SS-05-150-05-B-B-05

# Line Pressure Regulators

## FBR-1 Series Miniature Piston Regulators

### Features

- ⦿ Applicable to non-corrosive gases or low-viscosity liquids
- ⦿ Easy to assemble and disassemble, convenient replacement of springs with different output ranges
- ⦿ Robust piston-sensed design to provide safety and reliability
- ⦿ With special cleaning and packaging, applicable to oxygen-enriched environments



Model: FBR-15S-60-220-00-00-00

### Technical Data

- ⦿ Media contact materials
  - Body: 316, 316L or Brass (Nickel-plated)
  - Seat: PCTFE, PEEK or Vespel
  - Piston: Aluminium Alloy
  - O-ring: Viton, Kalrez or Buna-N
  - Filter: 316L
- ⦿ Operating conditions
  - Maximum rated inlet pressure: 6000 psig
  - Outlet pressure ranges: 0~80, 0~140, 0~220, 0~700, 0~1200, 0~1800 psig
  - Temperature: -15°F~+165°F (-26°C~+74°C)
- ⦿ Functional performance
  - Test pressure: 150% of maximum rated pressure
  - Burst pressure: 300% of maximum rated pressure
  - Leak rates:
    - Internal: Bubble-tight
    - External: Bubble-tight
- ⦿ Flow coefficient (Cv): 0.06
- ⦿ Weight(regulator only): 0.93 lbs (0.4 kg)
- ⦿ Body ports: 1/4" female NPT for inlet and outlet

### Typical Flow Chart

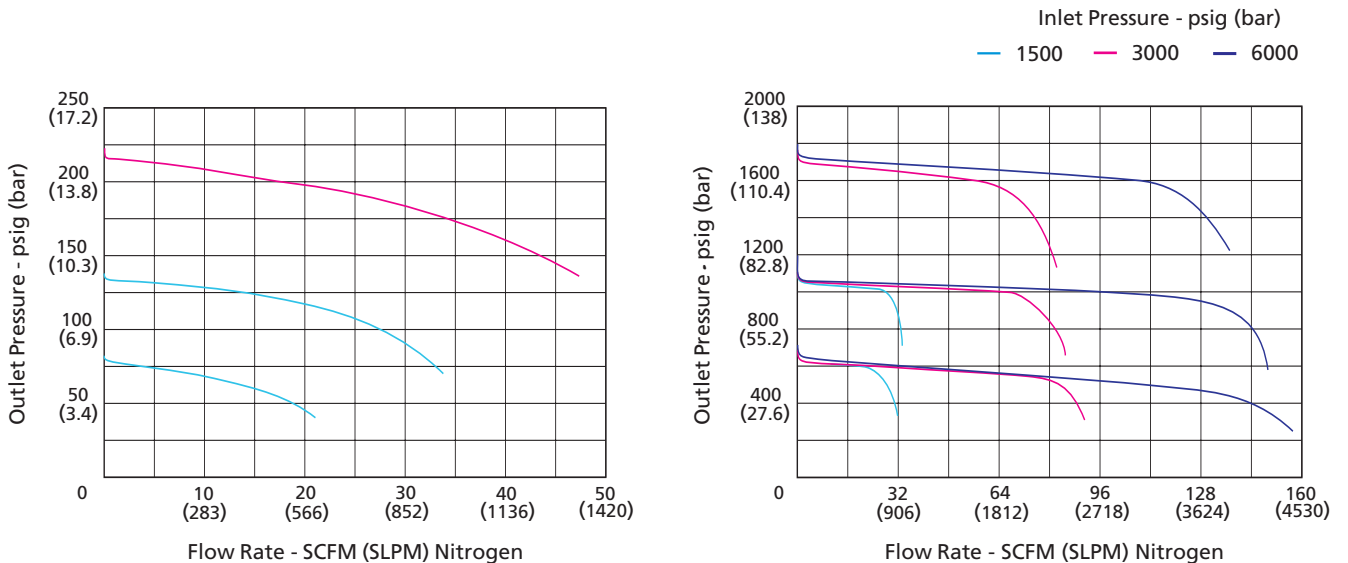

## Dimensions

Dimensions, in inches (millimeters), are for reference only.

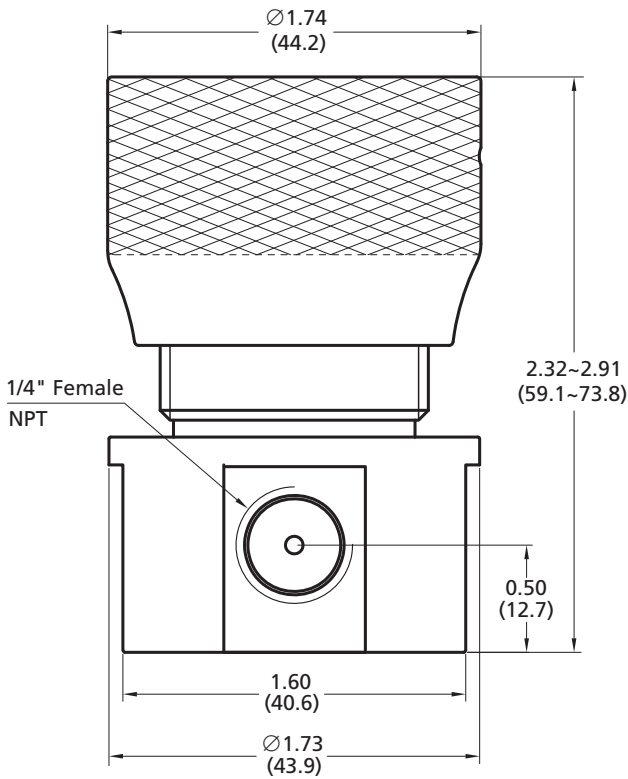

Bottom Panel Cut-outs

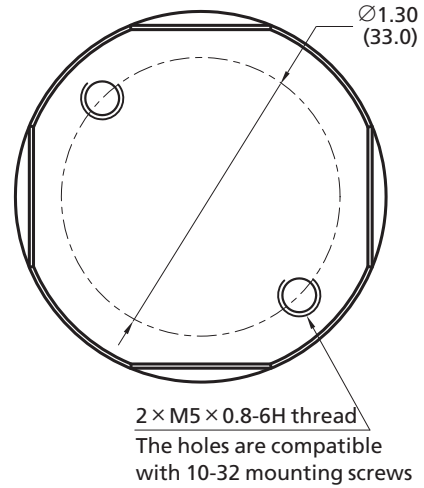

## Port Configurations

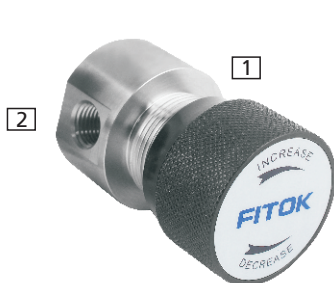
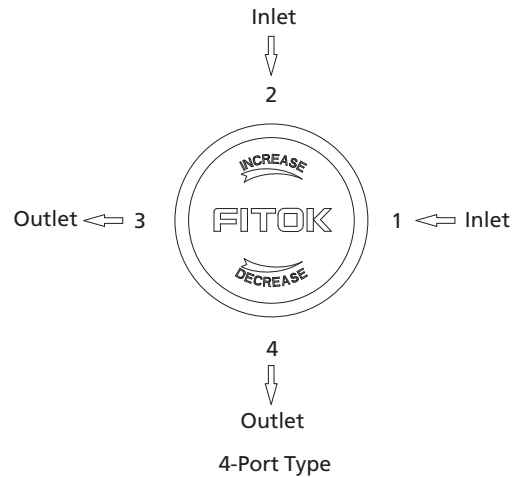
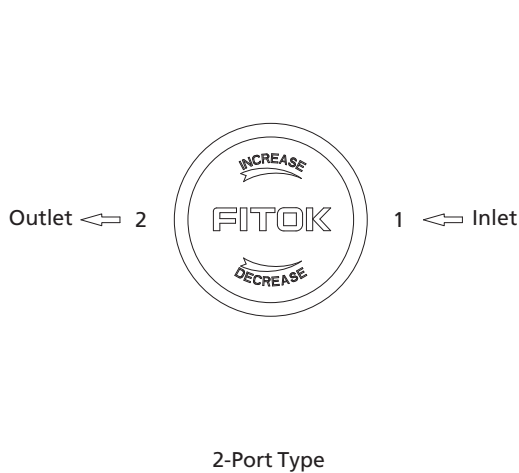

## Part Number Description

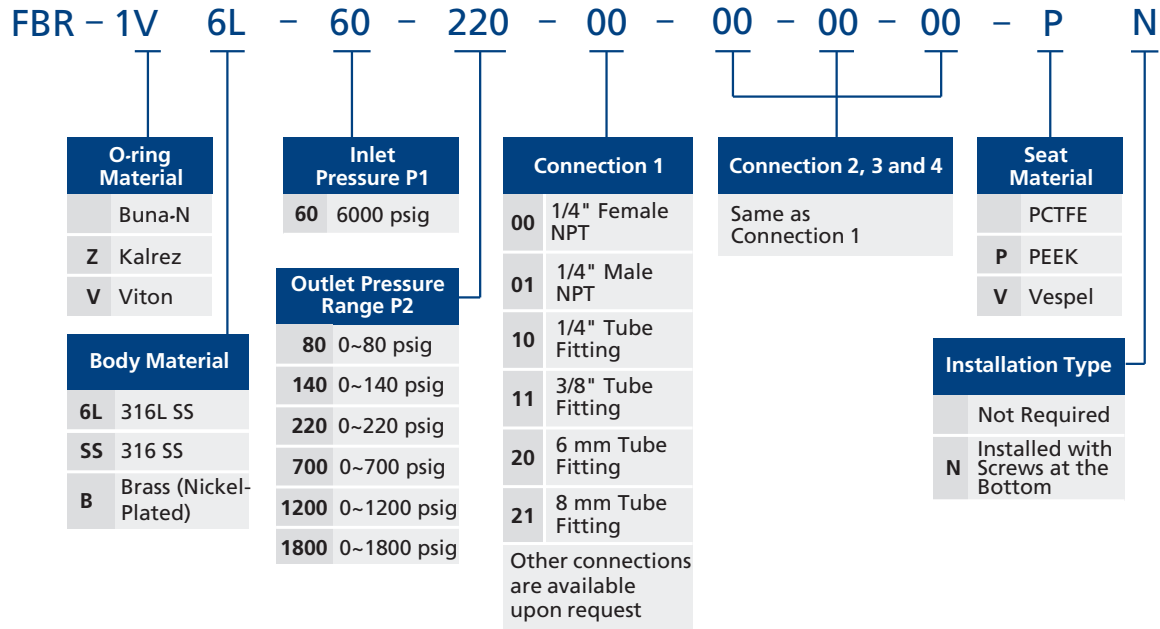

Notes:

1. Most configurations are available.
2. Before ordering, please read **Installation Instructions and Cautions** on A-77.

Examples of part number:

- a. 2-port type (1 in, 1 out): FBR-16L-60-80-00-00
- b. 4-port type (2 in, 2 out): FBR-16L-60-80-00-00-00



# High Pressure Regulators

## HPR-10 Series High Pressure Piston Regulators

### Features

- ⦿ 316 Stainless steel or brass body optional
- ⦿ Robust piston sensed design
- ⦿ Stable outlet pressure and easy tune
- ⦿ 7 different outlet pressure ranges
- ⦿ All pressure ranges can be vented to 0 psig
- ⦿ Applicable to general gases or liquid
- ⦿ Panel mountable

### Technical Data

- ⦿ Maximum inlet pressure:  
Stainless: 10000 psig  
Brass: 6000 psig
- ⦿ Outlet pressure range: 10~500, 15~800, 15~1500, 30~2500, 50~4000, 60~6000 or 200~10000 psig
- ⦿ Materials of the internal components:  
Seat: PEEK  
Piston: 316L  
O-rings: Viton or NBR  
Filter: 316L
- ⦿ Temperature: -15°F~+165°F (-26°C~+74°C)
- ⦿ Leak rates:  
Internal: Bubble-tight  
External: Bubble-tight
- ⦿ Flow coefficient (Cv): 0.06
- ⦿ Weight: ≈5.75 lbs (2.6 kg)
- ⦿ Body ports: 1/4" female NPT for inlet, outlet and gauge



Model: HPR-10SSN-100-100-00-00-ZV

### Flow Chart

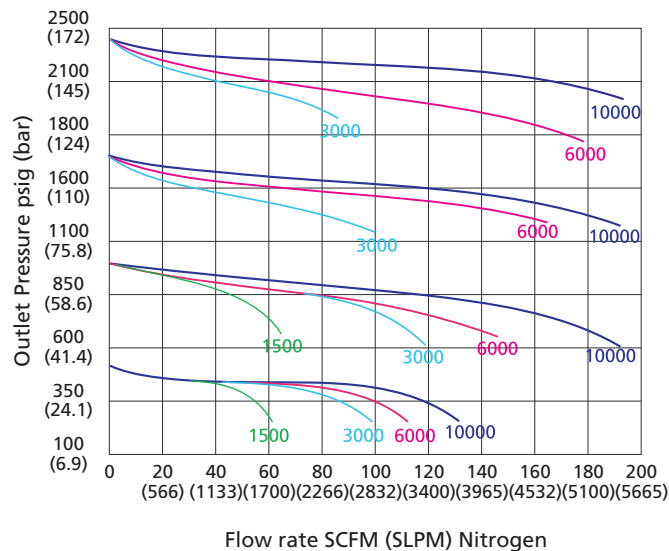

## Dimensions

Dimensions, in inches (millimeters), are for reference only.

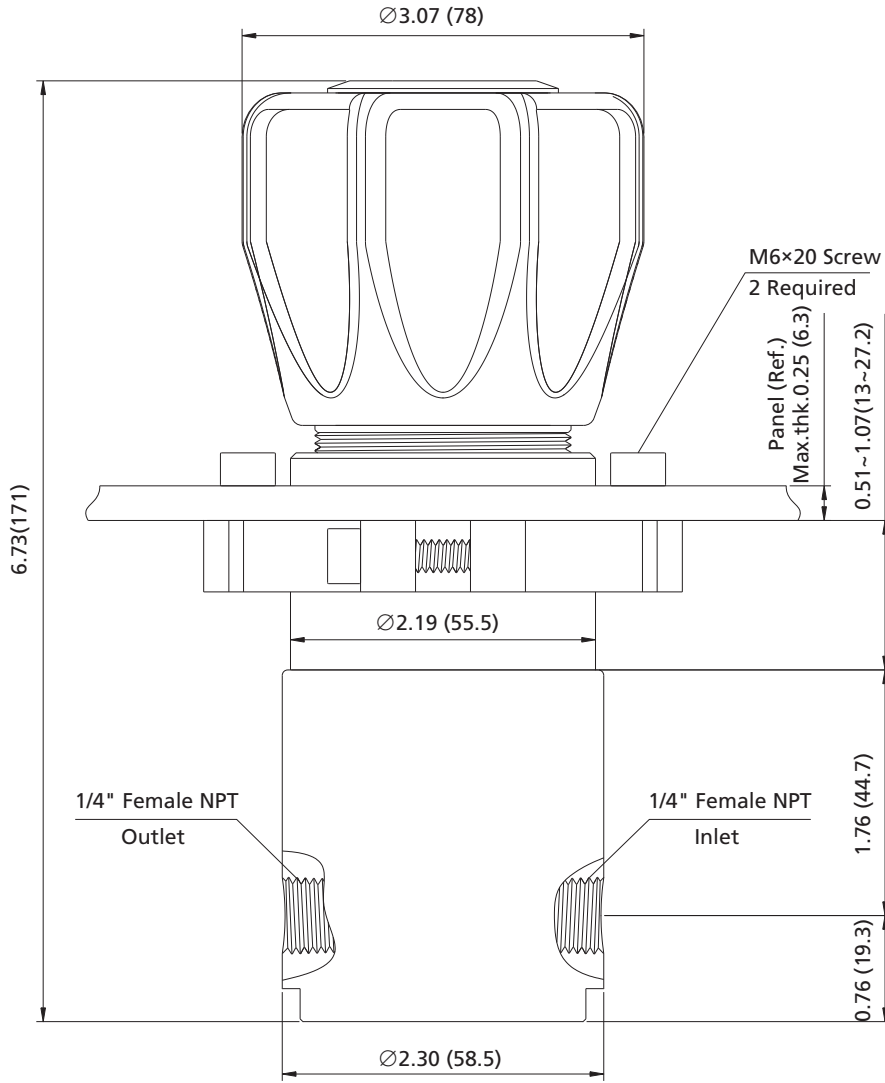

Panel Cut-outs

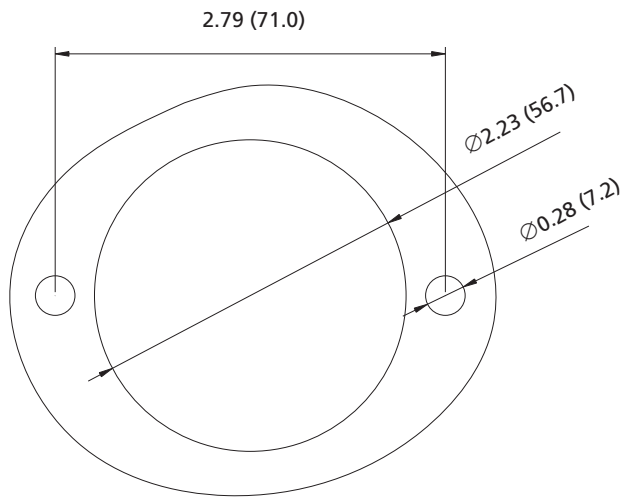

Bottom View

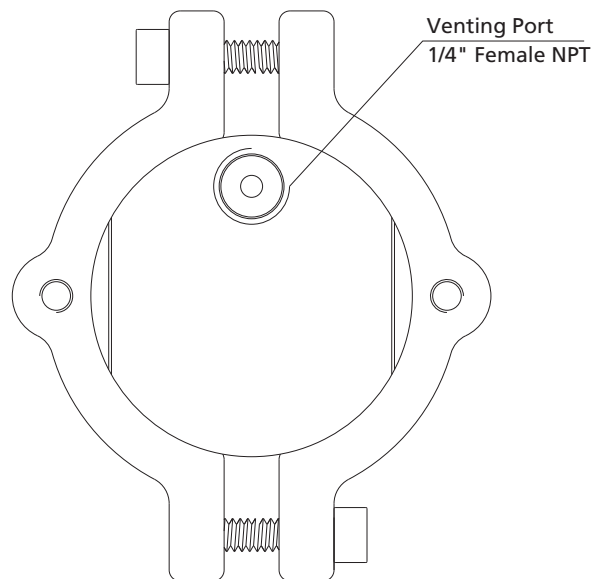

## Port Configurations

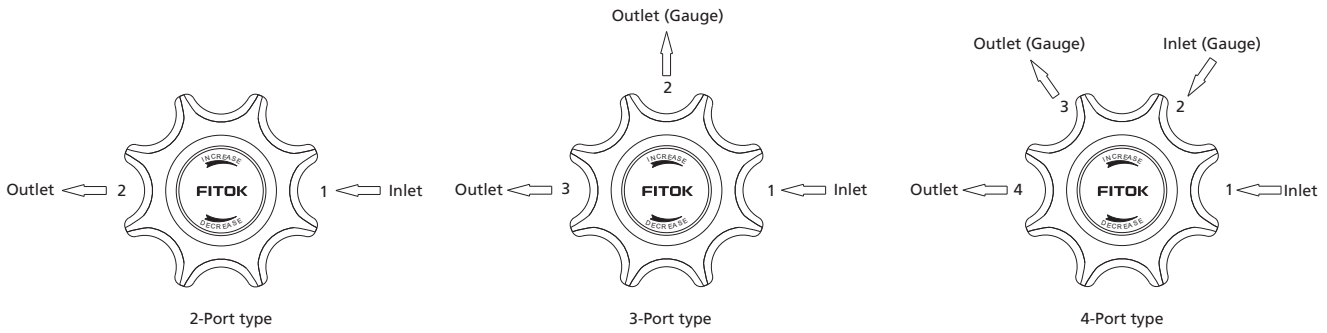

## Part Number Description

HPR - 10BN - 60 - 10 - 12 - B - B - 00 - ZV-F2

Body Material	Inlet Pressure P1	Connection 1	Connection 2	Connection 3	Panel Mount
SS 316 SS	60 6000 psig	00 1/4" Female NPT	B With Gauge (psi/bar)	Same as Connection 2	Without
B Brass (Max. Inlet Pressure 6000 psig)	100 10000 psig	01 1/4" Male NPT	M With Gauge (psi/MPa)		Z With
O-ring Material	Outlet Pressure Range P2	10 1/4" Tube Fitting	P Plug	Connection 4	Vent Option
Viton	5 10~500 psig	11 3/8" Tube Fitting	00 1/4" Female NPT	Same as Connection 1	Without
N NBR	8 15~800 psig	20 6 mm Tube Fitting	01 1/4" Male NPT		V With
	15 15~1500 psig	21 8 mm Tube Fitting	10 1/4" Tube Fitting		Product Technology Grade
	25 30~2500 psig	Other connections are available upon request	11 3/8" Tube Fitting		General Purpose
	40 50~4000 psig		20 6 mm Tube Fitting		F2 Special Cleaning and Packaging
	60 60~6000 psig		21 8 mm Tube Fitting		
	100 200~10000 psig		Other connections are available upon request		

Notes:

1. Most configurations are available but not everyone.
2. Venting port can not be blocked.
3. For liquid services, install the regulator with the venting port pointed vertically down.
4. Before ordering, please read **Installation Instructions and Cautions** on A-77.

Examples of part number:

- a. 2-port type (1 in, 1 out): HPR-10SS-60-40-00-00
- b. 3-port type (1 in, 2 out): HPR-10B-60-60-00-B-00
- c. 4-port type (2 in, 2 out): HPR-10SS-100-25-00-B-B-00

# Line Pressure Regulators

## HPL-06 Series High Pressure High Flow Regulators

### Features

- ⦿ For high pressure and high flow applications
- ⦿ Large piston sensor gives excellent sensitivity
- ⦿ Balanced valve design ensures stable downstream pressure
- ⦿ Three port configurations available
- ⦿ Panel mounting available
- ⦿ With special cleaning and packaging, applicable to oxygen-enriched environments

### Technical Data

- ⦿ Maximum inlet pressure:
  - Stainless steel: 4500 psig
  - Brass: 3750 psig
- ⦿ Outlet pressure ranges: 0~300, 0~600, 0~1000, 0~1500 psig
- ⦿ Material of the main components:
  - Body: 316 SS or brass
  - Seat: PCTFE
  - Piston: 316L
  - O-rings: Viton or Kalrez
- ⦿ Temperature: -15°F~+220°F (-26°C~+104°C)
- ⦿ Leak rates:
  - Internal: Bubble-tight
  - External: Bubble-tight
- ⦿ Flow coefficient (Cv): 2.0
- ⦿ Weight (regulator only): ≈ 6.25 lbs (2.83 Kg)
- ⦿ Body ports: 1/2" female NPT for inlet, outlet, 1/4" female NPT for gauge



Model: HPL-06SS-45-1000-04-04-Z

### Typical Flow Chart

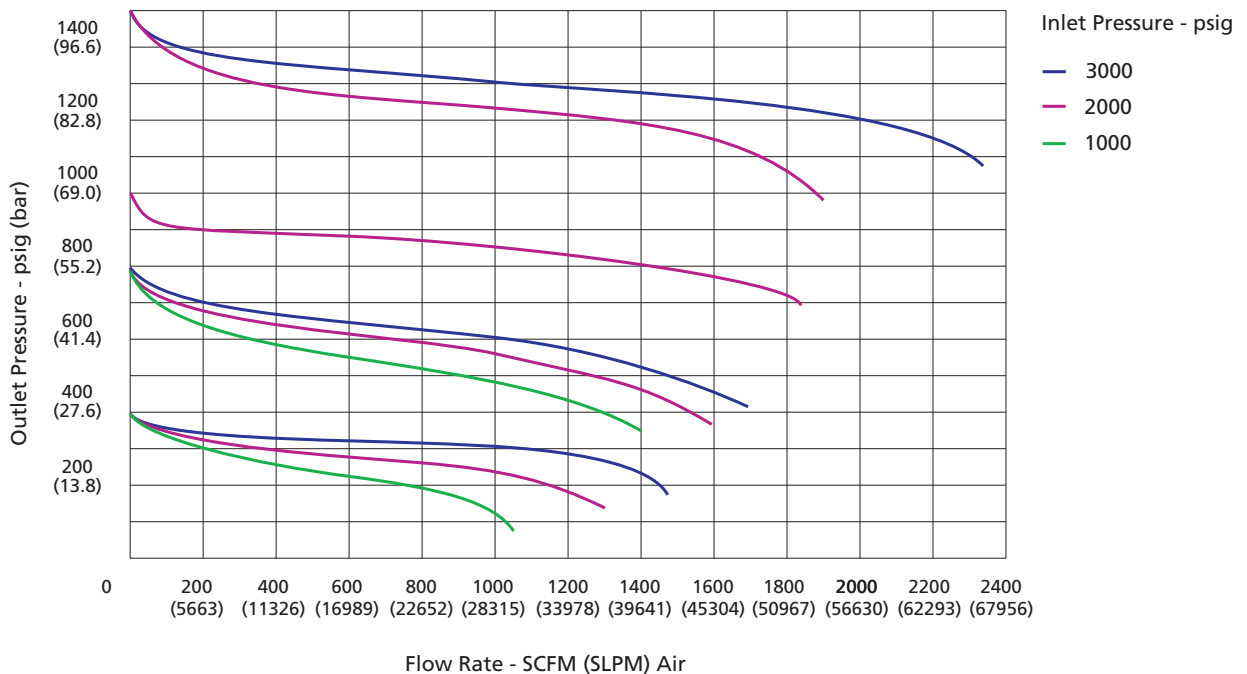

## Dimensions

Dimensions, in inches (millimeters), are for reference only.

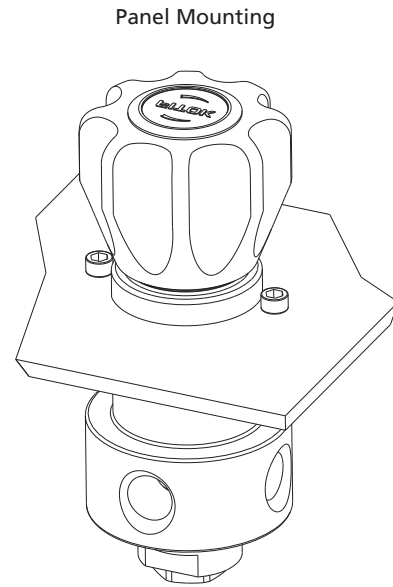
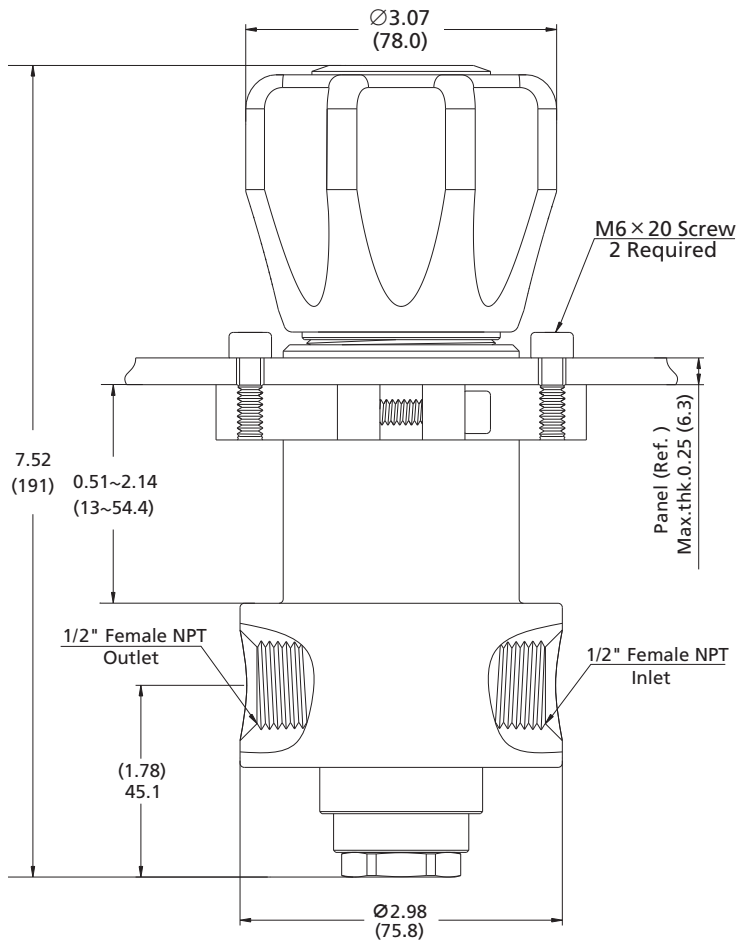

Panel Mounting Kit

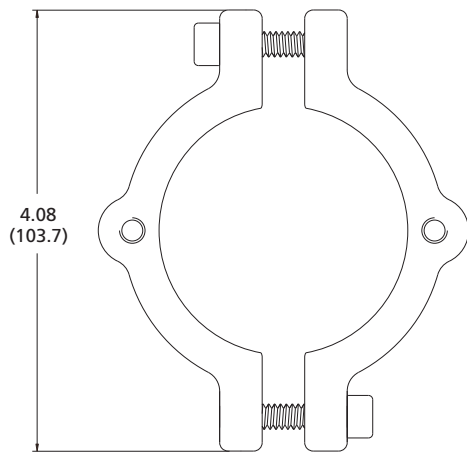

Panel Cut-out

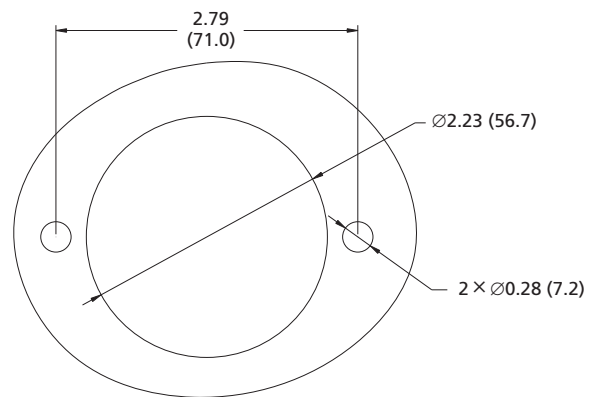

# Port Configurations

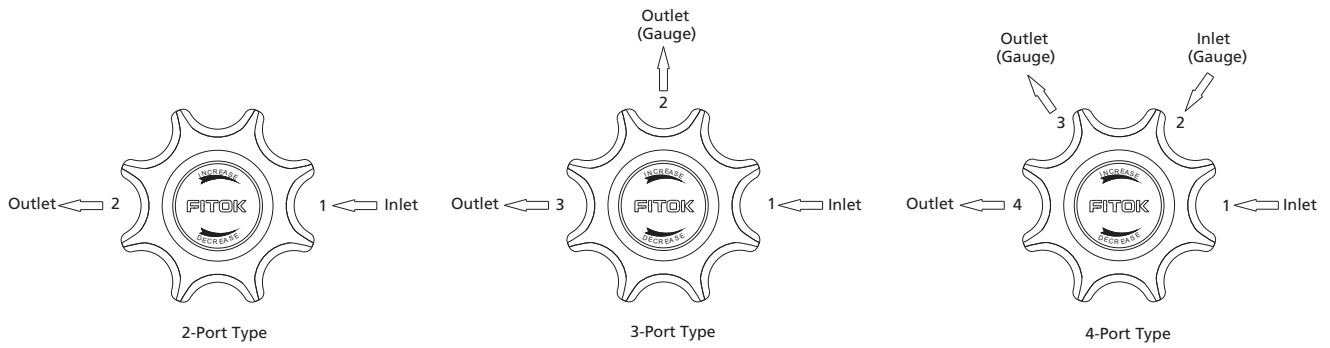

## Part Number Description

HPL - 06V Z      6L      -      45 - 600 - 04      -      B      -      B      -      04 - Z

Vent Option	Body Material	Inlet Pressure P1	Connection 1	Connection 2	Connection 3
Without	SS 316 SS	37 3750 psig	04 1/2" Female NPT	B With Gauge (psi/bar)	Same as Connection 2
V With	6L 316L SS	45 4500 psig	05 3/4" Female NPT	M With Gauge (psi/MPa)	
	Brass (Max. Inlet Pressure 3750 psig)		14 3/4" Tube Fitting	P Plug	<b>Connection 4</b>
	B	<b>Outlet Pressure Range P2</b>	25 16 mm Tube Fitting	00 1/4" Female NPT	Same as Connection 1
		300 0~300 psig	26 18 mm Tube Fitting	01 1/4" Male NPT	
		600 0~600 psig	Other connections are available upon request	10 1/4" Tube Fitting	<b>Panel Mount</b>
		1000 0~1000 psig		11 3/8" Tube Fitting	Without
		1500 0~1500 psig		20 6 mm Tube Fitting	Z With
				21 8 mm Tube Fitting	
				Other connections are available upon request	

**Notes:**

- Most configurations are available.
- Before ordering, please read **Installation Instructions and Cautions** on A-77.

Examples of part number:

- 2-Port type (1 in, 1 out): HPL-06B-37-600-04-04
- 3-Port type (1 in, 2 out): HPL-066L-45-1000-04-B-04
- 4-Port type (2 in, 2 out): HPL-065S-45-1500-04-B-B-04

# Pressure Control Panels

## FSR-1 Series Pressure Control Panels for Single Cylinder

### Features

- ⦿ With a FCR-1 Series Regulator
- ⦿ Maximum inlet pressure up to 4500 psig
- ⦿ With vent valves to relieve residual pressure quickly, easy and safe to remove and replace gas source
- ⦿ Anodized Aluminium panel
- ⦿ Bracket mounting as standard



Model: FSR-16L-45-100-00-B-B-00-R-P

### Technical Data

- ⦿ Maximum inlet pressure: 3000 or 4500 psig
- ⦿ Outlet pressure range: 0~25, 0~50, 0~100, 0~250 or 0~500 psig
- ⦿ Material of the main components:
  - Seat: PCTFE (regulator and diaphragm valve)
  - Diaphragm: Hastelloy (regulator), Elgiloy (diaphragm valve)
  - Diaphragm valve body: 316L
  - Filter: 316L
- ⦿ Temperature: -10°F~+150°F (-23°C~+65°C)
- ⦿ Leak rates:
  - Internal:  $\leq 1 \times 10^{-7}$  mbar·l/s helium
  - External:  $\leq 1 \times 10^{-9}$  mbar·l/s helium
- ⦿ Flow coefficient (regulator Cv): 0.06

### Typical Flow Chart

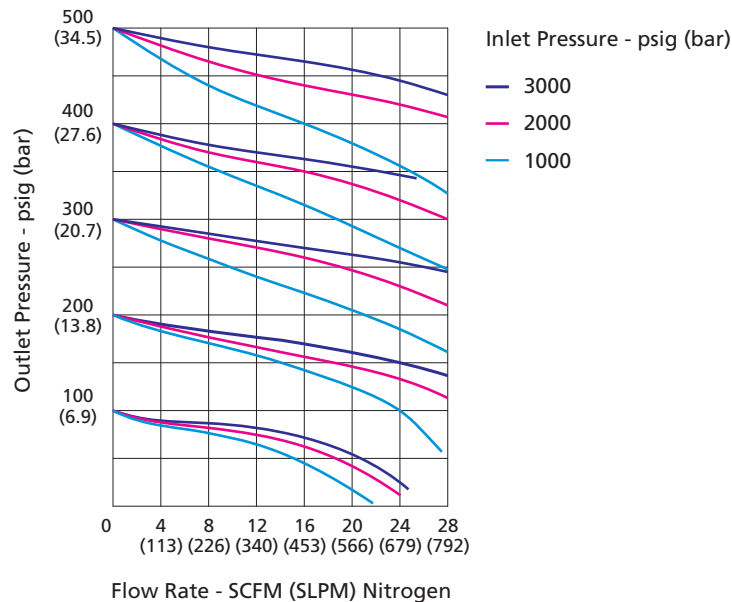

## Flow Schematic

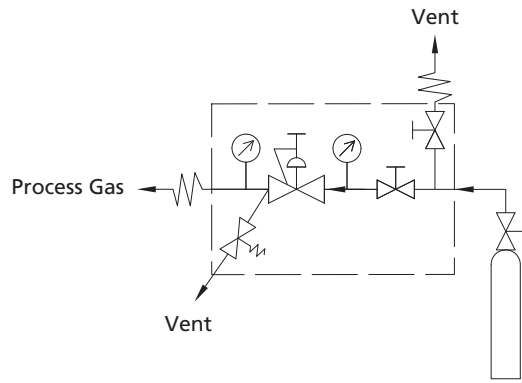

## Dimensions

Dimensions, in inches (millimeters), are for reference only.

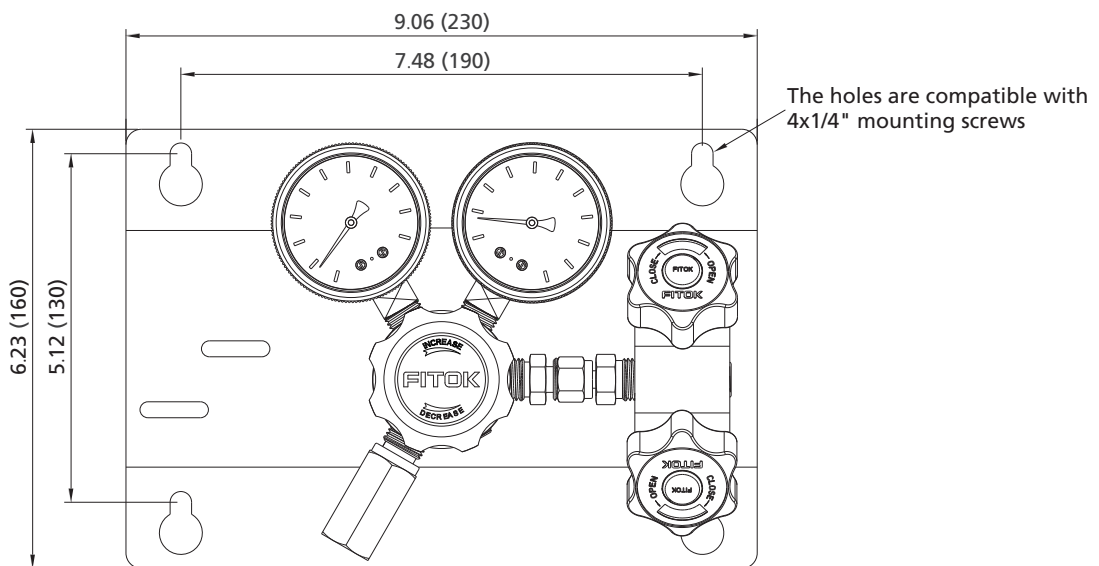
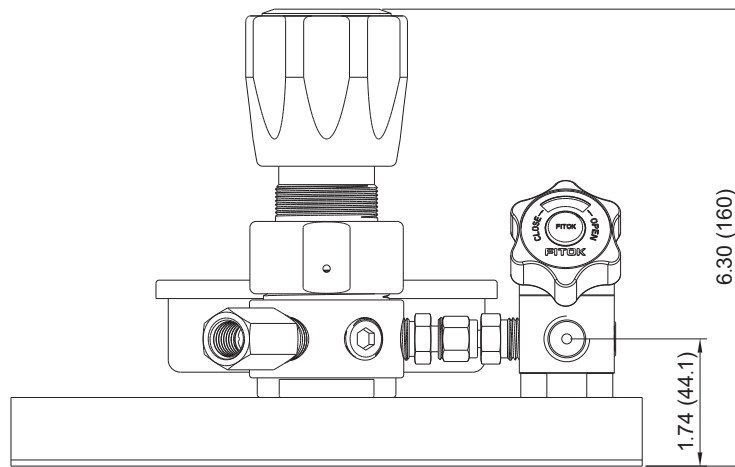



# Components Introduction

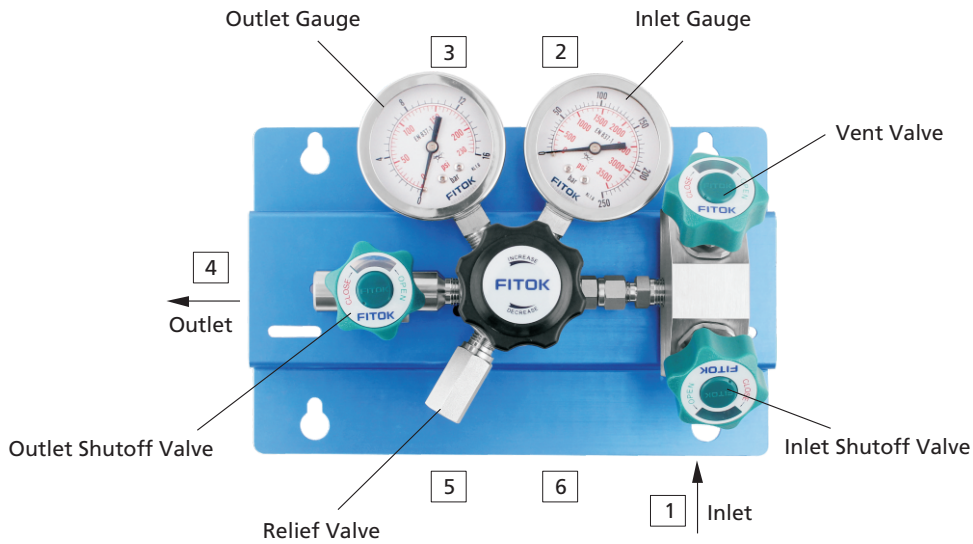

## Part Number Description

FSR - 16L - 30 - 50 - 00 - B - B - 30 - R - P

Body Material (Regulator)	Connection 1	Connection 2	Connection 4	Connection 5
6L 316L SS	00 1/4" Female NPT	B With Gauge (psi/bar)	00 1/4" Female NPT	R Relief Valve
SS 316 SS	01 1/4" Male NPT	M With Gauge (psi/MPa)	01 1/4" Male NPT	P Plug
HC Hastelloy C-276	10 1/4" Tube Fitting	P Plug	10 1/4" Tube Fitting	00 1/4" Female NPT
B Brass (Nickel-plated)	11 3/8" Tube Fitting	00 1/4" Female NPT	11 3/8" Tube Fitting	
	20 6 mm Tube Fitting		20 6 mm Tube Fitting	
	21 8 mm Tube Fitting		21 8 mm Tube Fitting	
	Other connections are available upon request		30 Diaphragm Valve with 1/4" Female NPT	
			31 Diaphragm Valve with 1/4" Male NPT	
			32 Diaphragm Valve with 1/4" Tube Fitting	
			33 Diaphragm Valve with 3/8" Tube Fitting	
			34 Diaphragm Valve with 6 mm Tube Fitting	
			35 Diaphragm Valve with 8 mm Tube Fitting	
			Other connections are available upon request	

Inlet Pressure P1	Connection 3	Connection 6
30 3000 psig	Same as Connection 2	Same as Connection 5
45 4500 psig		

Outlet Pressure Range P2
25 0~25 psig
50 0~50 psig
100 0~100 psig
250 0~250 psig
500 0~500 psig

Notes:

1. Most configurations are available.
2. Before ordering, please read **Installation Instructions and Cautions** on A-77.

# Pressure Control Panels

## FSR-2 Series High Pressure Control Panels for Single Cylinder

### Features

- ⦿ With a FCR-2 Series Regulator
- ⦿ Applicable to non-corrosive gases or low-viscosity liquids
- ⦿ With vent valves to relieve residual pressure quickly, easy and safe to remove and replace gas source
- ⦿ Venting model available
- ⦿ Anodized Aluminium panel
- ⦿ Bracket mounting as standard

### Technical Data

- ⦿ Maximum inlet pressure: 3000 or 4500 psig
- ⦿ Outlet pressure range: 0~750, 0~1500 or 0~2500 psig
- ⦿ Material of the main components:
  - Seat: PCTFE (regulator and diaphragm valve)
  - Piston: 316L
  - Diaphragm: Elgiloy (diaphragm valve)
  - Diaphragm valve body: 316L
  - O-ring: Viton or Kalrez
  - Filter: 316L
- ⦿ Temperature: -10°F~+150°F (-23°C~+65°C)
- ⦿ Leak rates:
  - Internal: Bubble-tight
  - External: Bubble-tight
- ⦿ Flow coefficient (regulator Cv):
  - Without vent: 0.06
  - With vent: 0.1



Model: FSR-2Z6L-45-750-00-B-B-00-P-P

### Typical Flow Chart

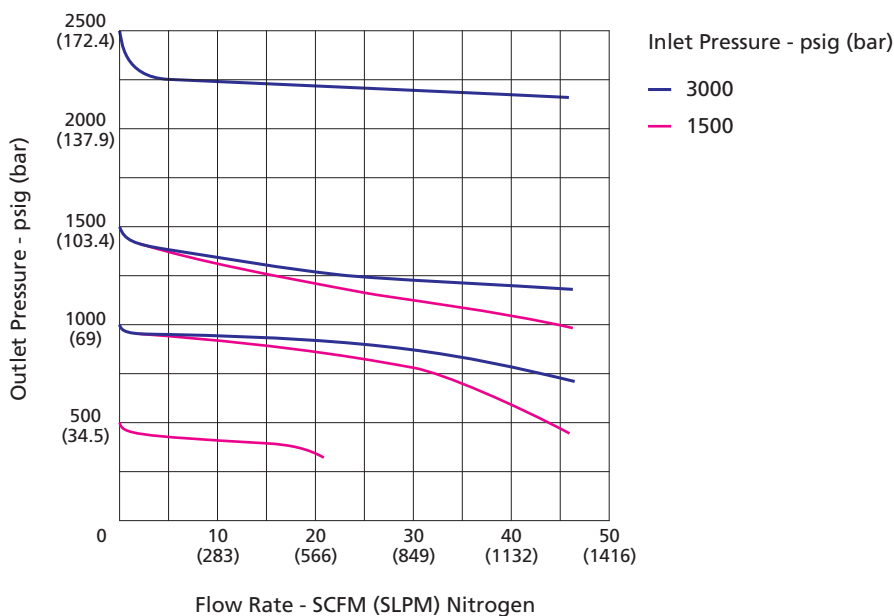

## Flow Schematic

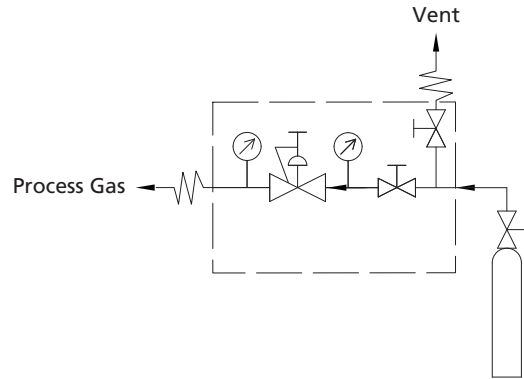

## Dimensions

Dimensions, in inches (millimeters), are for reference only.

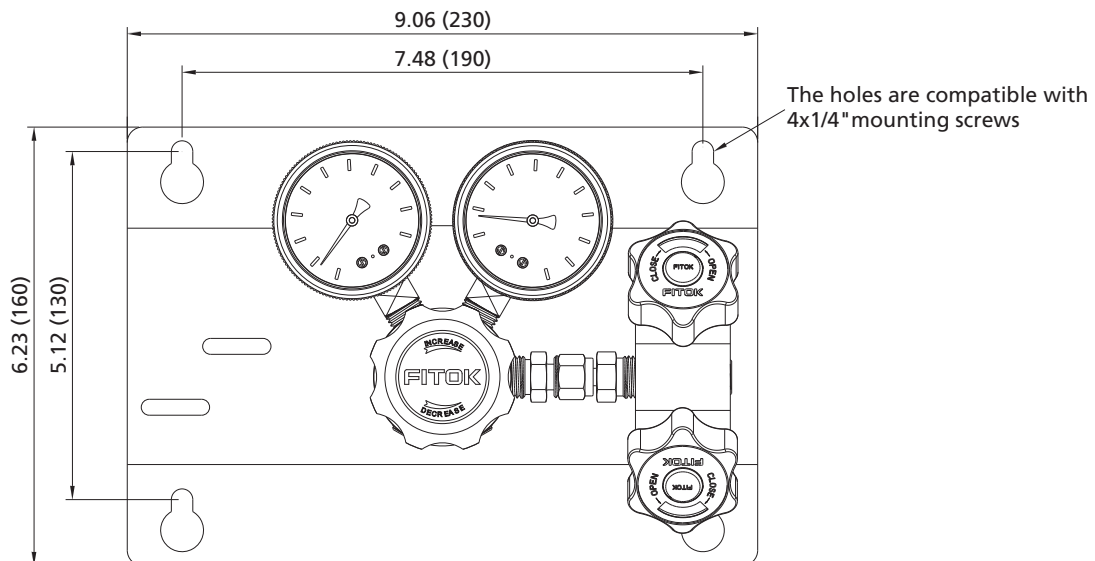
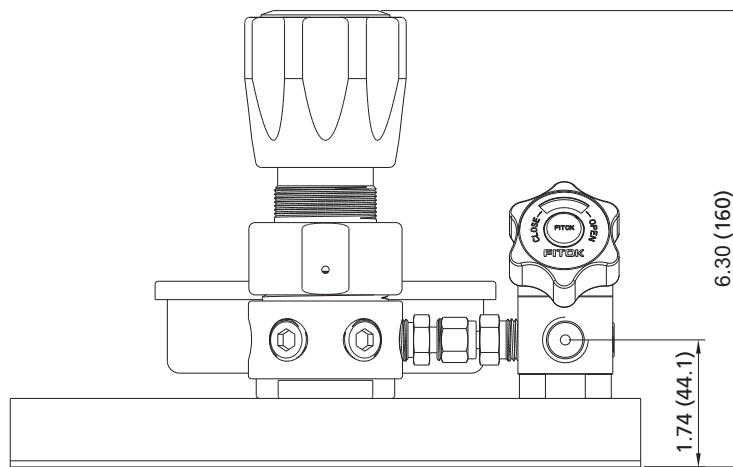

# Components Introduction

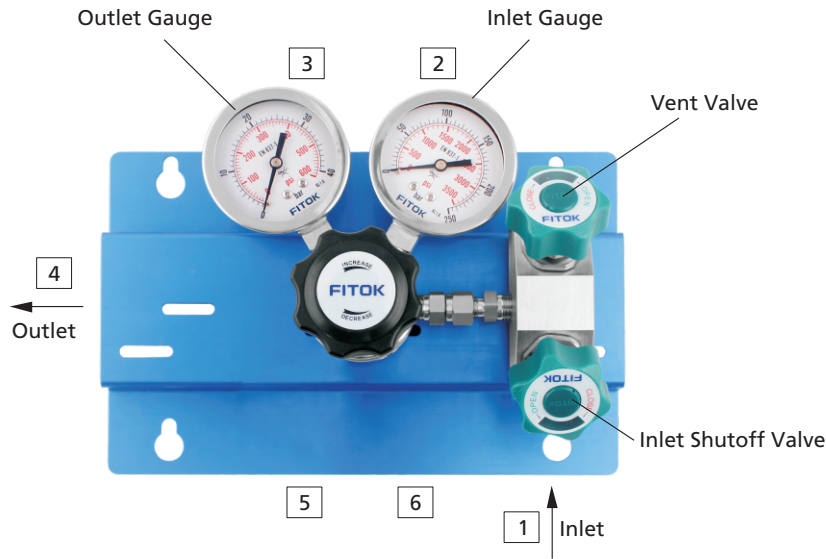

## Part Number Description

**FSR - 2V Z 6L - 30 - 1500 - 00 - B - B - 30 - P - P**

Vent Option	Inlet Pressure P1	Connection 1	Connection 2	Connection 4	Connection 5
Without	30 3000 psig	00 1/4" Female NPT	B With Gauge (psi/bar)	00 1/4" Female NPT	R Relief Valve
V With	45 4500 psig	01 1/4" Male NPT	M With Gauge (psi/MPa)	01 1/4" Male NPT	P Plug
O-ring Material	Outlet Pressure Range P2	10 1/4" Tube Fitting	P Plug	10 1/4" Tube Fitting	00 1/4" Female NPT
Viton	750 0~750 psig	11 3/8" Tube Fitting	00 1/4" Female NPT	11 3/8" Tube Fitting	Connection 6
Z Kalrez	1500 0~1500 psig	20 6 mm Tube Fitting	Connection 3	20 6 mm Tube Fitting	Same as Connection 5
Body Material (Regulator)	2500 0~2500 psig	21 8 mm Tube Fitting	Same as Connection 2	21 8 mm Tube Fitting	
6L 316L SS		Other connections are available upon request		30 Diaphragm Valve with 1/4" Female NPT	
SS 316 SS				31 Diaphragm Valve with 1/4" Male NPT	
B Brass (Nickel-plated)				32 Diaphragm Valve with 1/4" Tube Fitting	
				33 Diaphragm Valve with 3/8" Tube Fitting	
				34 Diaphragm Valve with 6 mm Tube Fitting	
				35 Diaphragm Valve with 8 mm Tube Fitting	
				Other connections are available upon request	

**Notes:**

1. Most configurations are available.
2. Before ordering, please read **Installation Instructions and Cautions** on A-77.

# Changeover Systems

## FDR-1 Series Manual Changeover System (up to 500 psig)

### Features

- ⦿ A small manual changeover system with a regulator similar to FCR-1 Series Regulators
- ⦿ Connecting with two independent gas sources at a time, gas source selected through diaphragm valves
- ⦿ Applicable to corrosive or toxic gases
- ⦿ With vent valves to relieve residual pressure quickly, easy and safe to remove and replace gas source
- ⦿ Anodized Aluminium panel

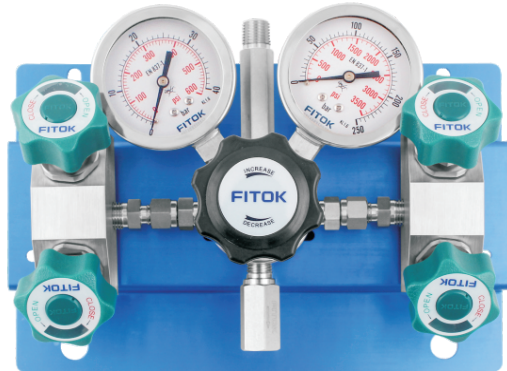

Model: FDR-16L-30-500-00-B-B-01-00-R

### Technical Data

- ⦿ Maximum inlet pressure: 3000 or 4500 psig
- ⦿ Outlet pressure range: 0~25, 0~50, 0~100, 0~250 or 0~500 psig
- ⦿ Material of the main components:
  - Seat: PCTFE (regulator and diaphragm valve)
  - Diaphragm: Hastelloy (regulator), Elgiloy (diaphragm valve)
  - Diaphragm valve body: 316L
  - O-ring: Viton
- ⦿ Temperature: -10°F~+150°F (-23°C~+65°C)
- ⦿ Leak rates:
  - Internal:  $\leq 1 \times 10^{-7}$  mbar·l/s helium
  - External:  $\leq 1 \times 10^{-9}$  mbar·l/s helium
- ⦿ Flow coefficient (regulator Cv): 0.06

### Typical Flow Chart

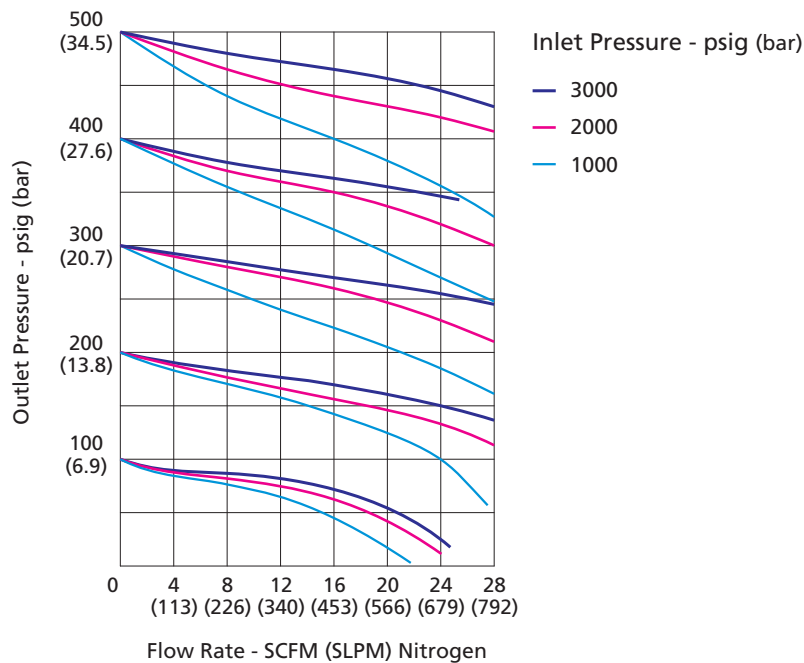

## Flow Schematic

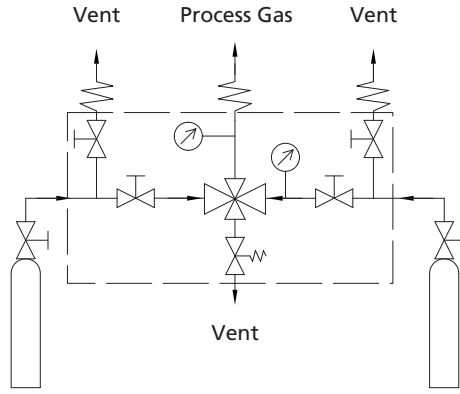

## Dimensions

Dimensions, in inches (millimeters), are for reference only.

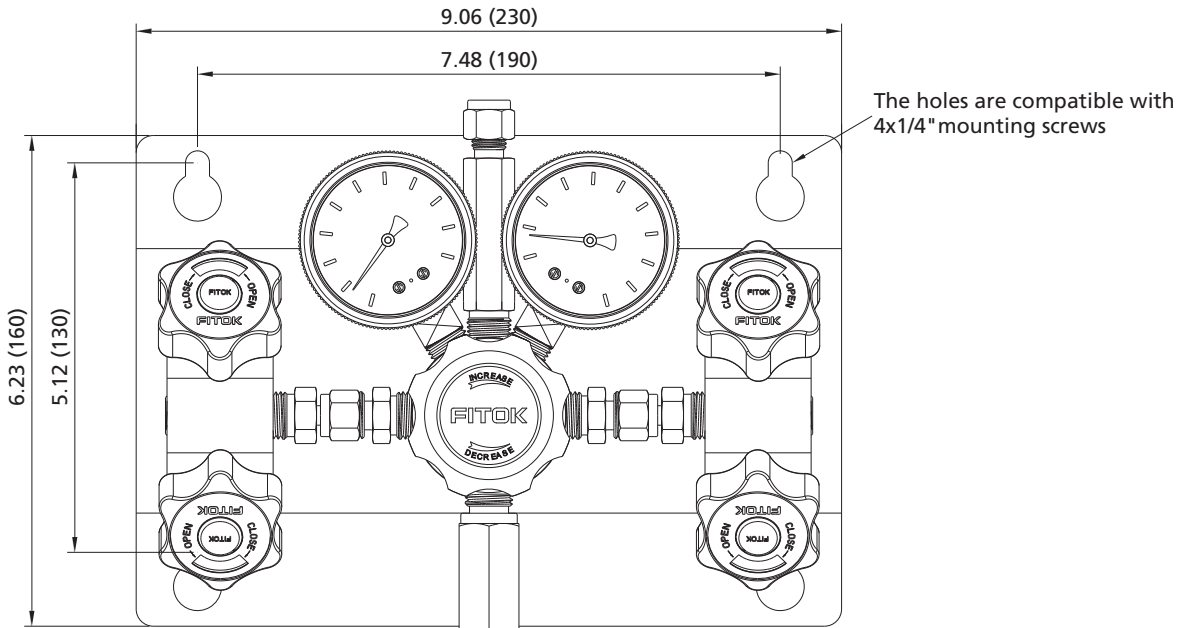
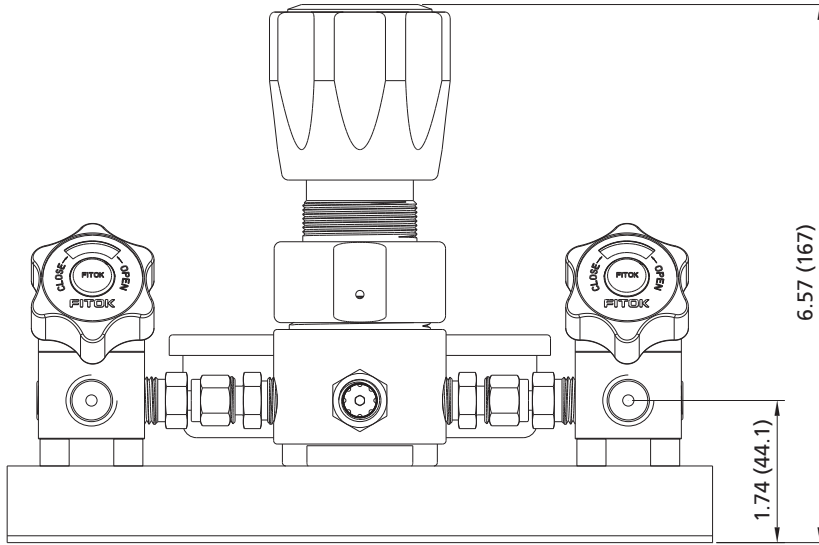

## Components Introduction

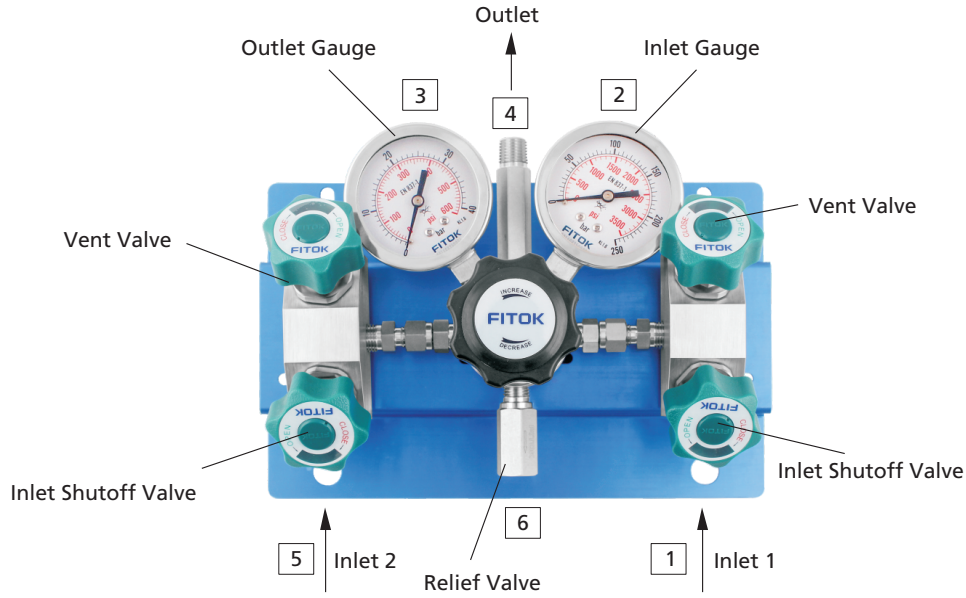

## Part Number Description

FDR - 16L - 30 - 250 - 00 - B - B - 01 - 00 - R

Body Material (Regulator)	
6L	316L SS
SS	316 SS
HC	Hastelloy C-276
B	Brass (Nickel-plated)

Inlet Pressure P1	
30	3000 psig
45	4500 psig

Outlet Pressure Range P2	
25	0~25 psig
50	0~50 psig
100	0~100 psig
250	0~250 psig
500	0~500 psig

Connection 1	
00	1/4" Female NPT
01	1/4" Male NPT
10	1/4" Tube Fitting
11	3/8" Tube Fitting
20	6 mm Tube Fitting
21	8 mm Tube Fitting
Other connections are available upon request	

Connection 2	
B	With Gauge (psi/bar)
M	With Gauge (psi/MPa)
P	Plug
00	1/4" Female NPT

Connection 3	
Same as Connection 2	

Connection 4	
00	1/4" Female NPT
01	1/4" Male NPT
10	1/4" Tube Fitting
11	3/8" Tube Fitting
20	6 mm Tube Fitting
21	8 mm Tube Fitting
Other connections are available upon request	

Connection 6	
R	Relief Valve
P	Plug
00	1/4" Female NPT

Connection 5	
Same as Connection 1	

Note: Before ordering, please read **Installation Instructions and Cautions** on A-77.

# Changeover Systems

## FDR-2 Series Manual Changeover System (up to 2500 psig)

### Features

- ⦿ A small manual changeover system with a regulator similar to FCR-2 Series Regulators
- ⦿ Connecting with two independent gas sources at a time, gas sources switched through diaphragm valves
- ⦿ Applicable to non-corrosive gases
- ⦿ Venting model available
- ⦿ Anodized Aluminium panel



Model: FDR-2VSS-45-2500-00-B-B-01-00

### Technical Data

- ⦿ Maximum inlet pressure: 3000 or 4500 psig
- ⦿ Outlet pressure range: 0~750, 0~1500 or 0~2500 psig
- ⦿ Material of the main components:
  - Seat: PCTFE (regulator and diaphragm valve)
  - Piston: 316L
  - Diaphragm: Elgiloy (diaphragm valve)
  - Diaphragm valve body: 316L
  - O-ring: Viton or Kalrez
  - Filter: 316L
- ⦿ Temperature: -10°F~+150°F (-23°C~+65°C)
- ⦿ Leak rates:
  - Internal: Bubble-tight
  - External: Bubble-tight
- ⦿ Flow coefficient (regulator Cv):
  - Without vent: 0.06
  - Vent: 0.1

### Typical Flow Chart

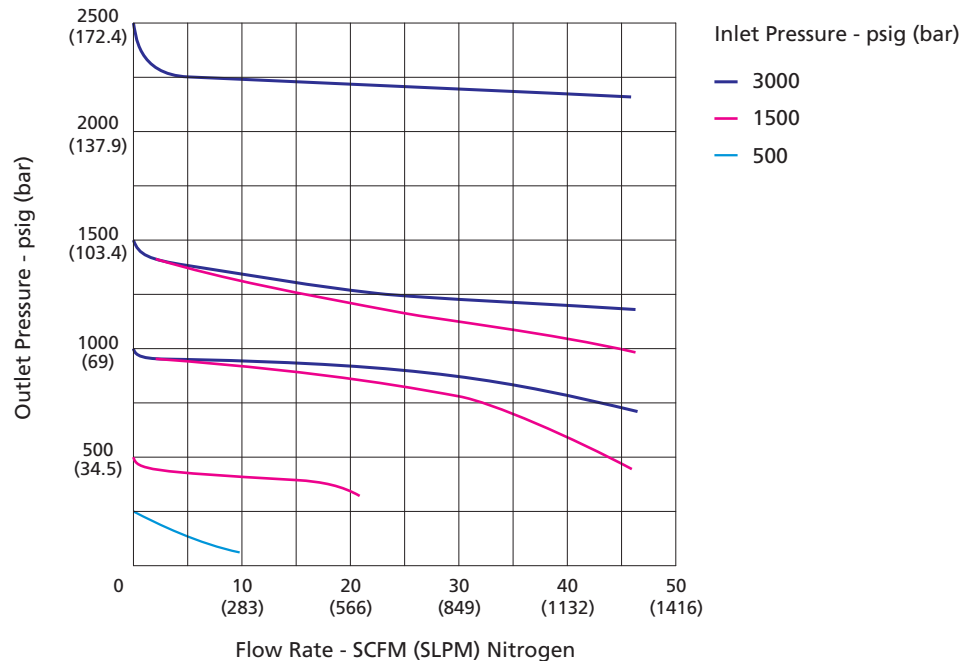



## Flow Schematic

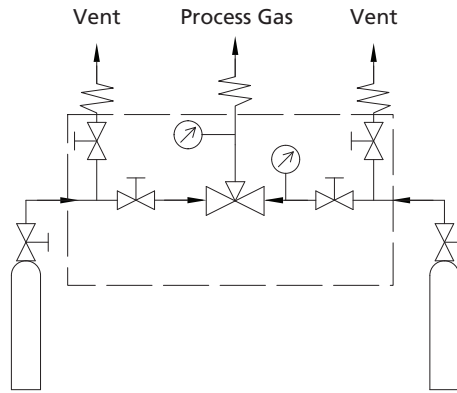

## Dimensions

Dimensions, in inches (millimeters), are for reference only.

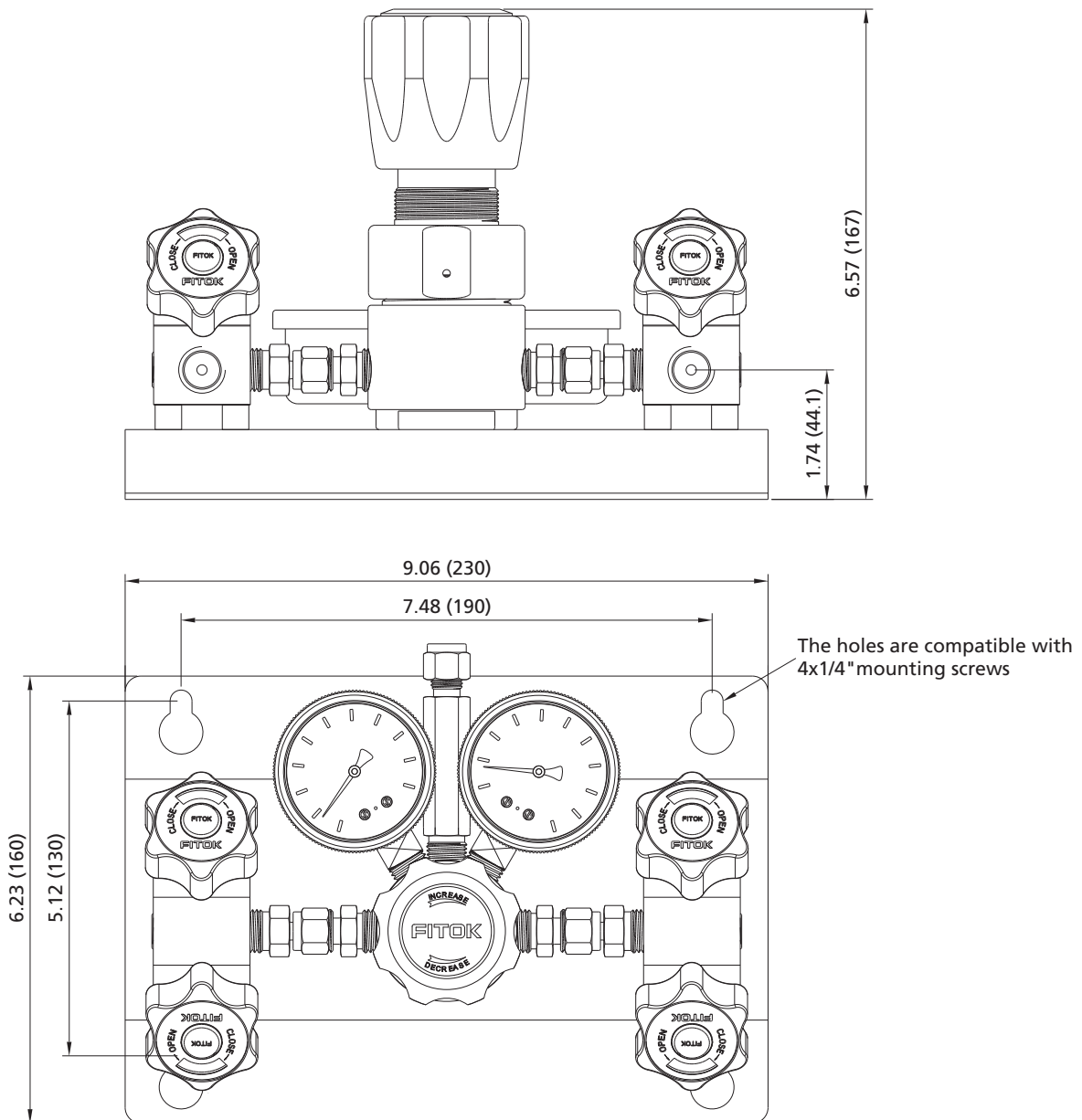

# Components Introduction

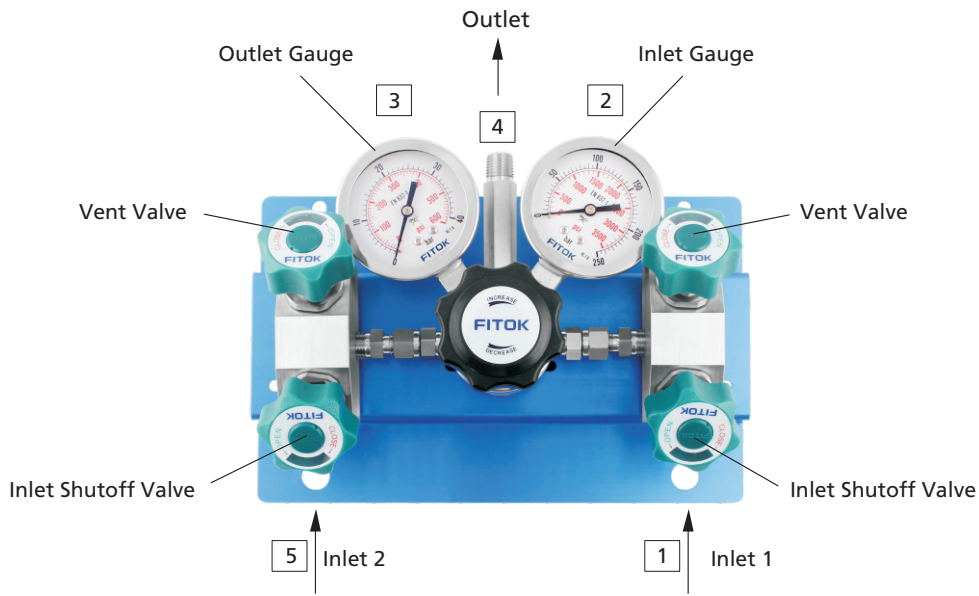

## Part Number Description

FDR - 2V Z 6L - 30 - 750 - 00 - B - B - 01 - 00

Vent Option	Inlet Pressure P1	Connection 1	Connection 2	Connection 4	Connection 5
Without	30 3000 psig	00 1/4" Female NPT	B With Gauge (psi/bar)	00 1/4" Female NPT	Same as Connection 1
V With	45 4500 psig	01 1/4" Male NPT	M With Gauge (psi/MPa)	01 1/4" Male NPT	
O-ring Material	Outlet Pressure Range P2	10 1/4" Tube Fitting	P Plug	10 1/4" Tube Fitting	
Viton	750 0~750 psig	11 3/8" Tube Fitting	00 1/4" Female NPT	11 3/8" Tube Fitting	
Z Kalrez	1500 0~1500 psig	20 6 mm Tube Fitting	Connection 3 Same as Connection 2	20 6 mm Tube Fitting	
Body Material (Regulator)	2500 0~2500 psig	21 8 mm Tube Fitting		Other connections are available upon request	21 8 mm Tube Fitting
6L 316L SS	Other connections are available upon request				
SS 316 SS					
B Brass (Nickel-plated)					

Note: Before ordering, please read **Installation Instructions and Cautions** on A-77.

# Changeover Systems

## FDR-1L Series Automatic Changeover System without Line Pressure Regulator

### Features

- With 2 regulators similar to FCR-1 Series Regulators
- Anodized Aluminium box with clearly marked panel
- With vent valves to relieve residual pressure quickly, easy and safe to remove and replace gas source
- Automatic switching of gas source to ensure continuous gas supply
- Four fixed outlet pressure ranges available
- With special cleaning and packaging, applicable to oxygen-enriched environments



Model: FDR-1L6L-30-10B-00-00-00

### Technical Data

- Maximum inlet pressure: 3000 or 4500 psig
- Outlet pressure range: 85~115, 135~165, 185~215 or 235~265 psig
- Material of the main components:
  - Seat: PCTFE (regulator and diaphragm valve)
  - Diaphragm: Hastelloy (regulator), Elgiloy (diaphragm valve)
  - Diaphragm valve body: 316L
- Temperature: -10°F~+150°F (-23°C~+65°C)
- Leak rates:
  - Internal:  $\leq 1 \times 10^{-7}$  mbar·l/s helium
  - External:  $\leq 1 \times 10^{-9}$  mbar·l/s helium
- Flow coefficient (regulator Cv): 0.06
- Weight:  $\approx 12.1$  lbs (5.5 kg)

### Flow Schematic

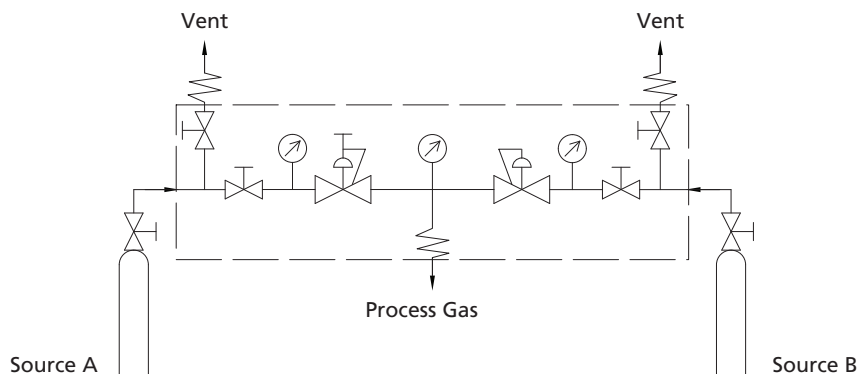

## Operation Overview

The FDR-1L Series Changeover System is mainly comprised of one adjustable outlet pressure regulator together with one fixed outlet pressure regulator.

When the 2 inlets are both open, the one side that the "IN SERVICE" arrow is pointing at by turning the handle would be the 1st source for gas supply.

Fig. 1 When the "In Service" arrow is pointing at side B, side B would be the gas source. At this time, the fixed outlet pressure of side B is higher than the set pressure of side A. Consequently, the diaphragm of side A regulator moves to enable the stem to close the regulator.

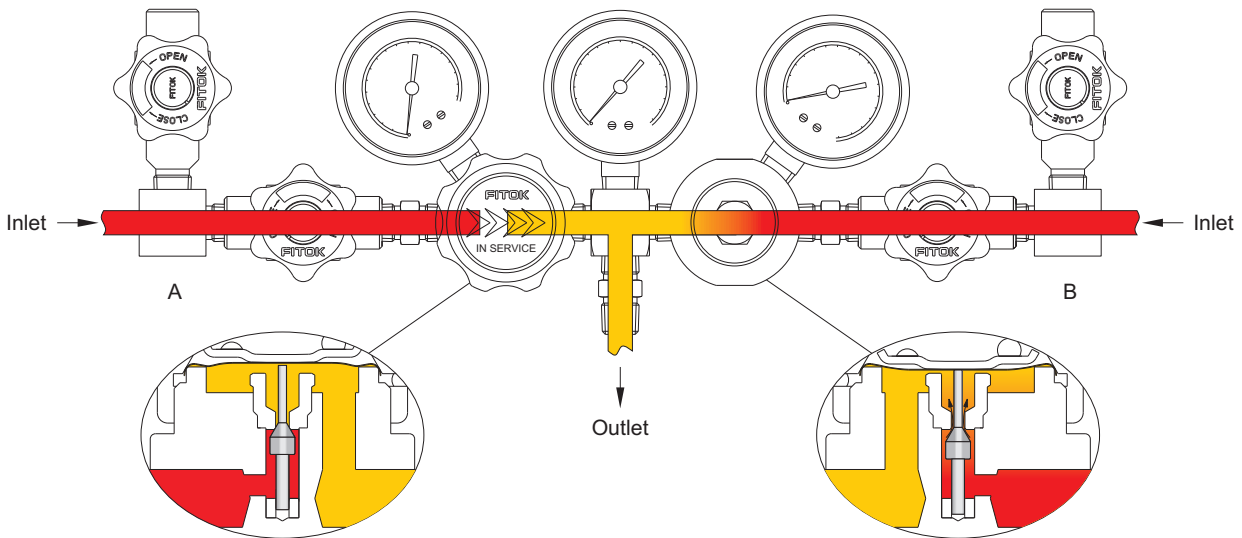

Fig. 1

Fig. 2 If side A is chosen as the gas source, the handle should be turned clockwise until the "IN SERVICE" arrow is pointing at side A. At this time, the set pressure of side A is higher than the fixed outlet pressure of side B. Consequently, the diaphragm of side B regulator moves to enable stem to close the regulator.

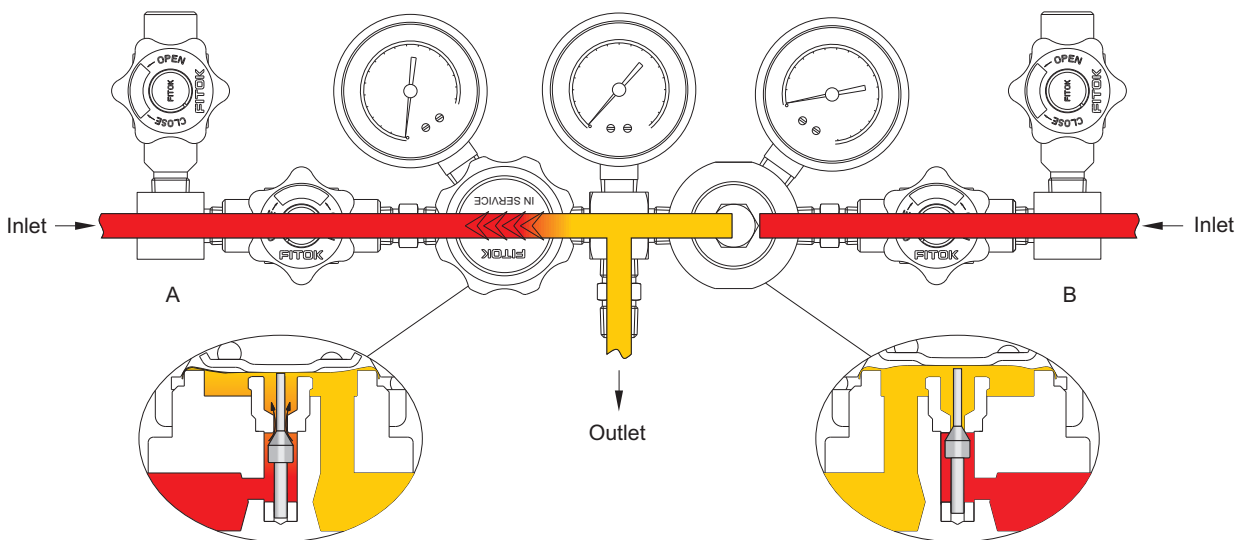

Fig. 2

When gas source of one side is depleted, gas source would automatically change to the other side.

Fig. 3 When "IN SERVICE" arrow is pointing at side B, but gas source of side B is depleted, its outlet pressure shall decrease to be lower than the set pressure of side A. By the force of spring, side A regulator will be opened to begin gas supply.

Before replacing new gas source of side B, the diaphragm valve should be turned off. Otherwise, gas from side A will flow back into side B. Then open the vent valve to exhaust the remaining pressure.

After the replacement, if the "IN SERVICE" arrow still points at side B, side B would be the gas source. If the arrow is turned towards side A, side A would thus be the gas source.

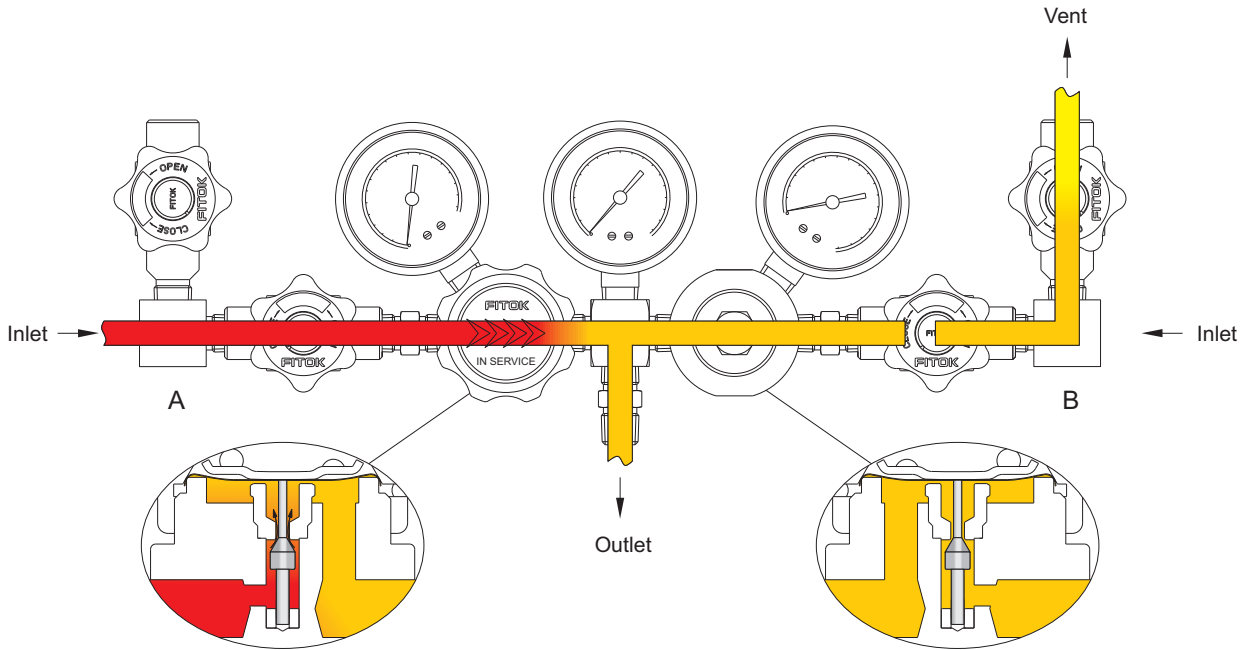
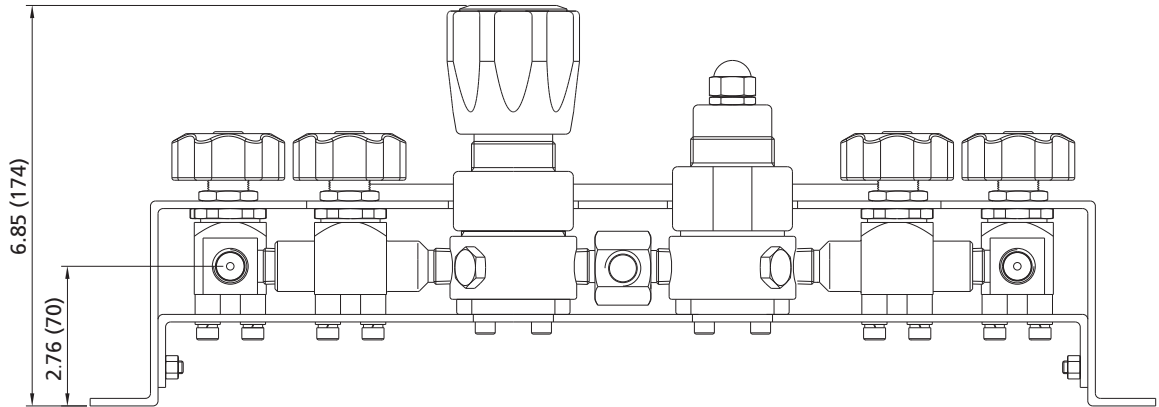
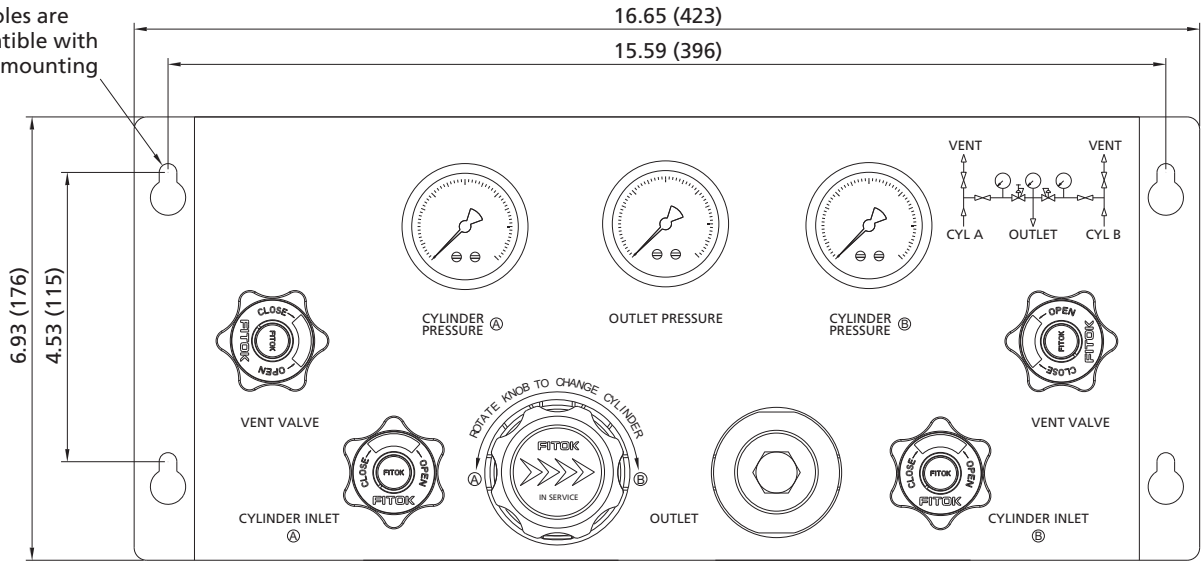

Fig. 3

## Dimensions

Dimensions, in inches (millimeters), are for reference only.

The holes are compatible with 4x1/4" mounting screws



## Part Number Description

FDR - 1L6L - 30 - 20 - B - 10 - 00 - 00

Body Material (Regulator)	Inlet Pressure P1	Outlet Pressure Range P2	Gauge Scale	Inlet A	Inlet B	Outlet
6L 316L SS	30 3000 psig	10 85~115 psig	B psi/bar	00 1/4" Female NPT	Same as Inlet A	Same as Inlet A
SS 316 SS	45 4500 psig	15 135~165 psig	M psi/MPa	01 1/4" Male NPT		
HC Hastelloy C-276		20 185~215 psig		10 1/4" Tube Fitting		
B Brass (Nickel-plated)		25 235~265 psig		11 3/8" Tube Fitting		
				20 6 mm Tube Fitting		
				21 8 mm Tube Fitting		

Note: Before ordering, please read **Installation Instructions and Cautions** on A-77.

Other connections are available upon request

# Changeover Systems

## FDR-1T Series Automatic Changeover System with Line Pressure Regulator

### Features

- ⦿ With a FCR-1 Series Regulator and a FLR-1 Series Regulator to enable outlet pressure adjustment
- ⦿ Anodized Aluminium box with clearly marked panel
- ⦿ With vent valves to relieve residual pressure quickly, easy and safe to remove and replace gas source
- ⦿ Automatic switching of gas source to ensure continuous gas supply
- ⦿ With special cleaning and packaging, applicable to oxygen-enriched environments

### Technical Data

- ⦿ Maximum inlet pressure: 3000 or 4500 psig
- ⦿ Outlet pressure range: 0~25, 0~50, 0~100 or 0~150 psig
- ⦿ Material of the main components:
  - Seat: PCTFE (regulator and diaphragm valve)
  - Diaphragm: Hastelloy (regulator), Elgiloy (diaphragm valve)
  - Diaphragm valve body: 316L
- ⦿ Temperature: -10°F~+150°F (-23°C~+65°C)
- ⦿ Leak rates:
  - Internal:  $\leq 1 \times 10^{-7}$  mbar·l/s helium
  - External:  $\leq 1 \times 10^{-9}$  mbar·l/s helium
- ⦿ Flow coefficient (regulator Cv): 0.05
- ⦿ Weight:  $\approx 19.6$  lbs (8.9 kg)

### Flow Schematic

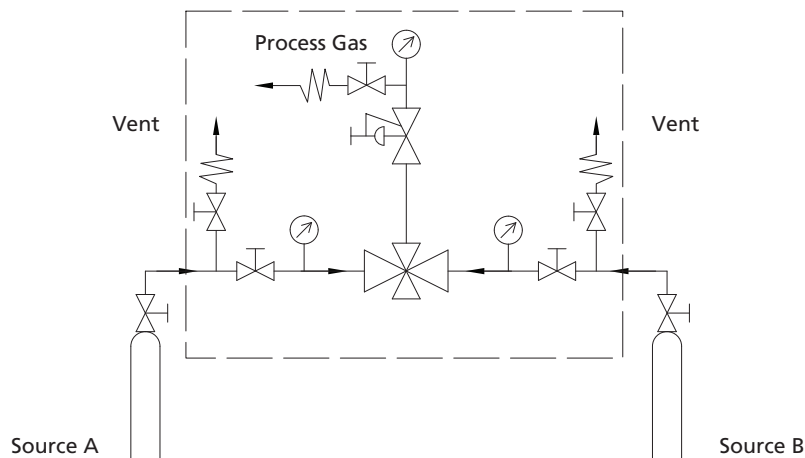

Model: FDR-1T6L-45-150B-00-00-00

## Operation Overview

The FDR-1T Series Changeover System is mainly comprised of one adjustable outlet pressure regulator and one fixed outlet pressure regulator, together with a line pressure regulator on the outlet port.

**When the 2 inlets are both open, the one side that the "IN SERVICE" arrow is pointing at by turning the handle would be the 1st source for gas supply.**

*Fig. 1* When the "In Service" arrow is pointing at side B, side B would be the gas source. At this time, the fixed outlet pressure of side B is higher than the set pressure of side A. Consequently, the diaphragm of side A regulator moves to enable the stem to close the regulator.

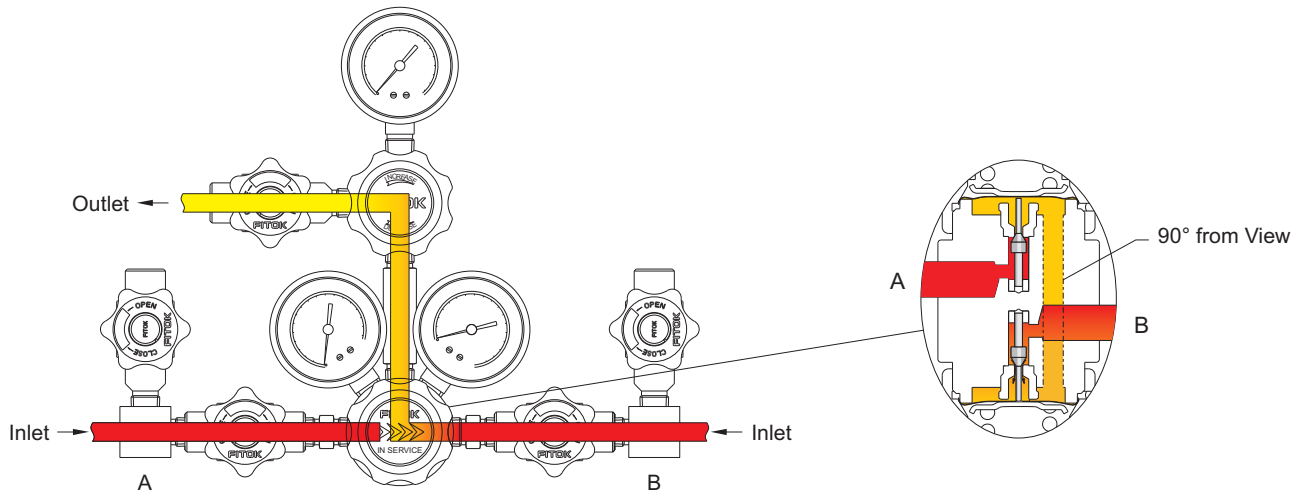

Fig. 1

*Fig. 2* If side A is chosen as the gas source, the handle should be turned clockwise until the "IN SERVICE" arrow is pointing at side A. At this time, the set pressure of side A is higher than the fixed outlet pressure of side B. Consequently, the diaphragm of side B regulator moves to enable the stem to close the regulator.

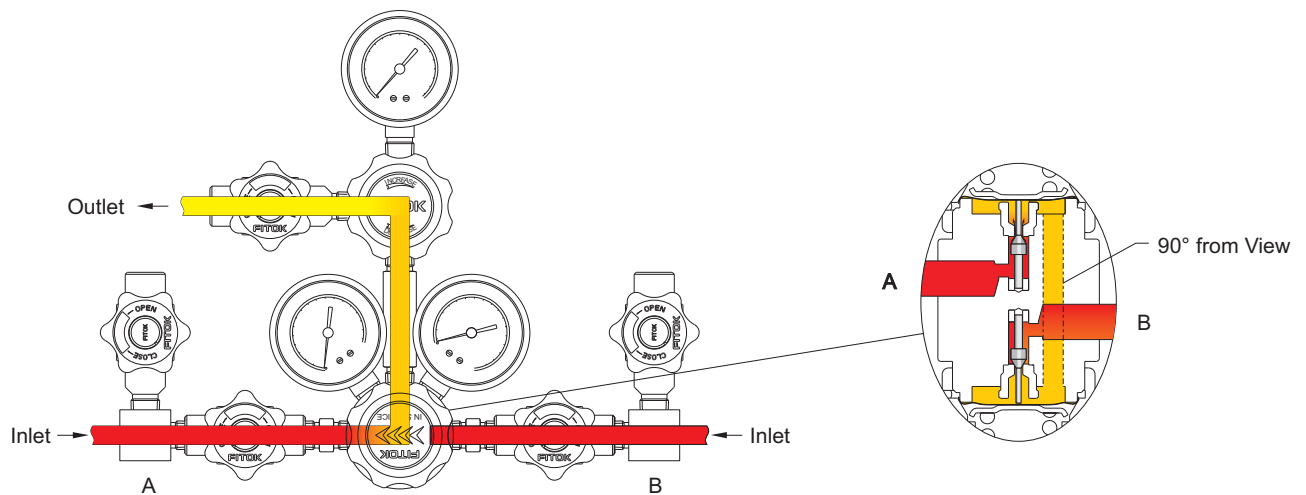

Fig. 2



When gas source of one side is depleted, gas source would automatically change to the other side.

Fig. 3 When "IN SERVICE" arrow is pointing at side B, but gas source of side B is depleted, its outlet pressure shall decrease to be lower than the set pressure of side A. By the force of spring, side A regulator will be opened to begin gas supply.

Before replacing new gas source of side B, the diaphragm valve should be turned off. Otherwise, gas from side A will flow back into side B. Then open the vent valve to exhaust the remaining pressure.

After the replacement, if the "IN SERVICE" arrow still points at side B, side B would be the gas source. If the arrow is turned towards side A, side A would thus be the gas source.

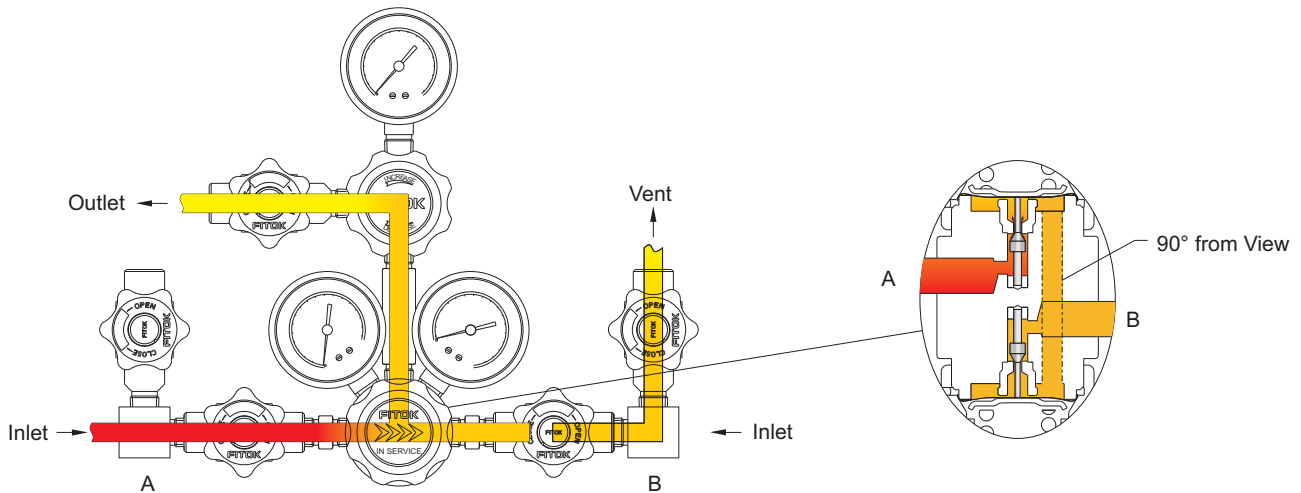
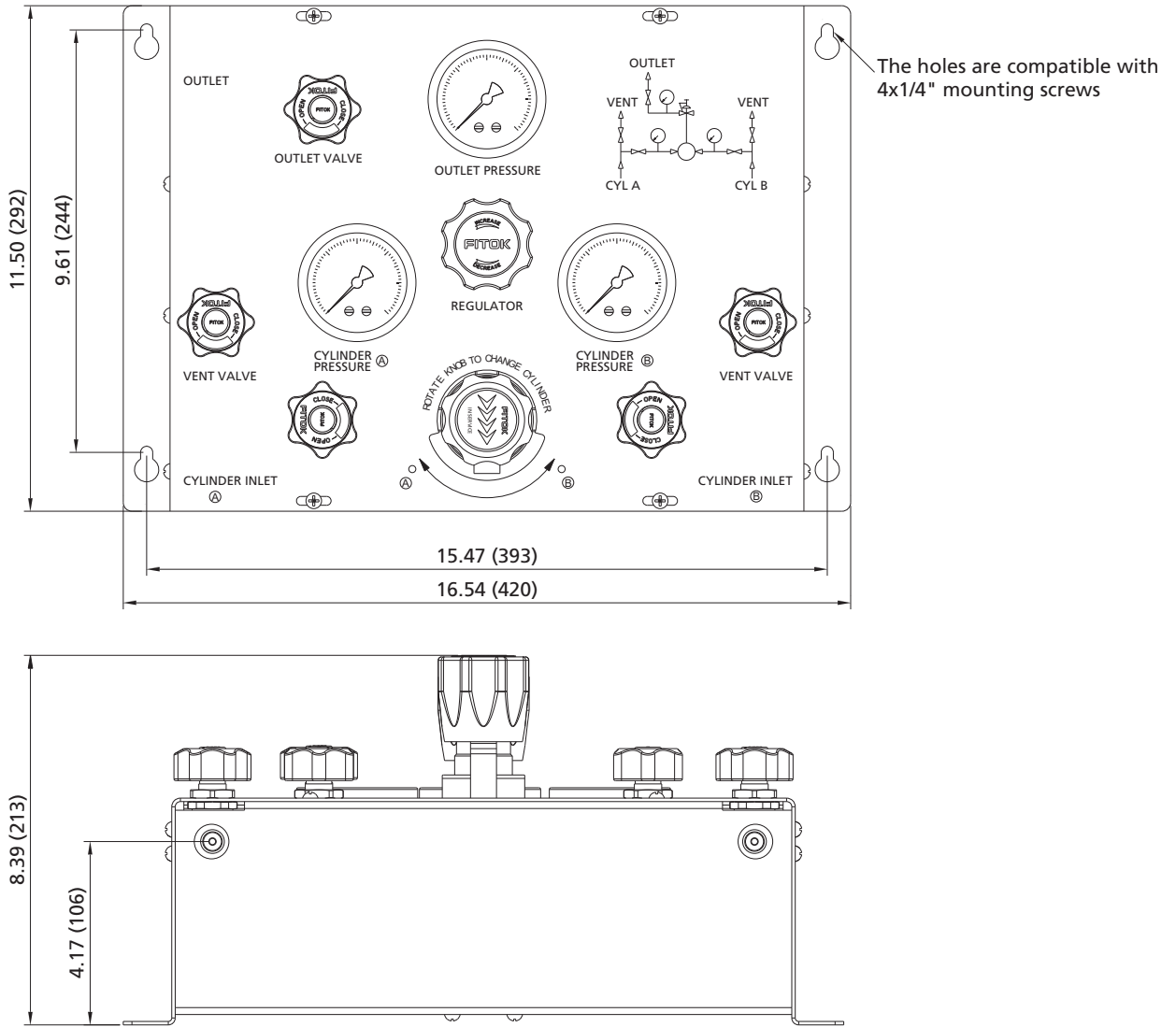

Fig. 3

# Dimensions

Dimensions, in inches (millimeters), are for reference only.



## Part Number Description

FDR - 1T6L - 30 - 25 - B - 10 - 00 - 00

Body Material (Regulator)	Inlet Pressure P1	Outlet Pressure Range P2	Gauge Scale	Inlet A	Inlet B	Outlet
6L 316L SS	30 3000 psig	25 0~25 psig	B psi/bar	00 1/4" Female NPT	Same as Inlet A	Same as Inlet A
SS 316 SS	45 4500 psig	50 0~50 psig	M psi/MPa	01 1/4" Male NPT		
HC Hastelloy C-276		100 0~100 psig		10 1/4" Tube Fitting		
B Brass (Nickel-plated)		150 0~150 psig		11 3/8" Tube Fitting		

Note: Before ordering, please read **Installation Instructions and Cautions** on A-77.

Other connections are available upon request

# Point-of-use Panels

## FPR-1 Series Compact Regulators for Low Pressure

### Features

- ⦿ With a FLR-1 Series Regulator
- ⦿ With metal diaphragm regulators
- ⦿ Shutoff valves with window to visually indicate open and closed states
- ⦿ Anodized Aluminium panel, easy to install
- ⦿ Regulator body of 316L SS or Brass optional
- ⦿ Three configurations available

### Technical Data

- ⦿ Maximum inlet pressure: 1500 psig
- ⦿ Outlet pressure range: 0~25, 0~50, 0~100, 0~250 or 0~500 psig
- ⦿ Material of the main components:
  - Seat: PCTFE (regulator and diaphragm valve)
  - Diaphragm: Hastelloy (regulator), Elgiloy (diaphragm valve)
  - Diaphragm valve body: 316L
  - Filter: 316L
- ⦿ Temperature: -10°F~+150°F (-23°C~+65°C)
- ⦿ Leak rates:
  - Internal:  $\leq 1 \times 10^{-7}$  mbar·l/s helium
  - External:  $\leq 1 \times 10^{-9}$  mbar·l/s helium
- ⦿ Flow coefficient (regulator Cv): 0.14



Model: FPR-1U6L-15-50-11-B-11

### Typical Flow Chart

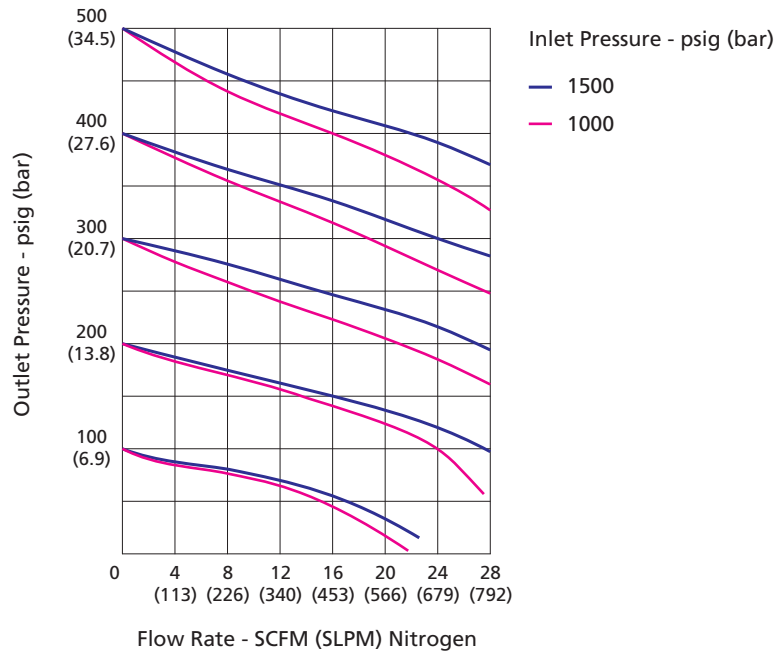

## Dimensions

Dimensions, in inches (millimeters), are for reference only.

### Single-outlet

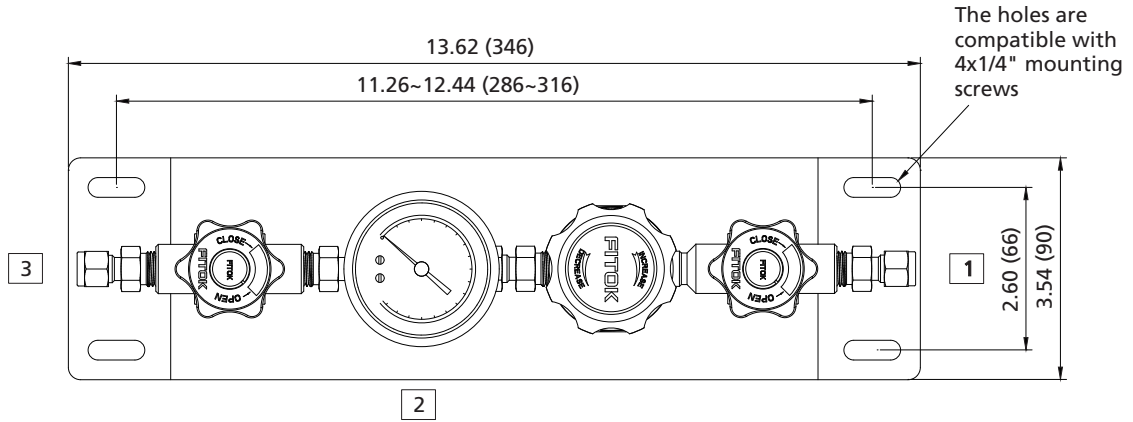

### Dual-outlet

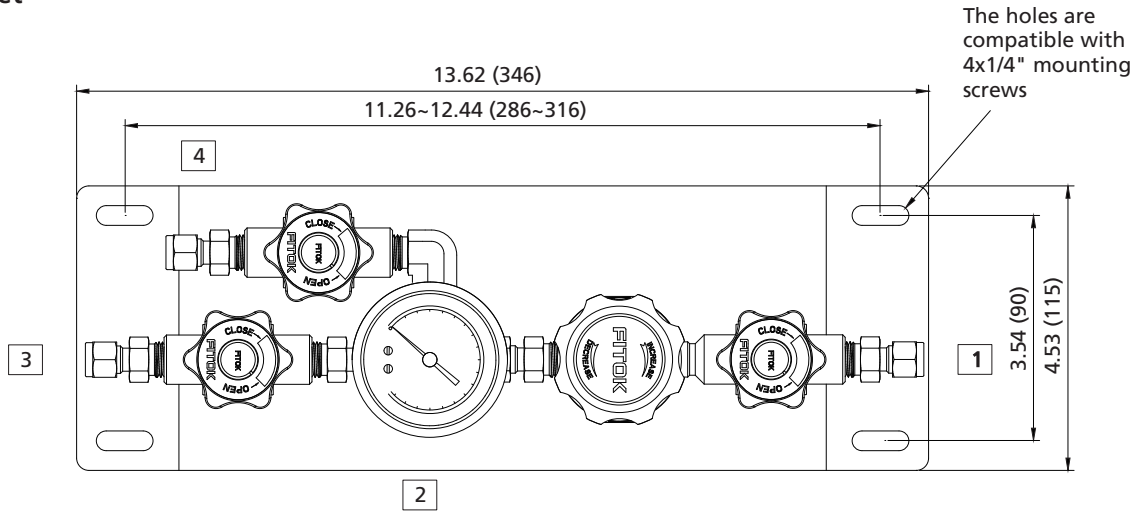

### Triple-outlet

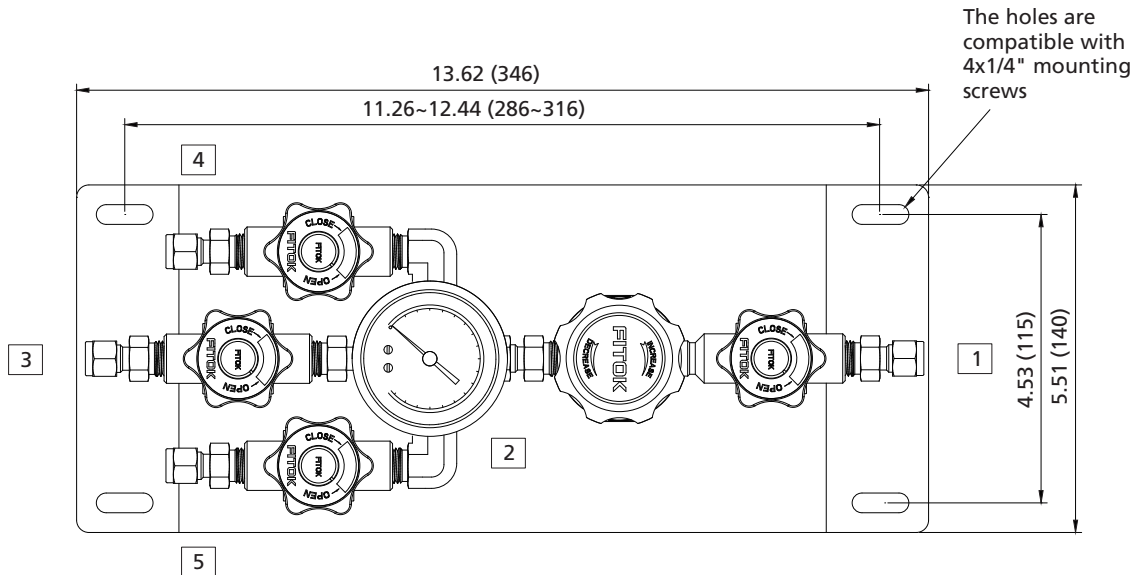

## Components Introduction

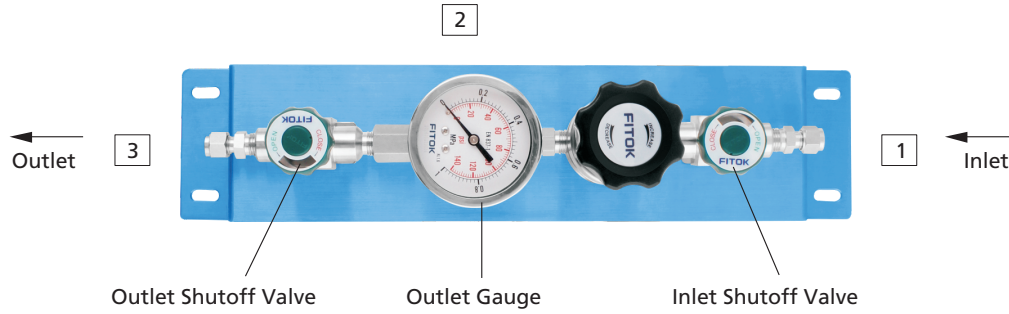

## Part Number Description

FPR - 1C 6L - 15 - 100 - 10 - M - 10 - 00 - 00

Outlet Option		Inlet Pressure P1		Connection 1		Connection 2		Connection 3		Connection 4	
U	Single-outlet	15	1500 psig	00	1/4" Female NPT	B	With Gauge (psi/bar)	00	1/4" Female NPT	Same as Connection 1	
T	Dual-outlet	<b>Outlet Pressure Range P2</b> 25 0~25 psig 50 0~50 psig 100 0~100 psig 250 0~250 psig 500 0~500 psig		01	1/4" Male NPT	M	With Gauge (psi/MPa)	01	1/4" Male NPT	<b>Connection 5</b> Same as Connection 1	
C	Triple-outlet			10	1/4" Tube Fitting	P	Plug	10	1/4" Tube Fitting		
<b>Body Material (Regulator)</b> 6L 316L SS SS 316 SS HC Hastelloy C-276 B Brass (Nickel-plated)				11	3/8" Tube Fitting	00	1/4" Female NPT	11	3/8" Tube Fitting		
				20	6 mm Tube Fitting	Other connections are available upon request		20	6 mm Tube Fitting		
				21	8 mm Tube Fitting			21	8 mm Tube Fitting		
				Other connections are available upon request				Other connections are available upon request			

Note: Before ordering, please read **Installation Instructions and Cautions** on A-77.

Examples of part number:

- a. 2-port type (1 in, 1 out): FPR-1U6L-15-50-11-B-11
- b. 3-port type (1 in, 2 out): FPR-1TSS-15-100-00-B-00-00

# Point-of-use Panels

## FPR-1S Series Sensitive Regulators for Low Pressure

### Features

- ⦿ With a FCR-1S Series Regulator of large diameter metal diaphragm to provide accurate pressure control
- ⦿ Shutoff valves with window to visually indicate open and closed states
- ⦿ Anodized Aluminium panel, easy to install
- ⦿ Three port configurations available

### Technical Data

- ⦿ Maximum inlet pressure: 1500 psig
- ⦿ Outlet pressure range: 0~25, 0~50, 0~100, 0~150 or 0~200 psig
- ⦿ Material of the main components:
  - Seat: PCTFE (regulator and diaphragm valve)
  - Diaphragm: 316L (regulator), Elgiloy (diaphragm valve)
  - Diaphragm valve body: 316L
  - Filter: 316L
- ⦿ Temperature: -10°F~+150°F (-23°C~+65°C)
- ⦿ Leak rates:
  - Internal:  $\leq 1 \times 10^{-7}$  mbar·l/s helium
  - External:  $\leq 1 \times 10^{-9}$  mbar·l/s helium
- ⦿ Flow coefficient (regulator Cv): 0.06



Model: FPR-1SUSS-15-50-10-B-10

### Typical Flow Chart

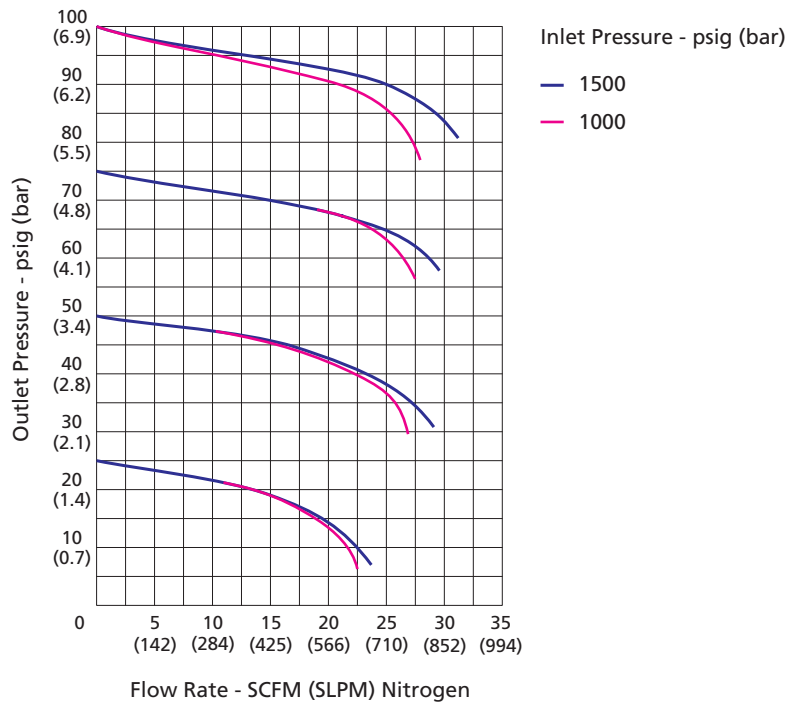

## Dimensions

Dimensions, in inches (millimeters), are for reference only.

### Single-outlet

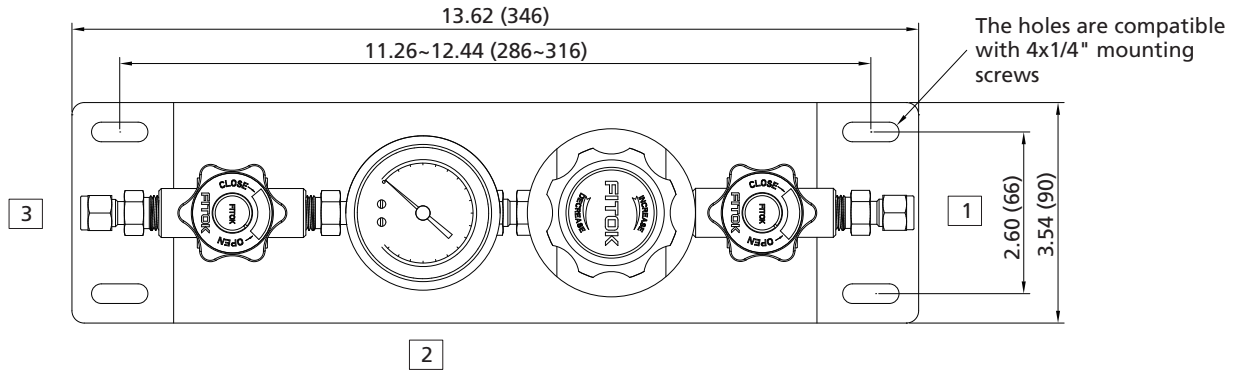

### Dual-outlet

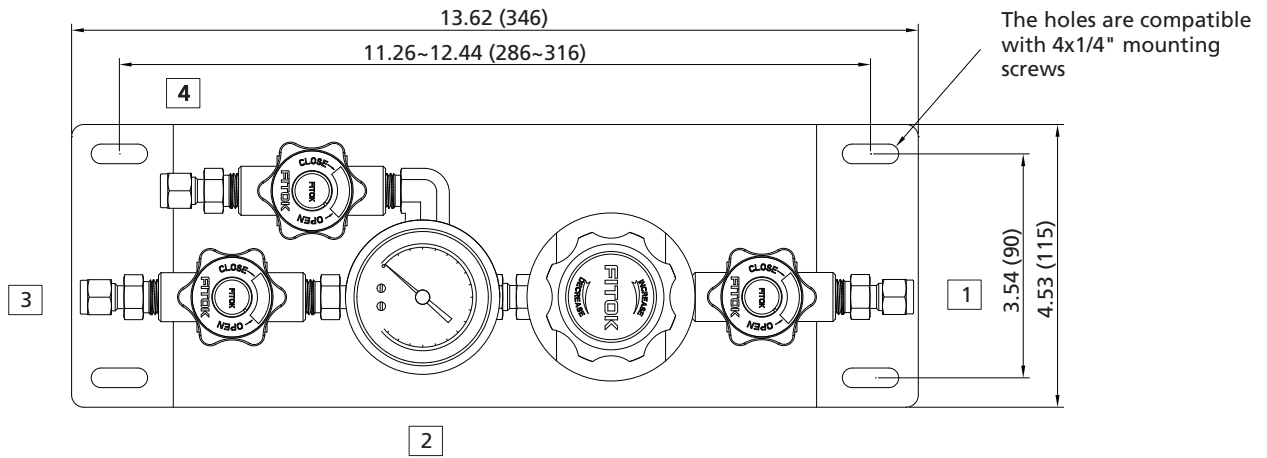

### Triple-outlet

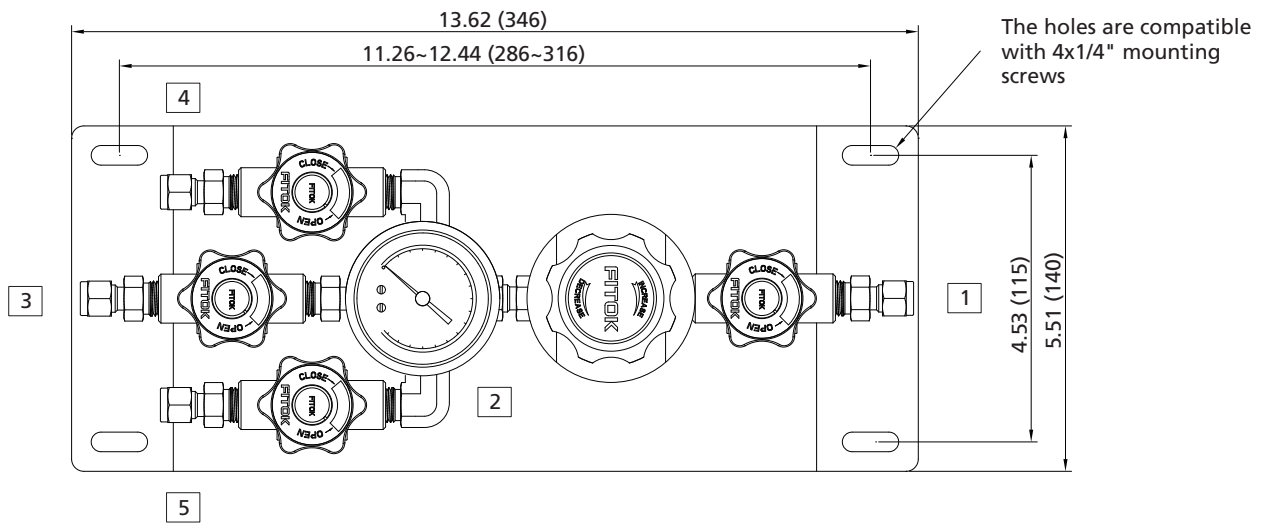

# Components Introduction

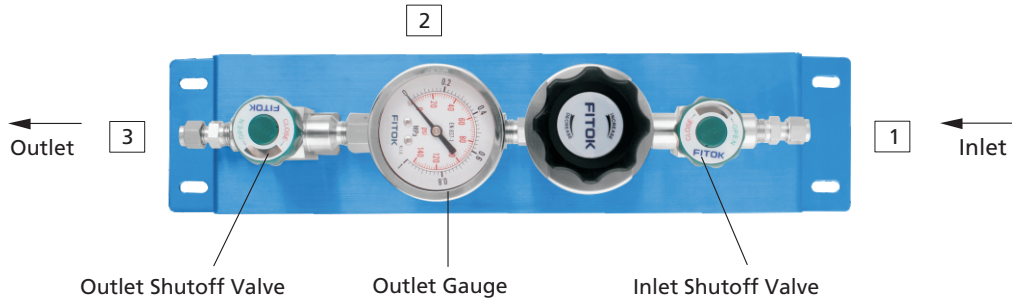

## Part Number Description

FPR - 1SC 6L - 15 - 100 - 10 - M - 10 - 00 - 00

Outlet Option		Inlet Pressure P1		Connection 1		Connection 2		Connection 3		Connection 4	
U	Single-outlet	15	1500 psig	00	1/4" Female NPT	B	With Gauge (psi/bar)	00	1/4" Female NPT	Same as Connection 1	
T	Dual-outlet	Outlet Pressure Range P2		01	1/4" Male NPT	M	With Gauge (psi/MPa)	01	1/4" Male NPT	Connection 5 Same as Connection 1	
C	Triple-outlet			10	1/4" Tube Fitting	P	Plug	10	1/4" Tube Fitting		
Body Material (Regulator)		25	0~25 psig	11	3/8" Tube Fitting	00	1/4" Female NPT	11	3/8" Tube Fitting	Other connections are available upon request	
6L	316L SS	50	0~50 psig	20	6 mm Tube Fitting	Other connections are available upon request		20	6 mm Tube Fitting		
SS	316 SS	100	0~100 psig	21	8 mm Tube Fitting			21	8 mm Tube Fitting		
B	Brass	150	0~150 psig	Other connections are available upon request				Other connections are available upon request			
		200	0~200 psig								

Note: Before ordering, please read **Installation Instructions and Cautions** on A-77.

Examples of part number:

a. 2-port type (1 in, 1 out): FPR-1SU6L-15-25-00-B-20

b. 3-port type (1 in, 2 out): FPR-1STB-15-200-10-M-10-10



# Back Pressure Regulators

## BPR-1 Series Back Pressure Diaphragm Regulators

### Features

- ⦿ Metal-to-metal seal with convoluted diaphragm
- ⦿ Close pressure differential between crack and reseal
- ⦿ Panel mounting available

### Technical Data

- ⦿ Maximum control pressure: 250 psig
- ⦿ Pressure control range: 0~25, 0~50, 0~100 or 0~250 psig
- ⦿ Material of the main components:
  - Seat: PCTFE
  - Diaphragm: Hastelloy
- ⦿ Temperature: -40°F~+140°F (-40°C~+60°C)
- ⦿ Leak rates:
  - Internal: Bubble-tight
  - External:  $\leq 1 \times 10^{-9}$  mbar · l/s helium
- ⦿ Flow coefficient (Cv): 0.3
- ⦿ Weight:  $\approx 1.98$  lbs (0.9 kg)
- ⦿ Body ports: 1/4" female NPT for inlet, outlet and gauge



Model: BPR-16L-250-00-00-Z

### Typical Flow Chart

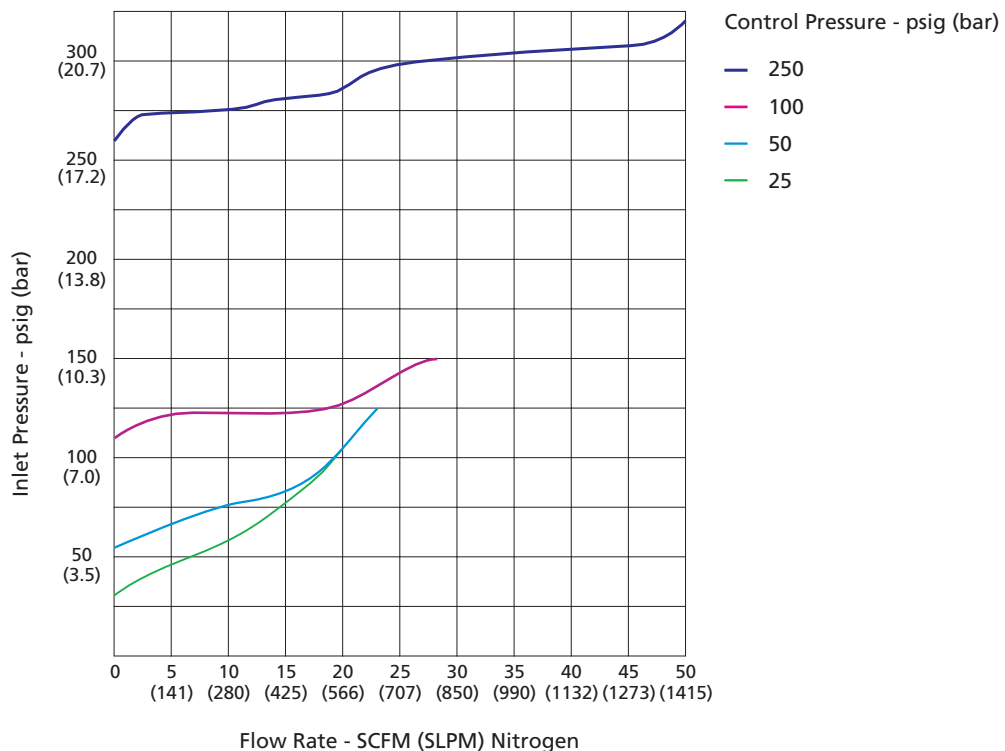

## Dimensions

Dimensions, in inches (millimeters), are for reference only.

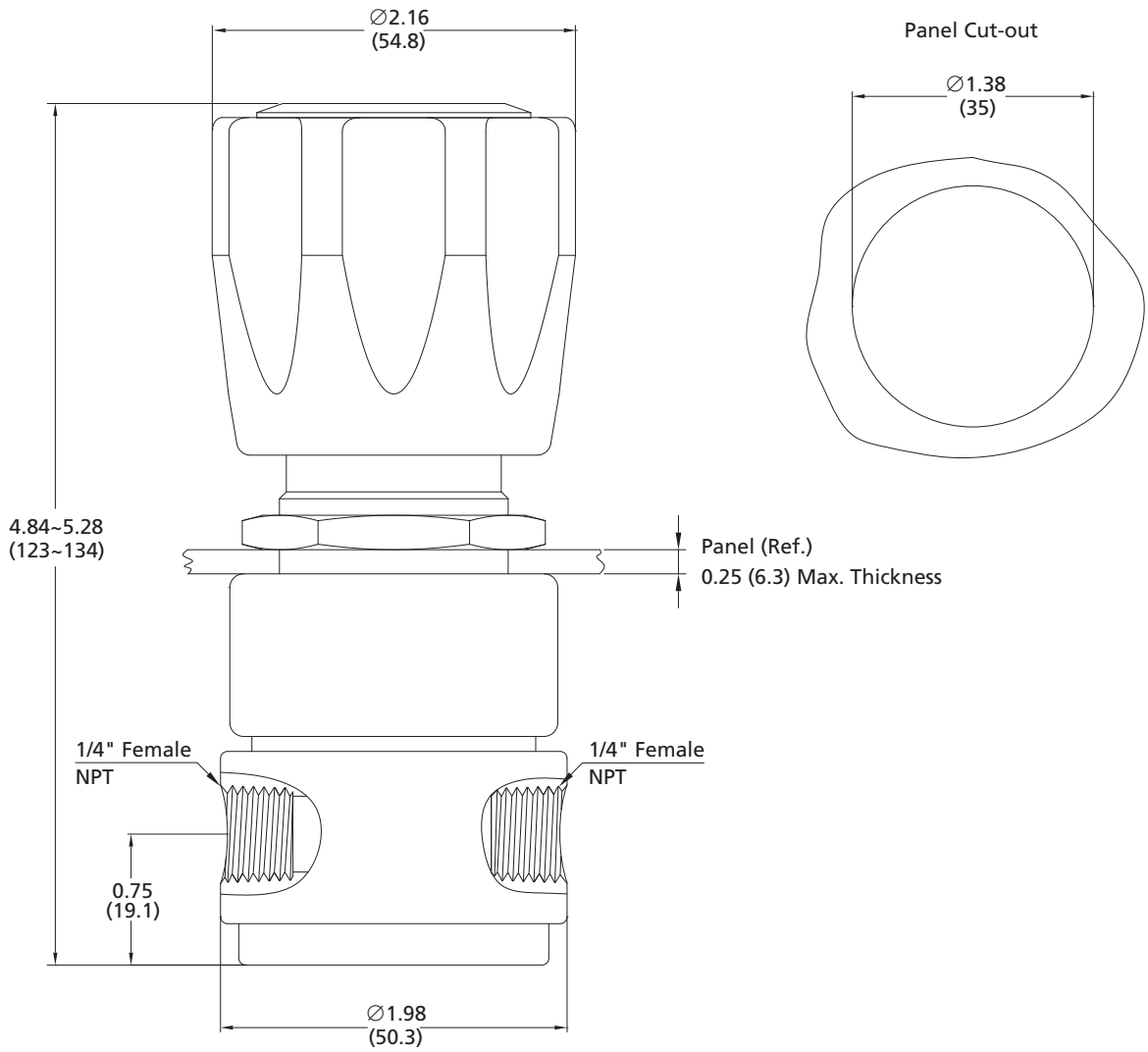

Bottom View

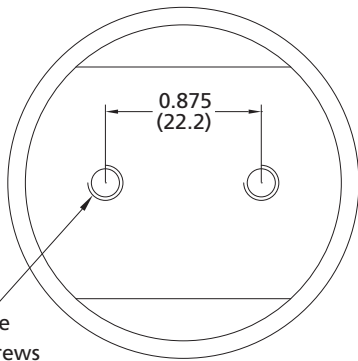

2xM5x0.8-6H thread  
The holes are compatible with 10-32 mounting screws

Bottom Panel Cut-out

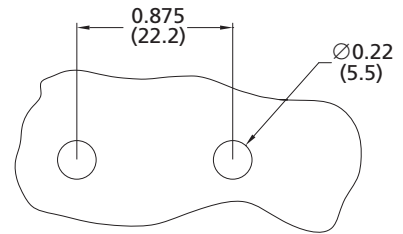

## Port Configurations

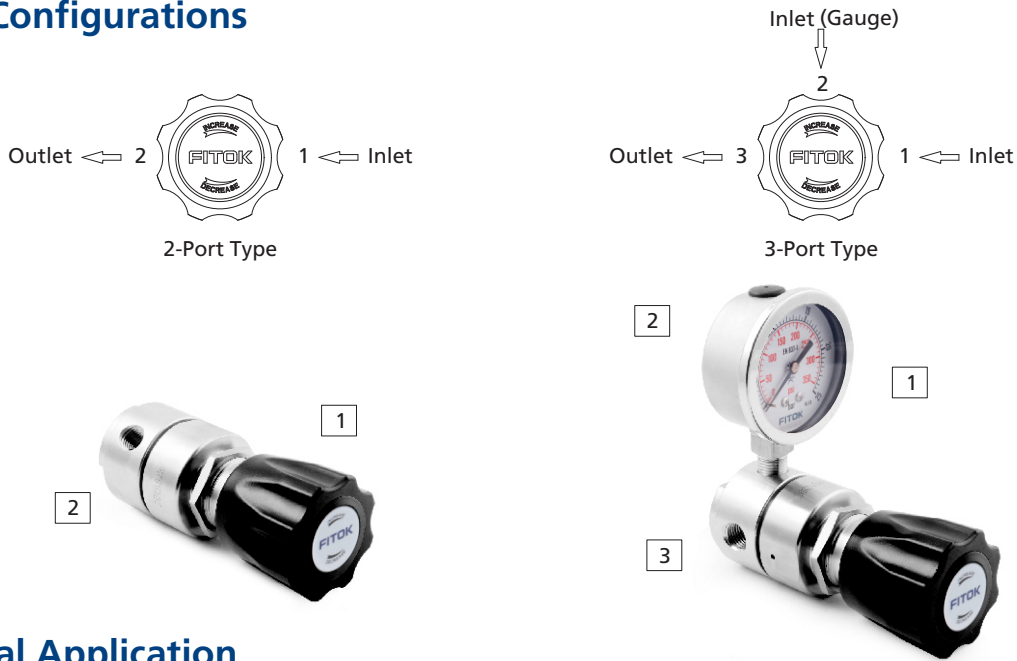

## Typical Application

When the system pressure is lower than the set pressure, the diaphragm obstructs the flow by the force of spring. When the system pressure is higher than the set pressure, the diaphragm compresses the inner spring to connect the flow so as to allow the fluid to pass through the back pressure regulator to keep the pressure of the Storage Vessel stable.

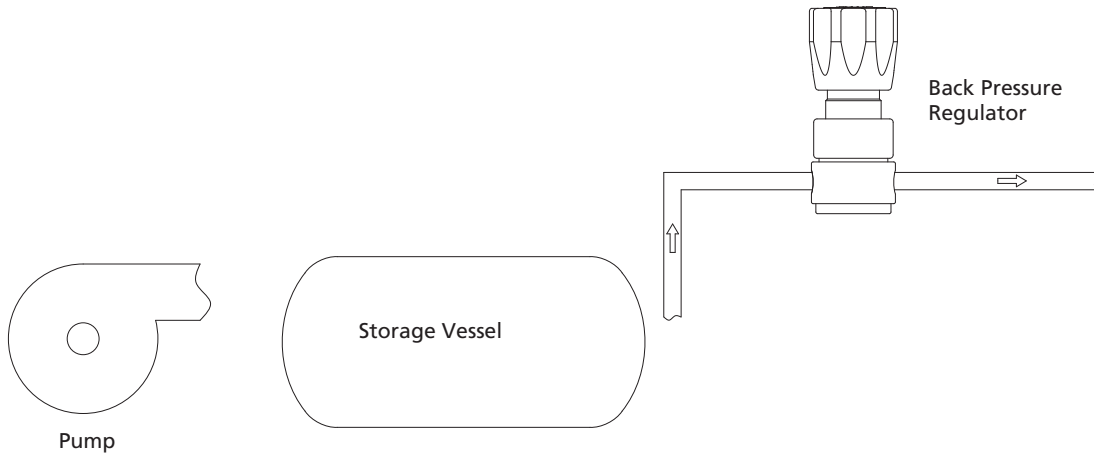

## Part Number Description

BPR - 16L - 100 - 10 - M - 11 - Z

Body Material	Control Pressure Range P	Connection 1	Connection 2	Connection 3	Installation Type
6L 316L SS	25 0~25 psig	00 1/4" Female NPT	B With Gauge (psi/bar)	Same as Connection 1	Not Required
SS 316 SS	50 0~50 psig	01 1/4" Male NPT	M With Gauge (psi/MPa)		Z Installed with One Panel Nut
B Brass (Nickel-plated)	100 0~100 psig	10 1/4" Tube Fitting	P Plug	Same as Connection 1	N Installed with Screws at the Bottom
	250 0~250 psig	11 3/8" Tube Fitting	00 1/4" Female NPT		
		20 6 mm Tube Fitting	01 1/4" Male NPT		
		21 8 mm Tube Fitting	10 1/4" Tube Fitting		
		Other connections are available upon request	Other connections are available upon request		

Note: Before ordering, please read **Installation Instructions and Cautions** on A-77.  
 Examples of part number:  
 a. 2-port type (1 in, 1 out): BPR-16L-25-00-00

# Back Pressure Regulators

## BPR-2 Series Back Pressure Piston Regulators

### Features

- ⦿ Durable piston-sensed design
- ⦿ Bubble-tight shutoff at all reseating pressure
- ⦿ Low operating torque
- ⦿ Panel mounting available
- ⦿ With special cleaning and packaging, applicable to oxygen-enriched environments

### Technical Data

- ⦿ Maximum control pressure: 1000 psig
- ⦿ Pressure control range: 10~300, 10~500 or 10~1000 psig
- ⦿ Material of the main components:
  - Seat: PCTFE
  - Piston: 316L
  - O-rings: Viton or Kalrez
- ⦿ Temperature: -15°F~+165°F (-26°C~+74°C)
- ⦿ Leak rates:
  - Internal: Bubble-tight
  - External: Bubble-tight
- ⦿ Flow coefficient (Cv): 0.3
- ⦿ Weight: ≈1.98 lbs (0.9 kg)
- ⦿ Body ports: 1/4" female NPT for inlet, outlet and gauge



Model: BPR-26LZ-300-00-00-Z

### Typical Flow Chart

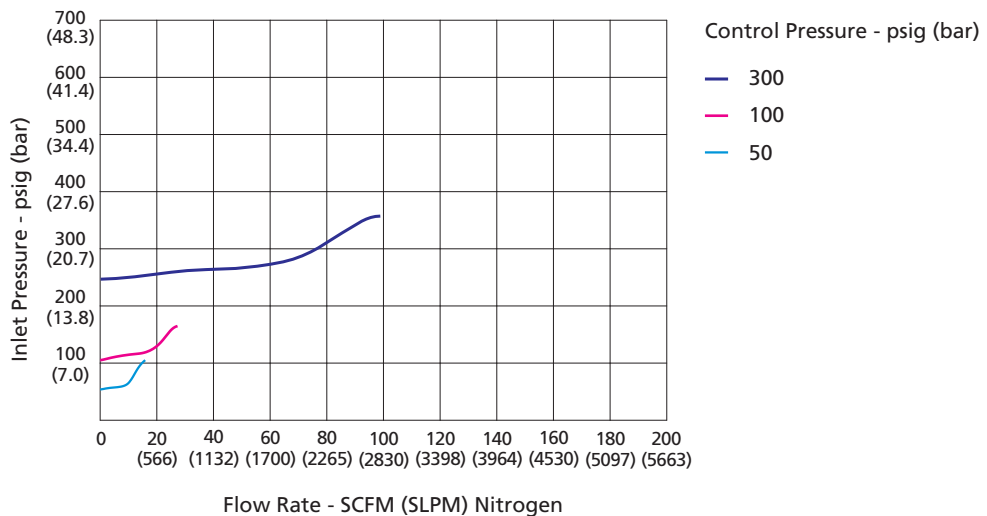

## Dimensions

Dimensions, in inches (millimeters), are for reference only.

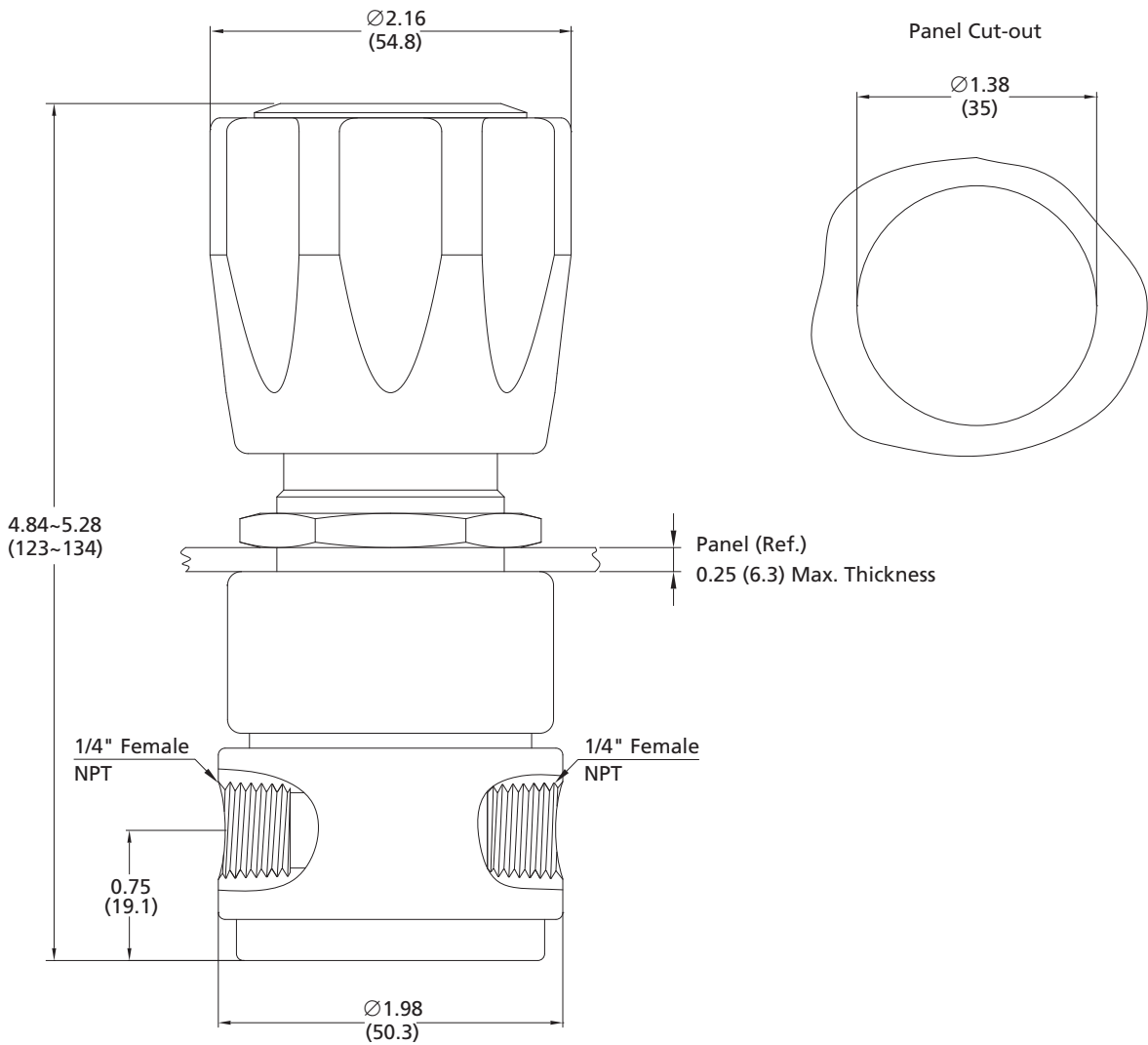

Bottom View

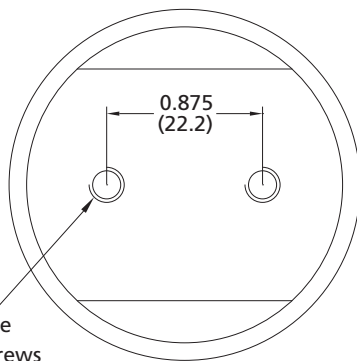

$2 \times M5 \times 0.8-6H$  thread  
The holes are compatible with 10-32 mounting screws

Bottom Panel Cut-out

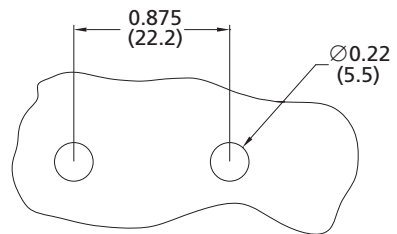

# Port Configurations

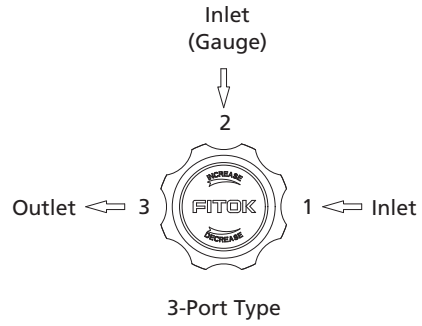
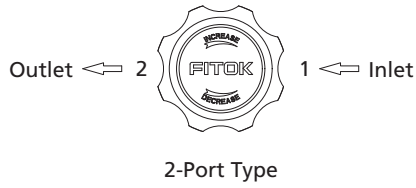

## Typical Application

BPR-2 Series Back Pressure Regulators maintain the required pipeline pressure to ensure the Pump to output fluid stably when system pressure fluctuates.

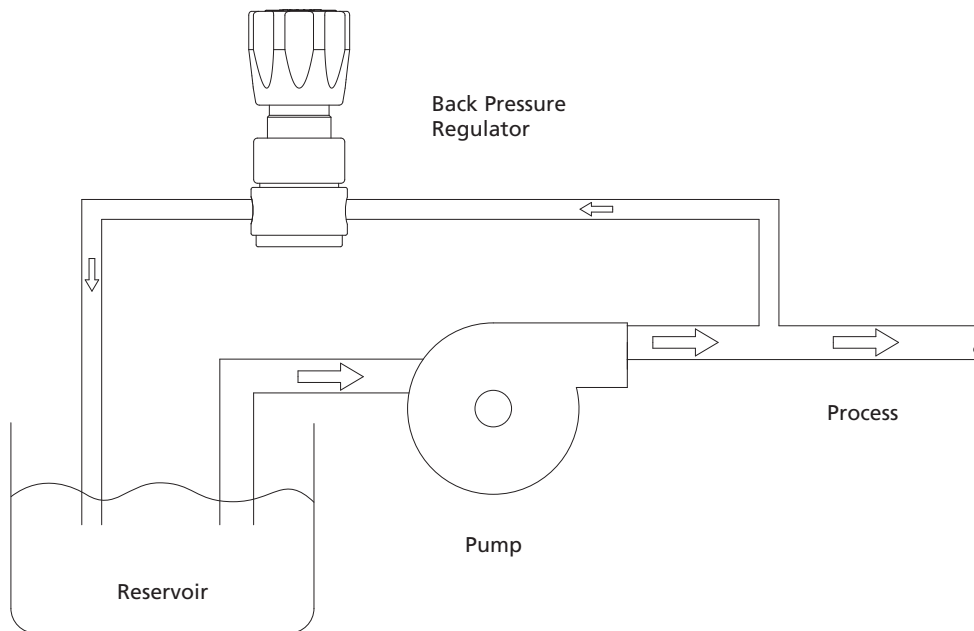

## Part Number Description

BPR – 26L Z – 300 – 10 – M – 11 – Z

Body Material		Control Pressure Range P		Connection 1		Connection 2		Connection 3		Installation Type	
6L	316L SS	300	10~300 psig	00	1/4" Female NPT	B	With Gauge (psi/bar)	Same as Connection 1			Not Required
SS	316 SS	500	10~500 psig	01	1/4" Male NPT	M	With Gauge (psi/MPa)			Z	Installed with One Panel Nut
B	Brass (Nickel-plated)	1000	10~1000 psig	10	1/4" Tube Fitting	P	Plug			N	Installed with Screws at the Bottom
				11	3/8" Tube Fitting	00	1/4" Female NPT				
				20	6 mm Tube Fitting	01	1/4" Male NPT				
				21	8 mm Tube Fitting	10	1/4" Tube Fitting				
				Other connections are available upon request		Other connections are available upon request					

O-ring Material	
	Viton
Z	Kalrez

Note: Before ordering, please read **Installation Instructions and Cautions** on A-77.

Examples of part number:

- a. 2-port type (1 in, 1 out): BPR-2SS-500-00-00

# Back Pressure Regulators

## BPR-3 Series Back Pressure Piston Regulators

### Features

- ⦿ Control of back-pressure up to 10000 psig for gas or liquid application
- ⦿ Safe and reliable piston sensing
- ⦿ 7 pressure control ranges
- ⦿ Panel mounting available
- ⦿ Special cleaning and packaging available for application in oxygen-enriched environments

### Technical Data

- ⦿ Maximum control pressure:  
Stainless steel: 10000 psig  
Brass: 6000 psig
- ⦿ Pressure control ranges: 5~500, 5~800, 10~1500, 15~2500, 25~4000, 50~6000, 200~10000 psig
- ⦿ Material of the main components:  
Body: 316 SS or brass  
Seat: PEEK  
Piston: 316L  
O-rings: Viton or Kalrez
- ⦿ Temperature: -15°F~+165°F (-26°C~+74°C)
- ⦿ Leak rates:  
Internal: Bubble-tight  
External: Bubble-tight
- ⦿ Flow coefficient (Cv): 0.25
- ⦿ Weight(regulator): ≈5.7 lbs (2.6 Kg)
- ⦿ Body ports: 1/4" female NPT for inlet, outlet, and gauge



Model: BPR-3SS-40-00-00-Z

### Typical Flow Chart

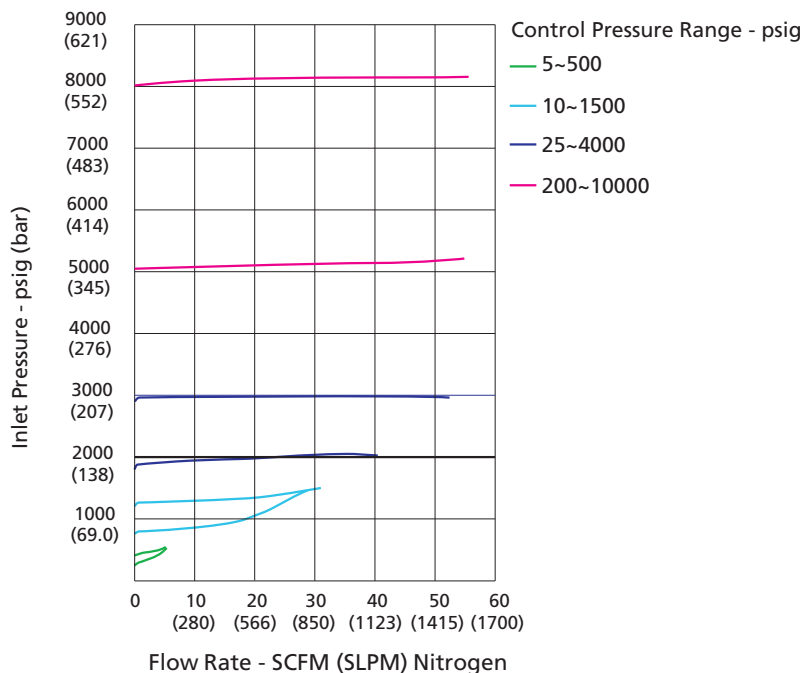



## Dimensions

Dimensions, in inches (millimeters), are for reference only.

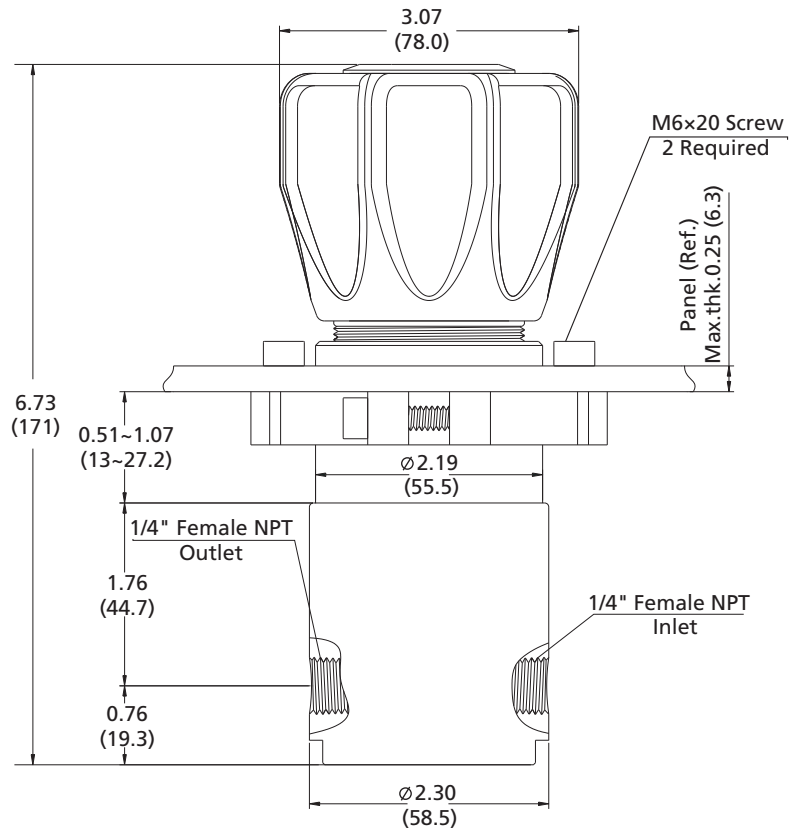

Bottom View

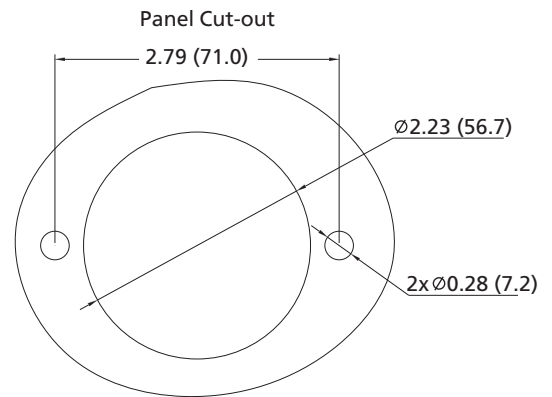
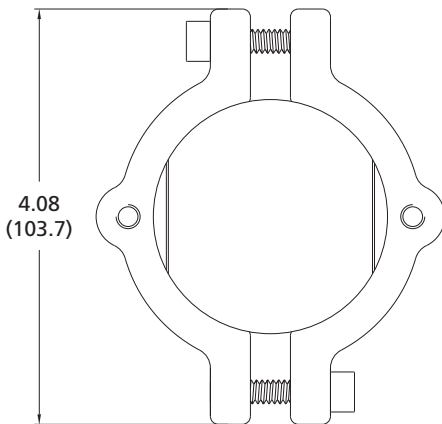

# Port Configurations

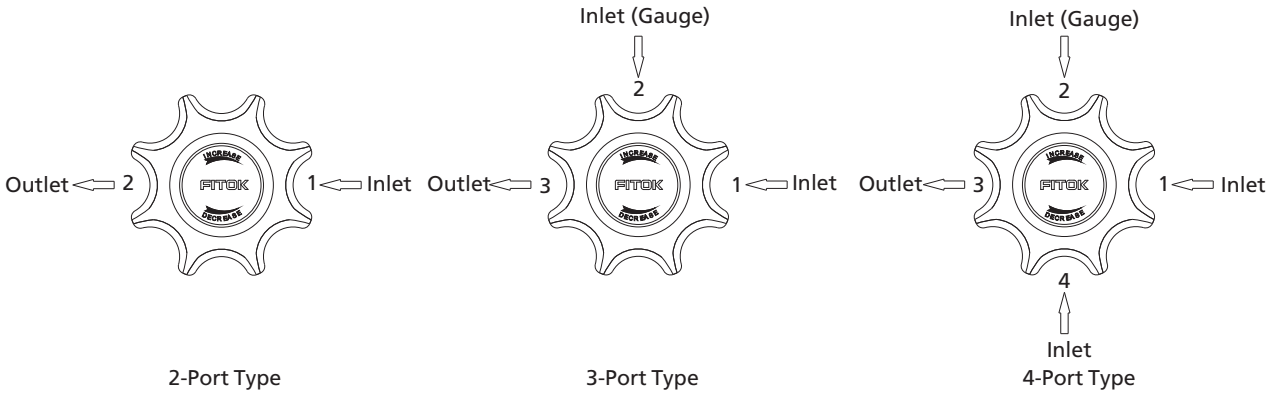

## Part Number Description

**BPR-3B**    **Z** - **15** - **00** - **B** - **00** - **00** - **Z** - **F2**

Body Material	Pressure Control Range P	Connection 1	Connection 2	Connection 3	Connection 4	Panel Mount	Product Technology Grade
SS 316 SS	5 5~500 psig	00 1/4" Female NPT	B With Gauge (psi/bar)	Same as Connection 1	Same as Connection 1	Without	General Purpose
6L 316L SS	8 5~800 psig	01 1/4" Male NPT	M With Gauge (psi/MPa)			z With	
B Brass (Max. Control Pressure 6000 psig)	15 10~1500 psig	10 1/4" Tube Fitting	P Plug				
	25 15~2500 psig	11 3/8" Tube Fitting	00 1/4" Female NPT				
	40 25~4000 psig	20 6 mm Tube Fitting	01 1/4" Male NPT				
O-ring Material	60 50~6000 psig	21 8 mm Tube Fitting	10 1/4" Tube Fitting				F2 Special Cleaning and Packaging
	100 200~10000 psig	Other connections are available upon request	11 3/8" Tube Fitting				
Viton			20 6 mm Tube Fitting				
Z Kalrez			21 8 mm Tube Fitting				
			Other connections are available upon request				

Note: Before ordering, please read **Installation Instructions and Cautions** on A-77.

Examples of part number:

- a. 2-Port type (1 in, 1 out): BPR-3B-25-00-00
- b. 3-Port type (2 in, 1 out): BPR-3B-40-00-M-00
- c. 4-Port type (3 in, 1 out): BPR-3B-60-00-M-00-00

# Purge Assemblies

## FPV-1 Series

### Technical Data

- ⦿ Maximum working pressure: 4500 psig
- ⦿ Material of the main components:  
 Seat: PCTFE (diaphragm valve)  
 Diaphragm: Elgiloy (diaphragm valve)
- ⦿ Temperature: -10°F~+150°F (-23°C~+65°C)
- ⦿ Leak rates:  
 Internal:  $\leq 1 \times 10^{-9}$  mbar·l/s helium  
 External:  $\leq 1 \times 10^{-9}$  mbar·l/s helium
- ⦿ Minimum orifice:  $\Phi 0.13"$  (3.2 mm)

### Product Types

- ⦿ Straight Purge Assemblies  
 Consisting of a diaphragm valve and a check valve (see Fig. 1-1).  
 Connecting the auxiliary inlet port (see Fig. 1-2) of the regulator or in between the regulator and the cylinder (see Fig. 1-3) to allow the corrosive or toxic gas to be vented through to a safe location.

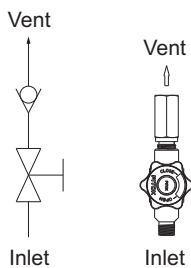

Fig. 1-1

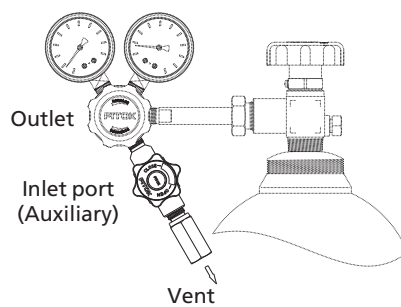

Fig. 1-2

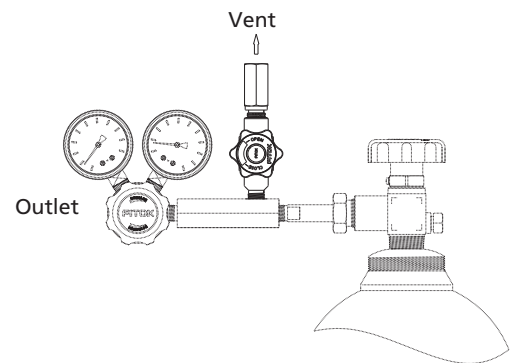

Fig. 1-3

- ⦿ Tee Purge Assemblies  
 Consisting of a diaphragm valve, check valve, tee, and cylinder connections (see Fig. 2-1).  
 Connecting the cylinder with the regulator. Before installing a new cylinder, open the diaphragm valve, and the remaining gas is vented safely; or after a new cylinder is installed, close the regulator and open the diaphragm valve, enabling the process gas inside the cylinder to purge the atmospheric contamination between the cylinder and the regulator (see Fig. 2-2).



Fig. 2-1

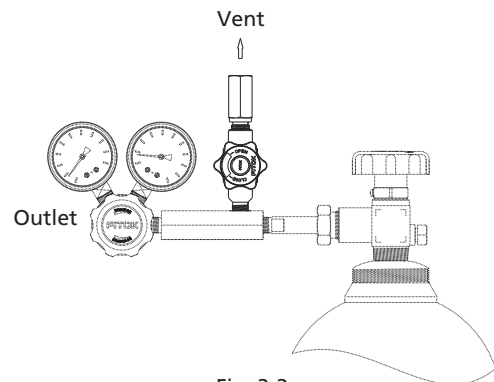

Fig. 2-2

◎ Cross Purge Assemblies

Consisting of a tee purge assembly and two additional diaphragm valves (see Fig. 3-1).

Except for process gas, purging is also made possible with inert gas from outside (see Fig. 3-2). The steps are as follows: Before installing a new cylinder, close the diaphragm valve beside the regulator, and open the shutoff diaphragm valve on the vent line to release the residual pressure.

After installing a new cylinder, open the diaphragm valve on the bottom, allowing the inert gas from outside to purge the atmospheric contaminations between the cylinder and the diaphragm valve.

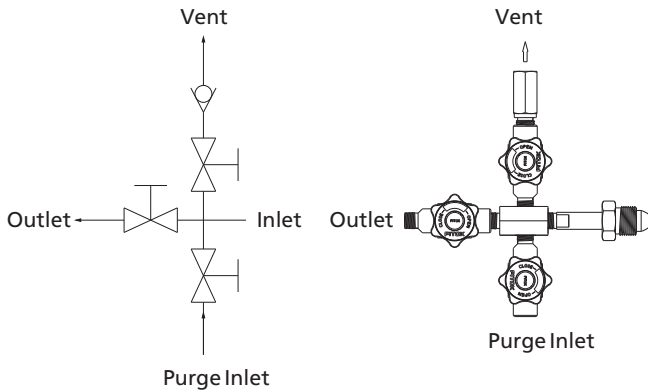

Fig. 3-1

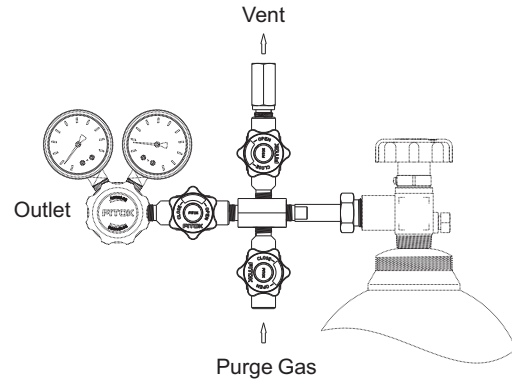

Fig. 3-2

### Part Number Description

FPV – 1C      6L      –      DIN1      –      00      –      00      –      00

Product Type		Body Material		Inlet Port		Vent Port		Outlet Port		Purge Inlet	
S	Straight Purge Assemblies	6L	316L SS	00	1/4" Female NPT	00	1/4" Female NPT	Same as Same as Vent Port		Same as Same as Vent Port	
T	Tee Purge Assemblies	SS	316 SS	01	1/4" Male NPT	01	1/4" Male NPT				
C	Cross Purge Assemblies			C_ _ _	CGA Number (USA)	10	1/4" Tube Fitting				
				DIN_	DIN Number (Germany)	20	6 mm Tube Fitting				
					Refer to page B-28 for cylinder connections based on specific gas type. Cylinder connections compliant to other standards are available upon request. Please contact FITOK Group for details.	21	8 mm Tube Fitting				
							Other connections are available upon request				



# Ball Valves

## BO Series

### Features

- One-piece body and one-piece ball stem
- No dead zone, such as in the area between the ball and valve chamber
- In-line inspection and repair with top entry design
- Thermal cycle performance improved and wear compensated by live-loaded design
- Multiple connections available
- Pneumatic and electric actuators available



### Technical Data

- Maximum working pressure: 3000 psig (207 bar)
- Temperature: -65°F to 300°F (-54°C to 148°C)
- Seat material: PTFE

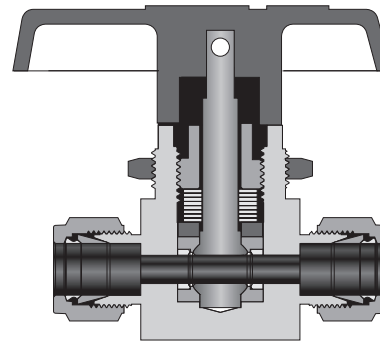

### Part Number Description

<b>BO</b>		<b>6L</b>		<b>- NS</b>		<b>4 - FNS</b>		<b>4 - H03</b>		<b>- U A</b>		<b>- F2</b>	
<b>Body Material</b>		<b>Connection 1 Type</b>		<b>Connection 2 Type</b>		<b>Connection 2 Size</b>		<b>Orifice Size</b>		<b>Flow Pattern</b>		<b>Technology Grade</b>	
<b>6L</b>	316L SS	<b>FNS</b>	Female NPT	Same as Connection 1		Specify in the same way as inlet type		<b>02</b>	0.09" (2.4 mm)	Straight		General Purpose	
<b>SS</b>	316 SS	<b>NS</b>	Male NPT	Specify in the same way as inlet type		Specify in the same way as inlet size		<b>03</b>	0.13" (3.2 mm)	<b>A</b> Angle		<b>F2</b> Special Cleaning and Packaging	
<b>B</b>	Brass	<b>FR</b>	Male FR Fitting	Specify in the same way as inlet size				<b>05</b>	0.19" (4.8 mm)	<b>Handle</b>			
		<b>FL</b>	Fractional Tube Fitting					<b>07</b>	0.28" (7.1 mm)			Black Nylon	
		<b>ML</b>	Metric Tube Fitting					<b>10</b>	0.41" (10.3 mm)	Red Nylon			
		<b>Connection 1 Size</b>						<b>Seat Material</b>		Green Nylon			
		<b>4</b>		1/4"				PTFE		Blue Nylon			
		<b>6</b>		6 mm or 3/8"				<b>H</b>		Black Aluminium			
		<b>8</b>		8 mm or 1/2"				<b>A</b>					
								UHMWPE					
								PFA					

# Cylinder Connections



CGA DISS Series

B-16

CGA Series

B-20

DIN Series

B-27

Gas Connection Assignment Table

B-28

## Features

- ⦿ 100% visual inspection of critical surfaces
- ⦿ Diverse material and configurations available
- ⦿ Silver-plated nut threads to reduce installation torque
- ⦿ Every fitting marked with size, material and heat number
- ⦿ Cleaned and packaged for Oxygen and Ultra High Purity Service available
- ⦿ Customized solutions available

## Material

Series	Component	Material	Designator
CGA DISS	Nipples	316L SS	6L
	Nuts	304 SS	S4
	Gaskets	Nickel 200	NI
		PCTFE	K
		Aluminum	AL
	Plugs	316L SS	6L
	Adapters	316L SS	6L
Caps	316L SS	6L	
CGA DIN	Nipples	316L SS	6L
	Nuts	304 SS	S4
	Gaskets	PTFE	T
		PCTFE	K
	Plugs, Caps	316L SS	6L
Adapters	316L SS	6L	

**Notes:**

1. Nickel gasket heat treated; surface hardness < HB 100
2. 316L SS in compliance with SEMI F20

## Ordering information

- ⦿ Add material designator as a prefix to the basic ordering number to get the complete ordering number.  
Example: 6L-C634-L-FR4
- ⦿ CGA, DIN Series  
PTFE is standard material for gasket. If PCTFE is required, please add a suffix of "-k" to the ordering number.  
Example: 6L-C350-NS4-K
- ⦿ CGA DISS Series  
Nickel is standard material for gasket. If PCTFE is required, please add a suffix of "-k" to the ordering number.  
Example: 6L-C632-FR4-K

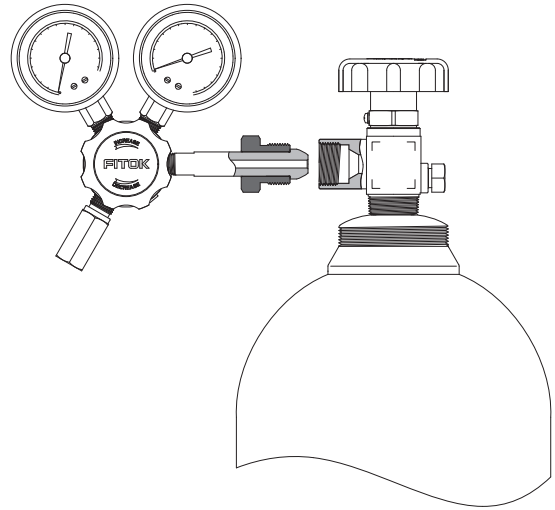



# CGA DISS Series

- ⦿ Non-rotating design
- ⦿ For nipples with TB or FR connections, inner surface electropolished to an average of Ra 9 µm. (0.23 µm); Ra 16 µm. (0.4 µm) for nipples with NPT connections
- ⦿ Nipples with TB or FR connections cleaned for Ultra High Purity Service and packaged in a Class 100 clean room; Nipples with NPT connections packaged and cleaned for Oxygen service
- ⦿ Maximum allowable leak rate:  $1 \times 10^{-9}$  mbar·l/s

## Cylinder Connections (Including Nipples, Nuts and Gaskets)

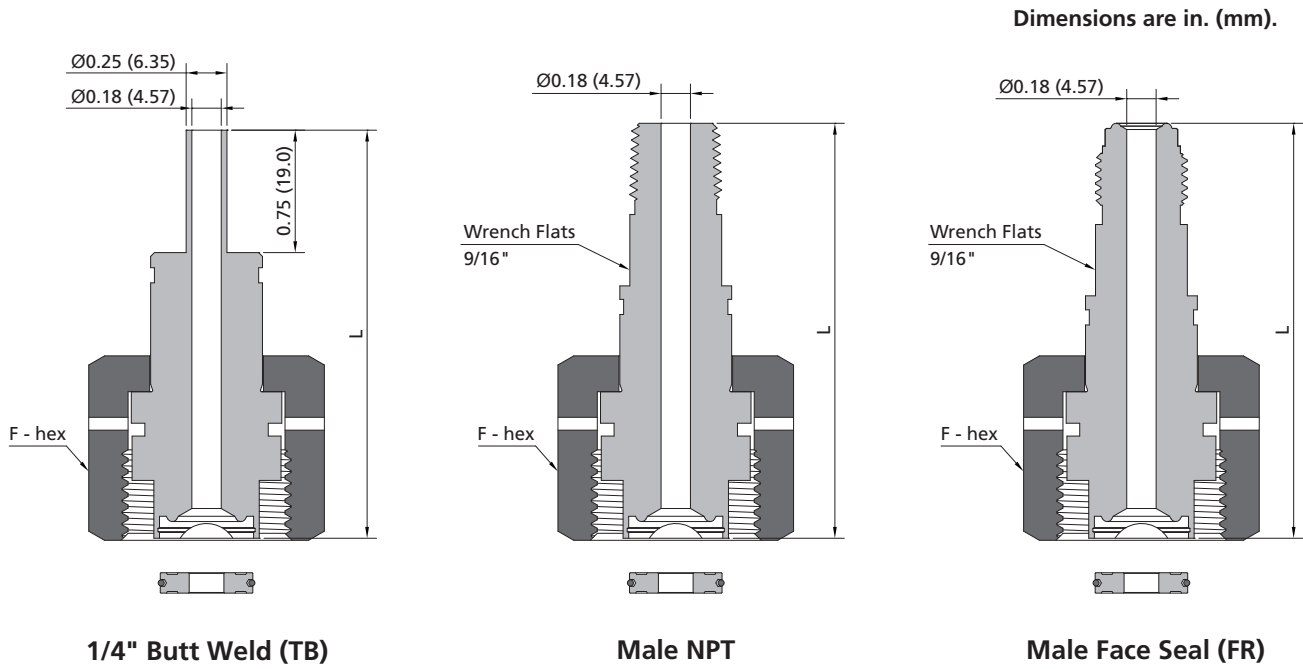

CGA Number	End Connection	Assembly Basic Ordering Number	Nipple Basic Ordering Number	Nut Basic Ordering Number	Gasket Basic Ordering Number	Dimensions, in. (mm)	
						L	F
632	1/4" TB	-C632-TB4	-C632-L-TB4	-C630-N	-C630-GT	2.5 (63.5)	1 1/4 (31.8)
	1/4" FR	-C632-FR4	-C632-L-FR4			3 (76.2)	1 1/4 (31.8)
	1/4" NPT	-C632-NS4	-C632-L-NS4			3 (76.2)	1 1/4 (31.8)
634	1/4" TB	-C634-TB4	-C634-L-TB4	-C630-N	-C630-GT	2.5 (63.5)	1 1/4 (31.8)
	1/4" FR	-C634-FR4	-C634-L-FR4			3 (76.2)	1 1/4 (31.8)
	1/4" NPT	-C634-NS4	-C634-L-NS4			3 (76.2)	1 1/4 (31.8)
636	1/4" TB	-C636-TB4	-C636-L-TB4	-C630-N	-C630-GT	2.5 (63.5)	1 1/4 (31.8)
	1/4" FR	-C636-FR4	-C636-L-FR4			3 (76.2)	1 1/4 (31.8)
	1/4" NPT	-C636-NS4	-C636-L-NS4			3 (76.2)	1 1/4 (31.8)
638	1/4" TB	-C638-TB4	-C638-L-TB4	-C630-N	-C630-GT	2.5 (63.5)	1 1/4 (31.8)
	1/4" FR	-C638-FR4	-C638-L-FR4			3 (76.2)	1 1/4 (31.8)
	1/4" NPT	-C638-NS4	-C638-L-NS4			3 (76.2)	1 1/4 (31.8)

CGA Number	End Connection	Assembly Basic Ordering Number	Nipple Basic Ordering Number	Nut Basic Ordering Number	Gasket Basic Ordering Number	Dimensions, in. (mm)	
						L	F
640	1/4" TB	-C640-TB4	-C640-L-TB4	-C630-N	-C630-GT	2.5 (63.5)	1 1/4 (31.8)
	1/4" FR	-C640-FR4	-C640-L-FR4			3 (76.2)	1 1/4 (31.8)
	1/4" NPT	-C640-NS4	-C640-L-NS4			3 (76.2)	1 1/4 (31.8)
642	1/4" TB	-C642-TB4	-C642-L-TB4	-C630-N	-C630-GT	2.5 (63.5)	1 1/4 (31.8)
	1/4" FR	-C642-FR4	-C642-L-FR4			3 (76.2)	1 1/4 (31.8)
	1/4" NPT	-C642-NS4	-C642-L-NS4			3 (76.2)	1 1/4 (31.8)
712	1/4" TB	-C712-TB4	-C712-L-TB4	-C710-N	-C630-GT	2.5 (63.5)	1 3/8 (34.9)
	1/4" FR	-C712-FR4	-C712-L-FR4			3 (76.2)	1 3/8 (34.9)
	1/4" NPT	-C712-NS4	-C712-L-NS4			3 (76.2)	1 3/8 (34.9)
714	1/4" TB	-C714-TB4	-C714-L-TB4	-C710-N	-C630-GT	2.5 (63.5)	1 3/8 (34.9)
	1/4" FR	-C714-FR4	-C714-L-FR4			3 (76.2)	1 3/8 (34.9)
	1/4" NPT	-C714-NS4	-C714-L-NS4			3 (76.2)	1 3/8 (34.9)
716	1/4" TB	-C716-TB4	-C716-L-TB4	-C710-N	-C630-GT	2.5 (63.5)	1 3/8 (34.9)
	1/4" FR	-C716-FR4	-C716-L-FR4			3 (76.2)	1 3/8 (34.9)
	1/4" NPT	-C716-NS4	-C716-L-NS4			3 (76.2)	1 3/8 (34.9)
718	1/4" TB	-C718-TB4	-C718-L-TB4	-C710-N	-C630-GT	2.5 (63.5)	1 3/8 (34.9)
	1/4" FR	-C718-FR4	-C718-L-FR4			3 (76.2)	1 3/8 (34.9)
	1/4" NPT	-C718-NS4	-C718-L-NS4			3 (76.2)	1 3/8 (34.9)
720	1/4" TB	-C720-TB4	-C720-L-TB4	-C720-N	-C630-GT	2.5 (63.5)	1 3/8 (34.9)
	1/4" FR	-C720-FR4	-C720-L-FR4			3 (76.2)	1 3/8 (34.9)
	1/4" NPT	-C720-NS4	-C720-L-NS4			3 (76.2)	1 3/8 (34.9)
722	1/4" TB	-C722-TB4	-C722-L-TB4	-C720-N	-C630-GT	2.5 (63.5)	1 3/8 (34.9)
	1/4" FR	-C722-FR4	-C722-L-FR4			3 (76.2)	1 3/8 (34.9)
	1/4" NPT	-C722-NS4	-C722-L-NS4			3 (76.2)	1 3/8 (34.9)
724	1/4" TB	-C724-TB4	-C724-L-TB4	-C720-N	-C630-GT	2.5 (63.5)	1 3/8 (34.9)
	1/4" FR	-C724-FR4	-C724-L-FR4			3 (76.2)	1 3/8 (34.9)
	1/4" NPT	-C724-NS4	-C724-L-NS4			3 (76.2)	1 3/8 (34.9)
726	1/4" TB	-C726-TB4	-C726-L-TB4	-C720-N	-C630-GT	2.5 (63.5)	1 3/8 (34.9)
	1/4" FR	-C726-FR4	-C726-L-FR4			3 (76.2)	1 3/8 (34.9)
	1/4" NPT	-C726-NS4	-C726-L-NS4			3 (76.2)	1 3/8 (34.9)
728	1/4" TB	-C728-TB4	-C728-L-TB4	-C720-N	-C630-GT	2.5 (63.5)	1 3/8 (34.9)
	1/4" FR	-C728-FR4	-C728-L-FR4			3 (76.2)	1 3/8 (34.9)
	1/4" NPT	-C728-NS4	-C728-L-NS4			3 (76.2)	1 3/8 (34.9)

Note:  
 Nickel is standard material for gasket. If PCTFE is required, please add a suffix of "-k" to the ordering number.  
 Example: 6L-C638-TB4-K

## Gaskets

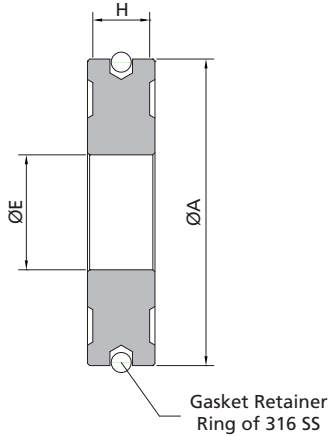

CGA Number	Gasket Ordering Number	Material	Dimensions					
			A		E		H	
			in.	mm	in.	mm	in.	mm
632~728	NI-C630-GT	Nickel 200	0.56	14.3	0.21	5.4	0.105	2.7
	K-C630-GT	PCTFE	0.56	14.3	0.21	5.4	0.125	3.2
	AL-C630-GT	Aluminum	0.56	14.3	0.21	5.4	0.105	2.7

## Outlet Adaptors

Female NPT

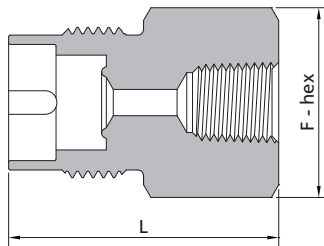

Male Face Seal (FR)

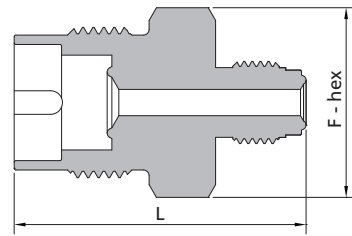

CGA Number	Basic Ordering Number	Dimensions, in. (mm)	
		L	F
632	-C632-A-FNS4	1.85 (47.0)	1 1/8 (28.6)
634	-C634-A-FNS4	1.85 (47.0)	1 1/8 (28.6)
636	-C636-A-FNS4	1.85 (47.0)	1 1/8 (28.6)
638	-C638-A-FNS4	1.85 (47.0)	1 1/8 (28.6)
640	-C640-A-FNS4	1.85 (47.0)	1 1/8 (28.6)
642	-C642-A-FNS4	1.85 (47.0)	1 1/8 (28.6)
712	-C712-A-FNS4	1.85 (47.0)	1 1/4 (31.8)
714	-C714-A-FNS4	1.85 (47.0)	1 1/4 (31.8)
716	-C716-A-FNS4	1.85 (47.0)	1 1/4 (31.8)
718	-C718-A-FNS4	1.85 (47.0)	1 1/4 (31.8)
720	-C720-A-FNS4	1.85 (47.0)	1 1/4 (31.8)
722	-C722-A-FNS4	1.85 (47.0)	1 1/4 (31.8)
724	-C724-A-FNS4	1.85 (47.0)	1 1/4 (31.8)
726	-C726-A-FNS4	1.85 (47.0)	1 1/4 (31.8)
728	-C728-A-FNS4	1.85 (47.0)	1 1/4 (31.8)

CGA Number	Basic Ordering Number	Dimensions, in. (mm)	
		L	F
632	-C632-A-FR4	2.0 (50.8)	1 1/8 (28.6)
634	-C634-A-FR4	2.0 (50.8)	1 1/8 (28.6)
636	-C636-A-FR4	2.0 (50.8)	1 1/8 (28.6)
638	-C638-A-FR4	2.0 (50.8)	1 1/8 (28.6)
640	-C640-A-FR4	2.0 (50.8)	1 1/8 (28.6)
642	-C642-A-FR4	2.0 (50.8)	1 1/8 (28.6)
712	-C712-A-FR4	2.0 (50.8)	1 1/4 (31.8)
714	-C714-A-FR4	2.0 (50.8)	1 1/4 (31.8)
716	-C716-A-FR4	2.0 (50.8)	1 1/4 (31.8)
718	-C718-A-FR4	2.0 (50.8)	1 1/4 (31.8)
720	-C720-A-FR4	2.0 (50.8)	1 1/4 (31.8)
722	-C722-A-FR4	2.0 (50.8)	1 1/4 (31.8)
724	-C724-A-FR4	2.0 (50.8)	1 1/4 (31.8)
726	-C726-A-FR4	2.0 (50.8)	1 1/4 (31.8)
728	-C728-A-FR4	2.0 (50.8)	1 1/4 (31.8)

## Blank Plugs

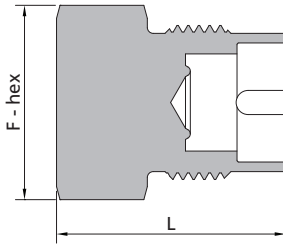

CGA Number	Basic Ordering Number	Dimensions, in. (mm)	
		L	F
632	-C632-BP	1.53 (38.9)	1 1/8 (28.6)
634	-C634-BP	1.53 (38.9)	1 1/8 (28.6)
636	-C636-BP	1.53 (38.9)	1 1/8 (28.6)
638	-C638-BP	1.53 (38.9)	1 1/8 (28.6)
640	-C640-BP	1.53 (38.9)	1 1/8 (28.6)
642	-C642-BP	1.53 (38.9)	1 1/8 (28.6)
712	-C712-BP	1.53 (38.9)	1 1/4 (31.8)
714	-C714-BP	1.53 (38.9)	1 1/4 (31.8)
716	-C716-BP	1.53 (38.9)	1 1/4 (31.8)
718	-C718-BP	1.53 (38.9)	1 1/4 (31.8)
720	-C720-BP	1.53 (38.9)	1 1/4 (31.8)
722	-C722-BP	1.53 (38.9)	1 1/4 (31.8)
724	-C724-BP	1.53 (38.9)	1 1/4 (31.8)
726	-C726-BP	1.53 (38.9)	1 1/4 (31.8)
728	-C728-BP	1.53 (38.9)	1 1/4 (31.8)

## Valve Outlet Caps (Including Chains, Rings and Gaskets)

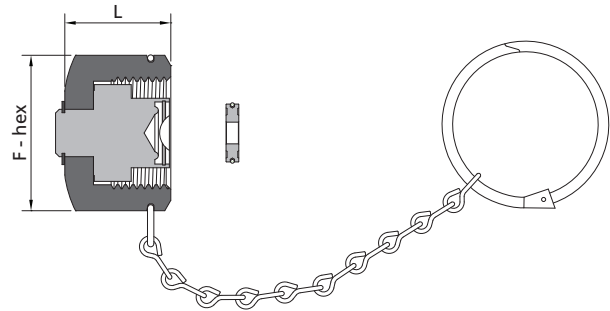

CGA Number	Basic Ordering Number	Dimensions, in. (mm)	
		L	F
632	-C632-CP	0.98 (24.9)	1 1/4 (31.8)
634	-C634-CP	0.98 (24.9)	1 1/4 (31.8)
636	-C636-CP	0.98 (24.9)	1 1/4 (31.8)
638	-C638-CP	0.98 (24.9)	1 1/4 (31.8)
640	-C640-CP	0.98 (24.9)	1 1/4 (31.8)
642	-C642-CP	0.98 (24.9)	1 1/4 (31.8)
712	-C712-CP	0.98 (24.9)	1 3/8 (34.9)
714	-C714-CP	0.98 (24.9)	1 3/8 (34.9)
716	-C716-CP	0.98 (24.9)	1 3/8 (34.9)
718	-C718-CP	0.98 (24.9)	1 3/8 (34.9)
720	-C720-CP	0.98 (24.9)	1 3/8 (34.9)
722	-C722-CP	0.98 (24.9)	1 3/8 (34.9)
724	-C724-CP	0.98 (24.9)	1 3/8 (34.9)
726	-C726-CP	0.98 (24.9)	1 3/8 (34.9)
728	-C728-CP	0.98 (24.9)	1 3/8 (34.9)

Note:  
 Nickel is standard material for gasket. If PCTFE is required, please add a suffix of "-k" to the ordering number.  
 Example: 6L-C632-CP-K

# CGA Series

- ⦿ CGA V-1-2005 compliant
- ⦿ For nipples with TB or FR connections, inner surface electropolished to an average of Ra 9 µin. (0.23 µm); Ra 32 µin. (0.8 µm) for nipples with NPT connections
- ⦿ Cleaned and packaged for Oxygen service
- ⦿ Maximum allowable leak rate:  $1 \times 10^{-9}$  mbar·l/s

## Cylinder Connections (Including Nipples, Nuts and Gaskets)

Dimensions are in. (mm).

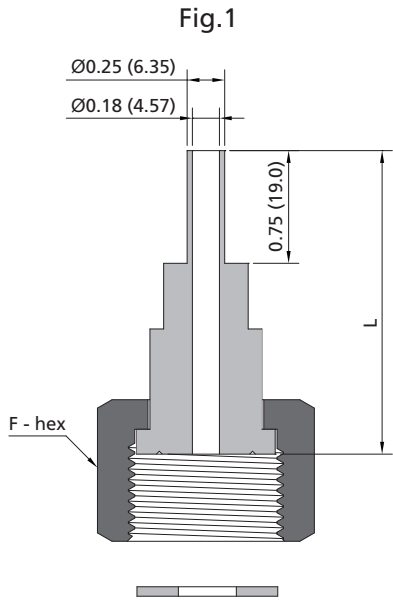

1/4" Butt Weld (TB)

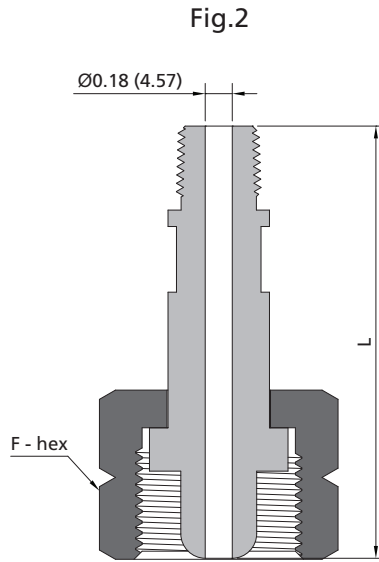

Male NPT

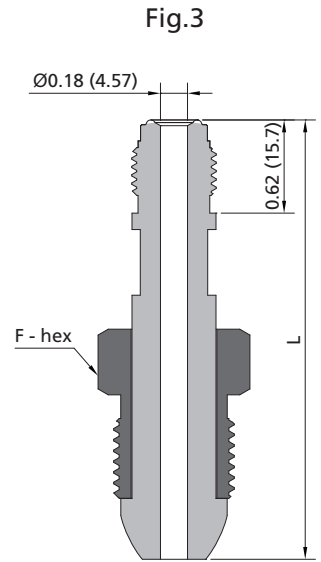

Male Face Seal (FR)

CGA Number	Ref. Fig.	End Connection	Assembly Basic Ordering Number	Nipple Basic Ordering Number	Nut Basic Ordering Number	Gasket Basic Ordering Number	Dimensions, in. (mm)	
							L	F
170	Fig. 1	1/4" TB	-C170-TB4	-C170-L-TB4	-C170-N	-C170-GT	1.25 (31.8)	11/16 (17.5)
		1/8" NPT	-C170-NS2	-C170-L-NS2				
180	Fig. 1	1/4" TB	-C180-TB4	-C180-L-TB4	-C180-N	-C180-GT	1.25 (31.8)	3/4 (19.1)
		1/8" NPT	-C180-NS2	-C180-L-NS2				
290	Fig. 2	1/4" TB	-C290-TB4	-C290-L-TB4	-C290-N	—	2.63 (66.7)	1 (25.4)
		1/4" NPT	-C290-NS4	-C290-L-NS4				
296	Fig. 3	1/4" TB	-C296-TB4	-C296-L-TB4	-C296-N	—	2.63 (66.7)	7/8 (22.3)
		1/4" NPT	-C296-NS4	-C296-L-NS4				
		1/4" FR	-C296-FR4	-C296-L-FR4				
320	Fig. 1	1/4" TB	-C320-TB4	-C320-L-TB4	-C320-N	-C320-GT	1.75 (44.5)	1 1/8 (28.6)
		1/4" NPT	-C320-NS4	-C320-L-NS4				
		1/4" FR	-C320-FR4	-C320-L-FR4				

CGA Number	Ref. Fig.	End Connection	Assembly Basic Ordering Number	Nipple Basic Ordering Number	Nut Basic Ordering Number	Gasket Basic Ordering Number	Dimensions, in. (mm)	
							L	F
326	Fig.2	1/4" TB	-C326-TB4	-C326-L-TB4	-C326-N	—	2.25 (57.2)	1 1/8 (28.6)
		1/4" NPT	-C326-NS4	-C326-L-NS4			3.0 (76.2)	
		1/4" FR	-C326-FR4	-C326-L-FR4			2.25 (57.2)	
330	Fig.1	1/4" TB	-C330-TB4	-C320-L-TB4	-C330-N	-C320-GT	1.75 (44.5)	1 1/8 (28.6)
		1/4" NPT	-C330-NS4	-C320-L-NS4			2.5 (63.5)	
		1/4" FR	-C330-FR4	-C320-L-FR4			1.75 (44.5)	
346	Fig.2	1/4" TB	-C346-TB4	-C346-L-TB4	-C346-N	—	2.31 (58.7)	1 1/8 (28.6)
		1/4" NPT	-C346-NS4	-C346-L-NS4			3.0 (76.2)	
		1/4" FR	-C346-FR4	-C346-L-FR4			2.25 (57.2)	
350	Fig.2	1/4" TB	-C350-TB4	-C350-L-TB4	-C350-N	—	2.31 (58.7)	1 1/8 (28.6)
		1/4" NPT	-C350-NS4	-C350-L-NS4			3.0 (76.2)	
		1/4" FR	-C350-FR4	-C350-L-FR4			2.25 (57.2)	
510	Fig.3	1/4" TB	-C510-TB4	-C510-L-TB4	-C510-N	—	2.63 (66.7)	1 1/8 (28.6)
		1/4" NPT	-C510-NS4	-C510-L-NS4			3.5 (88.9)	
		1/4" FR	-C510-FR4	-C510-L-FR4			2.75 (69.9)	
540 <sup>Ⓞ</sup>	Fig.2	1/4" TB	-C540-TB4	-C540-L-TB4	-C540-N	—	2.25 (57.2)	1 1/8 (28.6)
		1/4" NPT	-C540-NS4	-C540-L-NS4			3.0 (76.2)	
		1/4" FR	-C540-FR4	-C540-L-FR4			2.25 (57.2)	
580	Fig.3	1/4" TB	-C580-TB4	-C510-L-TB4	-C580-N	—	2.63 (66.7)	1 1/8 (28.6)
		1/4" NPT	-C580-NS4	-C510-L-NS4			3.5 (88.9)	
		1/4" FR	-C580-FR4	-C510-L-FR4			2.75 (69.9)	
590	Fig.3	1/4" TB	-C590-TB4	-C510-L-TB4	-C590-N	—	2.63 (66.7)	1 1/8 (28.6)
		1/4" NPT	-C590-NS4	-C510-L-NS4			3.5 (88.9)	
		1/4" FR	-C590-FR4	-C510-L-FR4			2.75 (69.9)	
660	Fig.1	1/4" TB	-C660-TB4	-C660-L-TB4	-C660-N	-C660-GT	2.19 (55.6)	1 1/4 (31.8)
		1/4" NPT	-C660-NS4	-C660-L-NS4			2.5 (63.5)	
		1/4" FR	-C660-FR4	-C660-L-FR4			1.88 (47.6)	
670	Fig.1	1/4" TB	-C670-TB4	-C660-L-TB4	-C670-N	-C660-GT	2.19 (55.6)	1 1/4 (31.8)
		1/4" NPT	-C670-NS4	-C660-L-NS4			2.5 (63.5)	
		1/4" FR	-C670-FR4	-C660-L-FR4			1.88 (47.6)	
678	Fig.1	1/4" TB	-C678-TB4	-C678-L-TB4	-C678-N	-C678-GT	2.5 (63.5)	1 1/4 (31.8)
		1/4" NPT	-C678-NS4	-C678-L-NS4			2.5 (63.5)	
		1/4" FR	-C678-FR4	-C678-L-FR4			2.0 (50.8)	
679	Fig.1	1/4" TB	-C679-TB4	-C679-L-TB4	-C679-N	-C679-GT	2.5 (63.5)	1 1/4 (31.8)
		1/4" NPT	-C679-NS4	-C679-L-NS4			3.0 (76.2)	
		1/4" FR	-C679-FR4	-C679-L-FR4			2.0 (50.8)	

Ⓞ Cleaned and packaged for Oxygen Service.

Note:  
 PTFE is standard material for gasket. If PCTFE is required, please add a suffix of "-k" to the ordering number.  
 Example: 6L-C170-FR4-K

## Gaskets

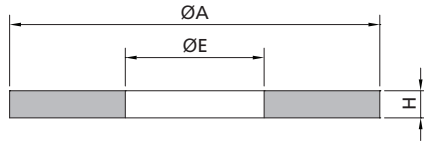

CGA Number	Gasket Basic Ordering Number	Dimensions					
		A		E		H	
		in.	mm	in.	mm	in.	mm
170	-C170-GT	0.43	11.0	0.19	4.8	0.10	2.5
180	-C180-GT	0.44	11.2	0.32	8.1	0.09	2.3
320, 330	-C320-GT	0.72	18.3	0.26	6.6	0.09	2.3
660, 670	-C660-GT	0.94	23.9	0.38	9.7	0.06	1.6
678	-C678-GT	0.61	15.5	0.30	7.6	0.06	1.6
679	-C679-GT	0.53	13.5	0.31	7.9	0.06	1.6

# Outlet Adaptors, Blank Caps and Plugs

## Blank Caps CGA 580

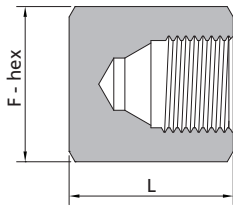

## Blank Plugs CGA 350

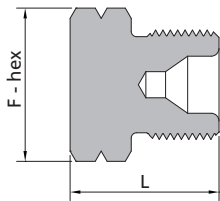

## Male Face Seal (FR) CGA 350

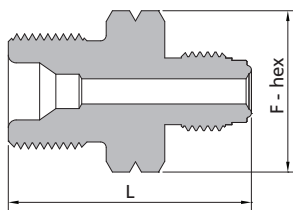

## Female NPT CGA 350

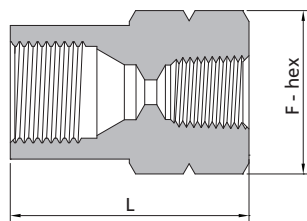

CGA Number	End Connection	Assembly Basic Ordering Number	Dimensions, in. (mm)	
			L	F
180	1/4" Female NPT	-C180-A-FNS4	1.38 (35.0)	3/4 (19.1)
296	Blank Cap	-C296-BC	1.37 (34.8)	1 1/8 (28.6)
	1/4" Female NPT	-C296-A-FNS4	2.0 (50.8)	
320	1/4" FR	-C296-A-FR4	2.0 (50.8)	1 (25.4)
	Blank Plug	-C320-BP	1.12 (28.4)	
	1/4" Female NPT	-C320-A-FNS4	1.12 (28.4)	
326	1/4" FR	-C320-A-FR4	1.74 (44.2)	1 (25.4)
	Blank Plug	-C326-BP	1.12 (28.4)	
330	1/4" Female NPT	-C326-A-FNS4	1.31 (33.3)	1 (25.4)
	1/4" FR	-C326-A-FR4	1.74 (44.2)	
	Blank Plug	-C330-BP	1.12 (28.4)	
346	1/4" Female NPT	-C330-A-FNS4	1.31 (33.3)	1 (25.4)
	1/4" FR	-C330-A-FR4	1.74 (44.2)	
	Blank Plug	-C346-BP	1.12 (28.4)	
350	1/4" Female NPT	-C346-A-FNS4	1.31 (33.3)	1 (25.4)
	1/4" FR	-C346-A-FR4	1.88 (47.8)	
	Blank Plug	-C350-BP	1.12 (28.4)	
510	1/4" Female NPT	-C350-A-FNS4	1.31 (33.3)	1 (25.4)
	1/4" FR	-C350-A-FR4	1.88 (47.8)	
	Blank Plug	-C510-BP	1.12 (28.4)	
540 <sup>Ⓞ</sup>	1/4" Female NPT	-C510-A-FNS4	2.0 (50.8)	1 1/4 (31.8)
	1/4" FR	-C510-A-FR4	2.0 (50.8)	
	Blank Plug	-C540-BP	1.12 (28.4)	
580	1/4" Female NPT	-C540-A-FNS4	1.25 (31.8)	1 (25.4)
	1/4" FR	-C540-A-FR4	1.87 (47.5)	
	Blank Plug	-C580-BP	1.12 (28.4)	
580	1/4" Female NPT	-C580-A-FNS4	2.0 (50.8)	1 1/4 (31.8)
	1/4" FR	-C580-A-FR4	2.0 (50.8)	
	Blank Cap	-C580-BC	1.37 (34.8)	

Ⓞ Cleaned and packaged for Oxygen Service.



**Female NPT**

CGA 350

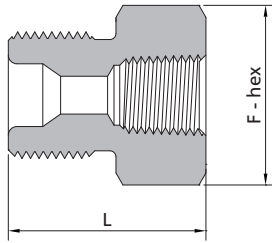

CGA Number	End Connection	Assembly Basic Ordering Number	Dimensions, in. (mm)	
			L	F
590	Blank Cap	-C590-BC	1.37 (34.8)	1 1/4 (31.8)
	1/4" Female NPT	-C590-A-FNS4	2.0 (50.8)	
	1/4" FR	-C590-A-FR4	2.0 (50.8)	
660	Blank Plug	-C660-BP	0.88 (22.4)	1 1/8 (28.6)
	1/4" Female NPT	-C660-A-FNS4	1.25 (31.8)	
	1/4" FR	-C660-A-FR4	1.5 (38.1)	
670	Blank Plug	-C670-BP	0.88 (22.4)	1 1/8 (28.6)
	1/4" Female NPT	-C670-A-FNS4	1.25 (31.8)	
	1/4" FR	-C670-A-FR4	1.5 (38.1)	
678	Blank Plug	-C678-BP	1.0 (25.4)	1 1/8 (28.6)
	1/4" Female NPT	-C678-A-FNS4	1.38 (35.1)	
	1/4" FR	-C678-A-FR4	1.5 (38.1)	
679	Blank Plug	-C679-BP	0.88 (22.4)	1 1/8 (28.6)
	1/4" Female NPT	-C679-A-FNS4	1.25 (31.8)	
	1/4" FR	-C679-A-FR4	1.75 (44.5)	

Gas Control Equipment

Related Products

Technical References

**Cylinder Valve Outlet Plugs**

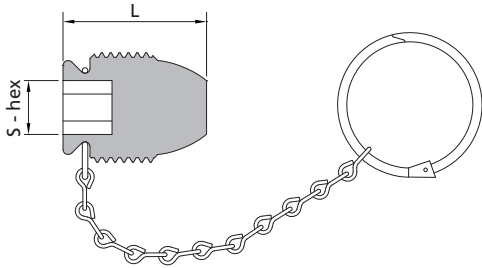

CGA Number	Basic Ordering Number	Dimensions, in. (mm)	
		L	S
510	-C510-PG	1.0 (25.4)	3/8 (9.5)
580	-C580-PG	1.0 (25.4)	
590	-C590-PG	1.0 (25.4)	

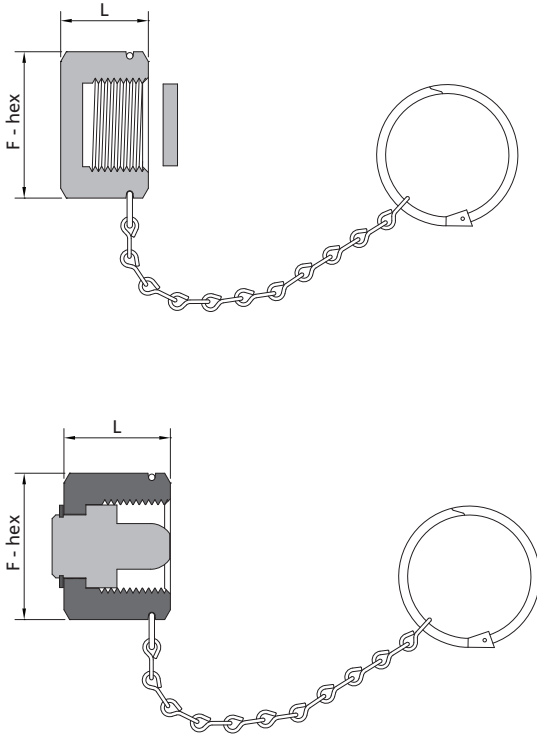

CGA Number	Basic Ordering Number	Dimensions, in. (mm)	
		L	F
320	-C320-CP	0.54 (13.7)	1 (25.4)
326	-C320-CP	0.54 (13.7)	
330	-C330-CP	0.54 (13.7)	
346	-C320-CP	0.54 (13.7)	
660	-C660-CP	0.54 (13.7)	1 1/4 (31.8)
670	-C670-CP	0.54 (13.7)	
678	-C670-CP	0.54 (13.7)	
679	-C670-CP	0.54 (13.7)	

Notes:

1. PTFE is standard material for gasket. If PCTFE is required, please add a suffix of "-k" to the ordering number.  
Example: S4-C330-CP-K
2. The caps listed above are only intended to keep valve outlets clean and protect its threads. They shouldn't be used to contain pressure if the valve leaks or is opened by mistake.

CGA Number	Basic Ordering Number	Dimensions, in. (mm)	
		L	F
350	-C350-CP	0.82 (20.8)	1 1/8 (28.6)

## Complete Pigtail Connections (Including Nipples, Nuts, Gaskets and Blank Plugs or Caps)

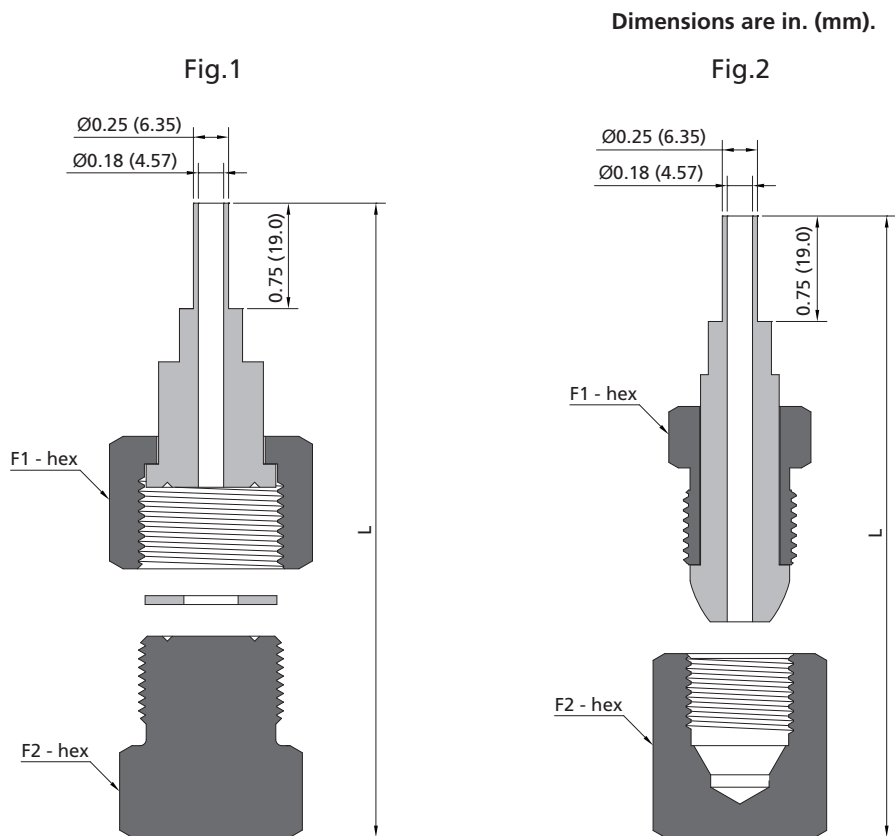

CGA Number	Ref. Fig.	Assembly Basic Ordering Number	Gasket Basic Ordering Number	Dimensions, in. (mm)		
				L	F1	F2
296	Fig.2	-C296-TB4-A	—	3.03 (77.0)	7/8 (22.3)	1 1/8 (28.6)
320	Fig.1	-C320-TB4-A	-C320-GT	2.96 (75.2)	1 1/8 (28.6)	1 (25.4)
326	Fig.1	-C326-TB4-A	—	3.01 (76.5)		
330	Fig.1	-C330-TB4-A	-C320-GT	2.96 (75.2)		
346	Fig.1	-C346-TB4-A	—	2.97 (75.4)		
350	Fig.1	-C350-TB4-A	—	2.96 (75.2)		
510	Fig.2	-C510-TB4-A	—	3.03 (77.0)		1 1/4 (31.8)
540 <sup>①</sup>	Fig.1	-C540-TB4-A	—	2.96 (75.2)		1 (25.4)
580	Fig.2	-C580-TB4-A	—	3.03 (77.0)		1 1/4 (31.8)
590	Fig.2	-C590-TB4-A	—	3.03 (77.0)		
660	Fig.1	-C660-TB4-A	-C660-GT	2.96 (75.2)		1 1/4 (31.8)
670	Fig.1	-C670-TB4-A	-C660-GT	2.96 (75.2)		
678	Fig.1	-C678-TB4-A	-C678-GT	3.08 (78.2)		
679	Fig.1	-C679-TB4-A	-C679-GT	2.96 (75.2)		

① Cleaned and packaged for Oxygen Service.

Note:

PTFE is standard material for gasket. If PCTFE is required, please add a suffix of "-k" to the ordering number.

Example: 6L-C330-TB4-A-K

## Assembly Torque For CGA Cylinder Connections

CGA NO.	Recommended Torque		CGA NO.	Recommended Torque	
	ft-lb	N·m		ft-lb	N·m
170 <sup>①</sup>	10~15	14~20	510	35~50	47~68
180 <sup>①</sup>	10~15	14~20	540	40~60	54~81
290	30~45	41~61	580	40~60	54~81
296	35~50	47~68	590	40~60	54~81
320 <sup>①</sup>	20~30	27~41	660 <sup>①</sup>	30~45	41~61
326	25~35	34~47	670 <sup>①</sup>	30~45	41~61
330 <sup>①</sup>	20~30	27~41	678 <sup>①</sup>	25~35	34~47
346	35~50	47~68	679 <sup>①</sup>	25~35	34~47
350	35~50	47~68			
CGA DISS NO.	Recommended Torque		Gasket Material		
	ft-lb	N·m			
632-728	35~40	47~53.8	Nickel		
	12~15	16~20.1	PCTFE		

① Gasket for seal: PTFE or PCTFE.

# DIN Series

- ⦿ DIN 477-1 compliant
- ⦿ For nipples with TB or FR connections, inner surface electropolished to an average of Ra 9 µin. (0.23 µm); Ra 32 µin. (0.8 µm) for nipples with NPT connections
- ⦿ Cleaned and packaged for Oxygen service
- ⦿ Maximum allowable leak rate: 1 x 10<sup>-9</sup> mbar·l/s

## Complete Pigtail Connections (Including Nipples, Nuts, Gaskets and Blank Plugs)

Dimensions are in. (mm).

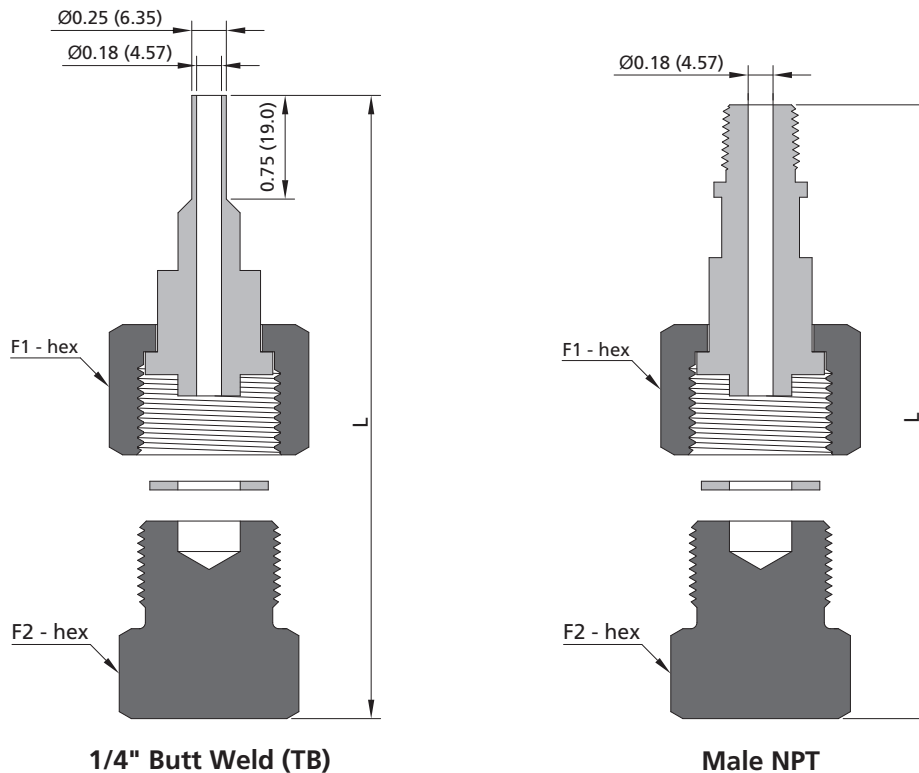

DIN Number	Assembly Basic Ordering Number	Gasket Basic Ordering Number	Dimensions, in.(mm)		
			L	F1	F2
1	-DIN1-TB4-A	-DIN1-GT	2.96 (75.2)	1 1/4 (31.8)	1 1/4 (31.8)
	-DIN1-NS4-A		4.25 (108)		
5	-DIN5-TB4-A	-DIN5-GT	3.09 (78.5)		
	-DIN5-NS4-A		4.41 (112)		
6	-DIN6-TB4-A	-DIN1-GT	2.96 (75.2)		
	-DIN6-NS4-A		4.25 (108)		
8	-DIN8-TB4-A	-DIN5-GT	3.09 (78.5)		
	-DIN8-NS4-A		4.41 (112)		
11	-DIN11-TB4-A	-DIN11-GT	2.88 (73.2)	7/8 (22.3)	11/16 (17.5)
	-DIN11-NS4-A		4.14 (105.2)		
14	-DIN14-TB4-A		2.88 (73.2)	1 1/16 (27.0)	7/8 (22.3)
	-DIN14-NS4-A		4.15 (105.5)		

**Notes:**

1. Above components can be ordered separately.
2. PTFE is standard material for gasket. If PCTFE is required, please add a suffix of "-k" to the ordering number.  
Example: 6L-D1N1-TB4-A-K

# Gas Connection Assignment Table<sup>®</sup>

GAS	Formula	UHP CGA	CGA	DIN	JIS
Ammonia	NH <sub>3</sub>	720	705	DIN6	22-R
Argon	Ar	718	580	DIN6	22-R or 23-R
Arsenic Pentafluoride	AsF <sub>5</sub>	642	—	—	—
Arsine	AsH <sub>3</sub>	632	350	—	22-L
Boron Trichloride	BCl <sub>3</sub>	634	660	DIN8	—
Boron Trifluoride	BF <sub>3</sub>	642	330	DIN8	22-L
Carbon Dioxide	CO <sub>2</sub>	716	320	DIN6	—
Carbon Monoxide	CO	724	350	DIN5	22-L
Chlorine	Cl <sub>2</sub>	728	—	DIN8	26-R
Diborane	B <sub>2</sub> H <sub>6</sub>	632	350	—	22-L
Dichlorosilane	SiH <sub>2</sub> Cl <sub>2</sub>	636	678 <sup>①</sup>	DIN5	—
Diethylzinc	Zn(C <sub>2</sub> H <sub>5</sub> ) <sub>2</sub>	726	510 <sup>②</sup>	—	—
Diethyltelluride	(C <sub>2</sub> H <sub>5</sub> ) <sub>2</sub> Te	726	—	—	—
Dimethylzinc	(CH <sub>3</sub> ) <sub>2</sub> Zn	726	—	—	—
Disilane	Si <sub>2</sub> H <sub>6</sub>	632	—	—	—
Germane	GeH <sub>4</sub>	632	350 or 660	—	—
Halocarbon 11	CCl <sub>3</sub> F	716	660	—	—
Halocarbon 115	ClCF <sub>2</sub> CF <sub>3</sub>	716	660	DIN6	—
Halocarbon 12	CCl <sub>2</sub> F <sub>2</sub>	716	660	DIN6	—
Halocarbon 13	ClCF <sub>3</sub>	716	660	DIN6	—
Halocarbon 14	CF <sub>4</sub>	716	320 or 580	DIN6	—
Halocarbon 23	CHF <sub>3</sub>	716	660	DIN6	—
Halocarbon 116	F <sub>3</sub> CCF <sub>3</sub>	716	660	—	—
Helium	He	718	580	DIN6	22-R or 23-R
Hydrogen	H <sub>2</sub>	724	350	DIN1	22-L
Hydrogen Bromide	HBr	634	330	DIN8	26-R
Hydrogen Chloride	HCl	634	330	DIN8	26-R
Hydrogen Fluoride	HF	638	660 or 670	—	26-R
Hydrogen Sulfide	H <sub>2</sub> S	722	330	DIN5	—
Krypton	Kr	718	580	DIN6	22-R or 23-R
Neon	Ne	718	580	DIN6	22-R or 23-R
Nitrogen	N <sub>2</sub>	718	580	DIN10	22-R or 23-R
Nitrogen Trifluoride	NF <sub>3</sub>	640	330 or 670	DIN8	—
Nitrous Oxide	N <sub>2</sub> O	712	326	DIN8	—
Oxygen	O <sub>2</sub>	714	540	DIN9	22-R or 23-R
Perfluoropropane	CF <sub>2</sub> (CF <sub>3</sub> )	716	660	—	—
Phosphine	PH <sub>3</sub>	632	350 or 660	DIN1	—
Phosphorus Pentafluoride	PF <sub>5</sub>	642	330 or 660	—	—
Silane	SiH <sub>4</sub>	632	350	—	—
Silicon Tetrachloride	SiCl <sub>4</sub>	636	—	—	—
Silicon Tetrafluoride	SiF <sub>4</sub>	642	330	—	22-L
Sulphur Hexafluoride	SF <sub>6</sub>	716	590	DIN6	26-R
Trichlorosilane	SiHCl <sub>3</sub>	636	—	—	—
Triethylaluminum	(C <sub>2</sub> H <sub>5</sub> ) <sub>3</sub> Al	726	510 <sup>②</sup>	—	—
Tungsten Hexafluoride	WF <sub>6</sub>	638	670	DIN8	—
Xenon	Xe	718	580	DIN6	22-R

① Refer to CGA organization specification for pressure limits.

② Information in this table is for reference only.

# B

## Related Products

Purge Assemblies . . . . .	B-02
Diaphragm Valves . . . . .	B-04
Ball Valves . . . . .	B-05
Needle Valves . . . . .	B-06
Check Valves . . . . .	B-07
Relief Valves . . . . .	B-08
Filters . . . . .	B-09
Fittings . . . . .	B-10
Metal Flexible Hoses . . . . .	B-13
Cylinder Connections . . . . .	B-14

# Purge Assemblies

## FPV-1 Series

### Technical Data

- ⊙ Maximum working pressure: 4500 psig
- ⊙ Material of the main components:  
Seat: PCTFE (diaphragm valve)  
Diaphragm: Elgiloy (diaphragm valve)
- ⊙ Temperature: -10°F~+150°F (-23°C~+65°C)
- ⊙ Leak rates:  
Internal:  $\leq 1 \times 10^{-9}$  mbar·l/s helium  
External:  $\leq 1 \times 10^{-9}$  mbar·l/s helium
- ⊙ Minimum orifice:  $\Phi 0.13$ " (3.2 mm)

### Product Types

- ⊙ Straight Purge Assemblies  
Consisting of a diaphragm valve and a check valve (see Fig. 1-1).  
Connecting the auxiliary inlet port (see Fig. 1-2) of the regulator or in between the regulator and the cylinder (see Fig. 1-3) to allow the corrosive or toxic gas to be vented through to a safe location.

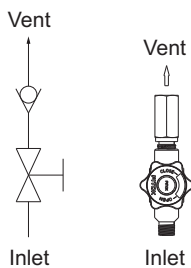

Fig. 1-1

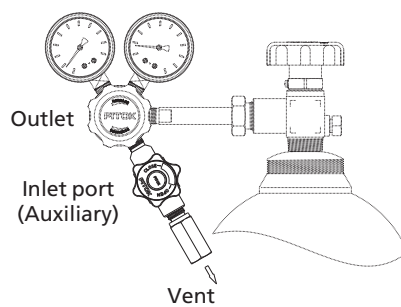

Fig. 1-2

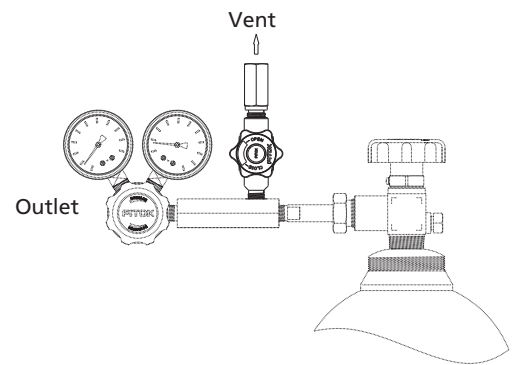

Fig. 1-3

- ⊙ Tee Purge Assemblies

Consisting of a diaphragm valve, check valve, tee, and cylinder connections (see Fig. 2-1).

Connecting the cylinder with the regulator. Before installing a new cylinder, open the diaphragm valve, and the remaining gas is vented safely; or after a new cylinder is installed, close the regulator and open the diaphragm valve, enabling the process gas inside the cylinder to purge the atmospheric contamination between the cylinder and the regulator (see Fig. 2-2).



Fig. 2-1

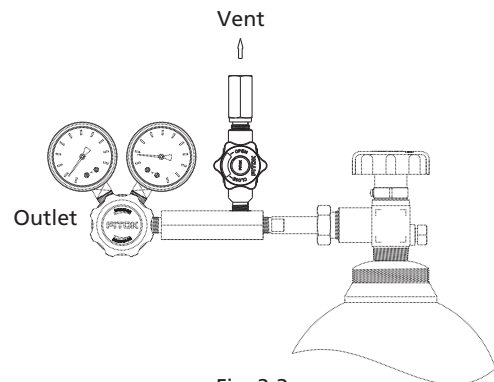

Fig. 2-2

◎ Cross Purge Assemblies

Consisting of a tee purge assembly and two additional diaphragm valves (see Fig. 3-1).

Except for process gas, purging is also made possible with inert gas from outside (see Fig. 3-2). The steps are as follows: Before installing a new cylinder, close the diaphragm valve beside the regulator, and open the shutoff diaphragm valve on the vent line to release the residual pressure.

After installing a new cylinder, open the diaphragm valve on the bottom, allowing the inert gas from outside to purge the atmospheric contaminations between the cylinder and the diaphragm valve.

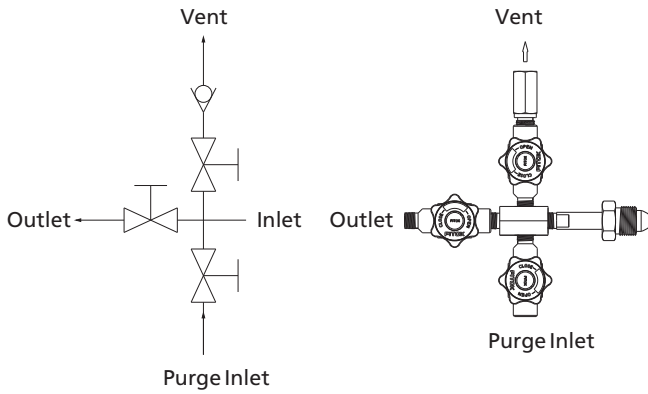

Fig. 3-1

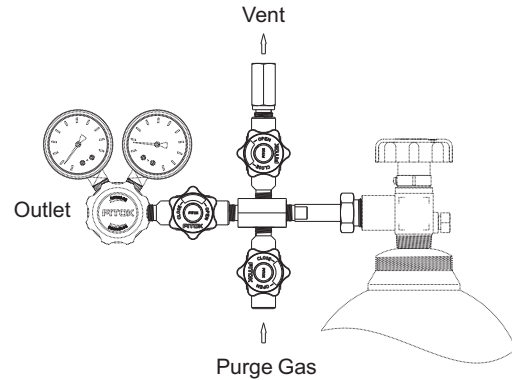

Fig. 3-2

### Part Number Description

FPV – 1C      6L      –      DIN1      –      00      –      00      –      00

Product Type		Body Material		Inlet Port		Vent Port		Outlet Port		Purge Inlet	
S	Straight Purge Assemblies	6L	316L SS	00	1/4" Female NPT	00	1/4" Female NPT	Same as Same as Vent Port		Same as Same as Vent Port	
T	Tee Purge Assemblies	SS	316 SS	01	1/4" Male NPT	01	1/4" Male NPT				
C	Cross Purge Assemblies			C_ _ _	CGA Number (USA)	10	1/4" Tube Fitting				
				DIN_	DIN Number (Germany)	20	6 mm Tube Fitting				
					Refer to page B-28 for cylinder connections based on specific gas type. Cylinder connections compliant to other standards are available upon request. Please contact FITOK Group for details.	21	8 mm Tube Fitting				
							Other connections are available upon request				





# Ball Valves

## BO Series

### Features

- One-piece body and one-piece ball stem
- No dead zone, such as in the area between the ball and valve chamber
- In-line inspection and repair with top entry design
- Thermal cycle performance improved and wear compensated by live-loaded design
- Multiple connections available
- Pneumatic and electric actuators available



### Technical Data

- Maximum working pressure: 3000 psig (207 bar)
- Temperature: -65°F to 300°F (-54°C to 148°C)
- Seat material: PTFE

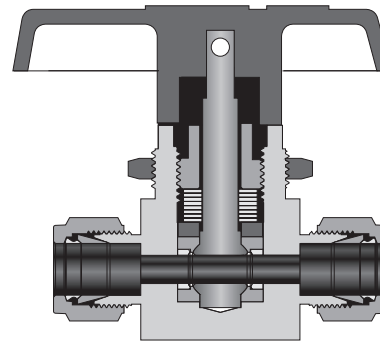

### Part Number Description

<b>BO</b>		<b>6L</b>		<b>-</b>		<b>NS</b>		<b>4</b>		<b>-</b>		<b>FNS</b>		<b>4</b>		<b>-</b>		<b>H03</b>		<b>-</b>		<b>U</b>		<b>A</b>		<b>-</b>		<b>F2</b>	
<b>Body Material</b>		<b>Connection 1 Type</b>		<b>Connection 2 Type</b>		<b>Connection 2 Size</b>		<b>Orifice Size</b>		<b>Flow Pattern</b>		<b>Technology Grade</b>		<b>Handle</b>		<b>Seat Material</b>													
<b>6L</b>	316L SS	<b>FNS</b>	Female NPT	Same as Connection 1		Specify in the same way as inlet type		<b>02</b>	0.09" (2.4 mm)	Straight		General Purpose		Black Nylon		PTFE													
<b>SS</b>	316 SS	<b>NS</b>	Male NPT	Specify in the same way as inlet type				<b>03</b>	0.13" (3.2 mm)	A Angle		F2 Special Cleaning and Packaging		C Red Nylon		H UHMWPE													
<b>B</b>	Brass	<b>FR</b>	Male FR Fitting	Specify in the same way as inlet size				<b>05</b>	0.19" (4.8 mm)					J Blue Nylon		A PFA													
		<b>FL</b>	Fractional Tube Fitting					<b>07</b>	0.28" (7.1 mm)					U Black Aluminium															
		<b>ML</b>	Metric Tube Fitting					<b>10</b>	0.41" (10.3 mm)																				
		<b>Connection 1 Size</b>																											
		<b>4</b>	1/4"																										
		<b>6</b>	6 mm or 3/8"																										
		<b>8</b>	8 mm or 1/2"																										

# Needle Valves

## ND Series

### Features

- ⦿ One-piece forged body
- ⦿ Straight and angle patterns
- ⦿ Compact design
- ⦿ Non-rotating stem
- ⦿ Specially designed handle to stop contamination from entering into the valve



### Technical Data

- ⦿ Maximum working pressure: 3000 psig (207 bar)
- ⦿ Temperature:
  - PCTFE stem tip: -20°F to 200°F (-28°C to 93°C)
  - PEEK stem tip: -20°F to 450°F (-28°C to 232°C)

### Part Number Description

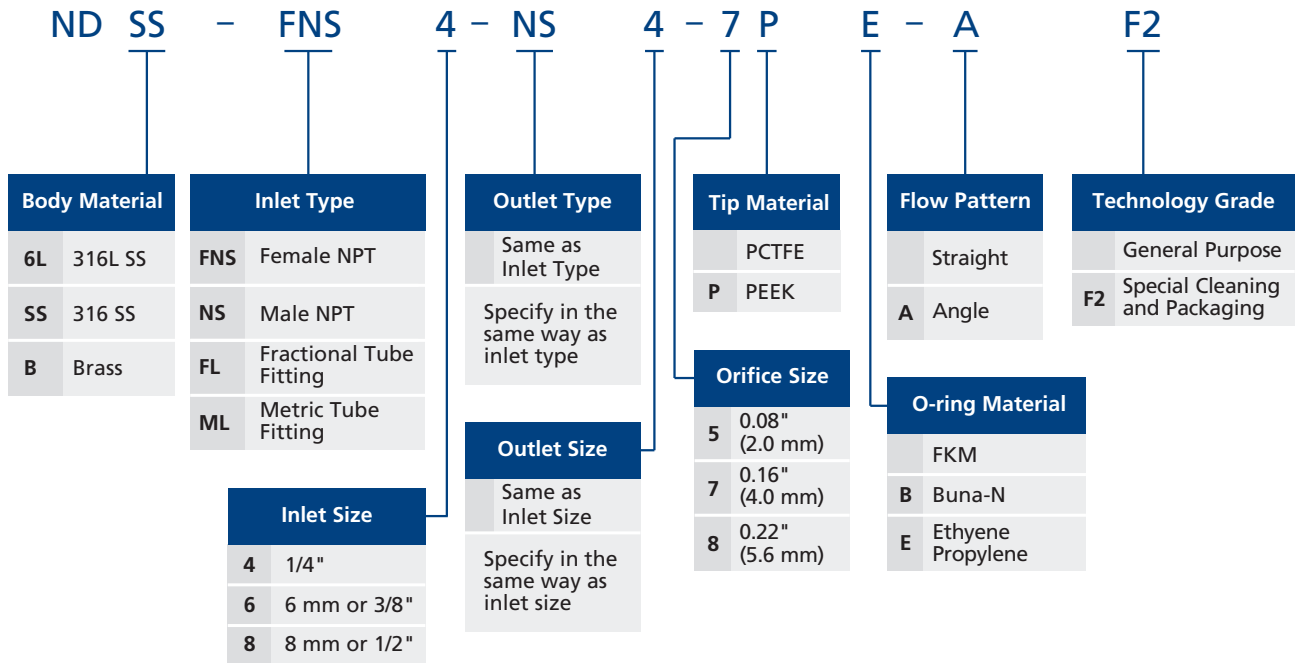

# Check Valves

## CV, CO and COA Series

### Features

- Resilient O-ring seat design for leak-free sealing
- Maximum working pressure: 3000 psig (207 bar)
- Temperature: -10°F to 375°F (-23°C to 190°C)
- PTFE-coated spring available

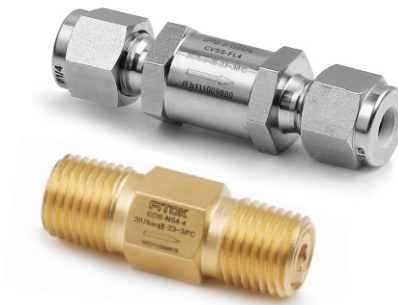

### CV Series

- Fixed cracking pressure: 1/3 to 25 psig (0.02 to 1.7 bar)

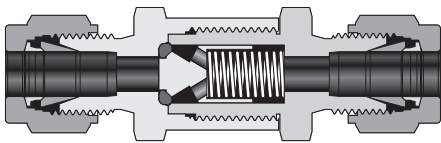

### CO Series

- Compact design with one-piece body
- Fixed cracking pressure: 1/3 to 25 psig (0.02 to 1.7 bar)

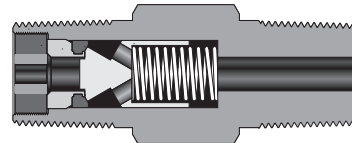

### COA Series

- Adjustable cracking pressure: 3 to 600 psig (0.02 to 41.4 bar)
- A variety of springs available

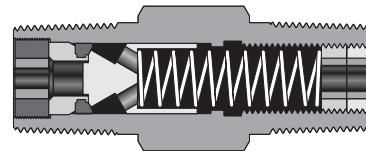

### Part Number Description

Series	Inlet Type	Inlet Size	Outlet Size	Cracking Pressure	Technology Grade	
CV	FNS Female NPT	4 1/4"	Same as Inlet Size	3 psig	General Purpose	
CO	NS Male NPT	6 6 mm or 3/8"	Specify in the same way as inlet size	1 1/3 psig	F2 Special Cleaning and Packaging	
COA	FL Fractional Tube Fitting (only for CV Series)	8 8 mm or 1/2"		2 1 psig		
Body Material	ML Metric Tube Fitting (only for CV Series)	Outlet Type	Seal Material	3 10 psig	CV and CO	
	FR Male FR Fitting (only for CV Series)	Same as Inlet Type		4 25 psig		
	6L 316L SS	Specify in the same way as inlet type		5 3 to 50 psig		COA
	SS 316 SS			6 50 to 150 psig		
	B Brass			7 150 to 350 psig		
			7 350 to 600 psig			
			B Buna-N			
			N Neoprene			
			E Ethylene Propylene			
			Z Kalrez			

# Relief Valves

## RUV and RV Series

### Introduction

Relief valve opens when system pressure exceeds the set pressure, allowing the medium to flow out to relieve the system pressure and closes when the system pressure decreases to the resealing pressure.

### RUV Series

- ⦿ Compact design with one-piece body
- ⦿ Standard seat: FKM
- ⦿ Temperature: -10°F to 300°F (-23°C to 148°C)
- ⦿ Cracking pressure: 25 to 500 psig (1.7 to 34.5 bar)
- ⦿ Set pressure by nut adjustment and spring replacement

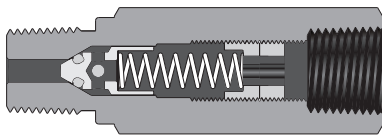

### RV Series

- ⦿ Working temperature: -10°F to 300°F (-23°C to 148°C)
- ⦿ Cracking pressure: 50 to 6000 psig
- ⦿ Adjustable bonnet cap for pressure setting
- ⦿ Lead-seal line protected

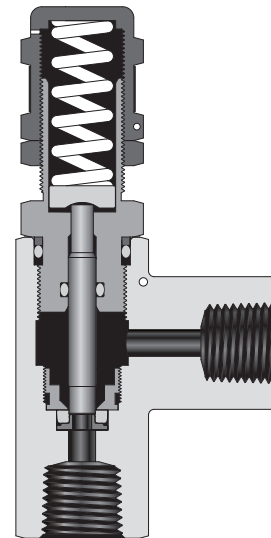

### Temperature Range of Sealing Material

O-ring Material	Temperature Range °F (°C)
Fluorocarbon Rubber	25 to 250 (-4 to 121)
Buna-N Rubber	0 to 250 (-17 to 121)
Neoprene Rubber	-10 to 300 (-23 to 148)
Ethylene Propylene Rubber	30 to 250 (-1 to 121)

### Part Number Description

Series	Inlet Type	Outlet Type	Orifice Size	Set Pressure	Technology Grade
RUV	FNS Female NPT	Same as Inlet Type	0.14" (3.6 mm) (only for RUV Series)	0 10 to 25 psig	General Purpose
RV	NS Male NPT	Specify in the same way as inlet type	0.14" (3.6 mm) (only for RV Series)	1 25 to 100 psig	F2 Special Cleaning and Packaging
	FL Fractional Tube Fitting (only for RV Series)		6	2 100 to 250 psig	
	ML Metric Tube Fitting (only for RV Series)			3 250 to 500 psig	
		Outlet Size		F 50 to 300 psig	
		Same as Inlet Size		O 300 to 700 psig	
		Specify in the same way as inlet size		Y 700 to 1500 psig	
				P 1500 to 2500 psig	
				W 2500 to 3500 psig	
				J 3500 to 4500 psig	
				C 4500 to 6000 psig	

Body Material	Inlet Size	Seal Material
6L 316L SS	4 1/4"	FKM
SS 316 SS	6 6 mm or 3/8"	B Buna-N
	8 8 mm or 1/2"	N Neoprene
		E Ethylene Propylene
		Z Kalrez

# Filters

## FT Series

### Tee-type Filters

- Maximum working pressure: 6000 psig (414 bar)
- Temperature: -20 °F to 900 °F (-28°C to 482 °C)
- Filter element replaceable without removing body from system

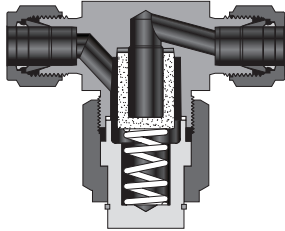

## FB Series

### Bypass Filters

- Maximum working pressure: 6000 psig (414 bar)
- Temperature: -20 °F to 900 °F (-28°C to 482 °C)
- Bypass port at filter bottom for easy sampling and purging

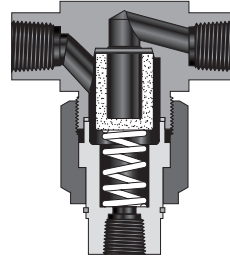

## FI Series

### In-line Filters

- Maximum working pressure: 3000 psig (207 bar)
- Temperature: -20 °F to 900 °F (-28°C to 482 °C)
- Compact and space-saving design

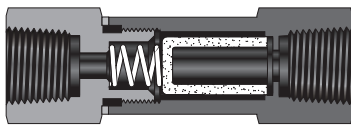

## FW Series

### All-welded In-line Filters

- Maximum working pressure: 6000 psig (414 bar)
- Temperature: -20 °F to 900 °F (-28°C to 482 °C)
- Large filtration area and high flow coefficient
- All-welded construction to eliminate leakage

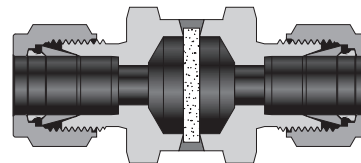

## Part Number Description

Series	Inlet Type	Outlet Type	Element Type	Pore Size (µm)	Bypass Port (for FB Series only)
FT	FNS Female NPT	Same as Inlet Type	Sintered	05	1/8" Female NPT
FB	NS Male NPT	Specify in the same way as inlet type	S	2	FL 4 1/4" Fractional Tube Fitting
FI	FL Fractional Tube Fitting		Gasket Material	7	TS 4 1/4" Tube Socket Weld
FW	ML Metric Tube Fitting	Outlet Size		15	FL 6 3/8" Fractional Tube Fitting
	FR Male FR Fitting	Same as Inlet Size	40		
		Specify in the same way as inlet size	P	60	Technology Grade
			PTFE-plated 316 SS for FT, FB, FI Series	80	
			A	100	General Purpose
			W	150	F2 Special Cleaning and Packaging
				250	
				400	

# Fittings



## Features

- ⦿ Sizes ranging from 1/4" to 1/2" and 6 mm to 12 mm
- ⦿ Diverse material and configurations available
- ⦿ Precision machined components to ensure perfect deformation of the ferrules and tubing
- ⦿ Hardened threads with smooth surface finish to avoid galling and to help extend the fitting cycle life
- ⦿ Silver-plated female nut threads to reduce friction against the body threads
- ⦿ Radius junction design with elbows to provide smooth flow path
- ⦿ Every fitting marked with size, material and heat number

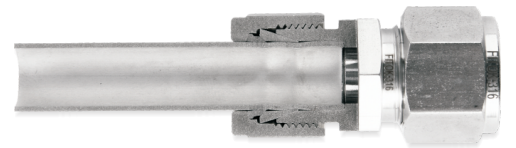

# Ordering Information and Dimensions

Dimensions are shown with FITOK nuts finger-tight.

## Male Connectors

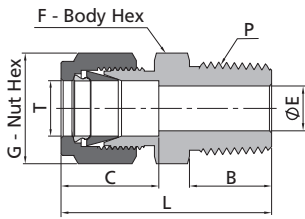

Fractional Tube			NPT Thread					
T-Tube O.D. (in.)	P-NPT Size	Basic Ordering Number	Dimension, in. (mm)					
			L	B	C	E	G	F
1/4	1/4	-CM-FL4-NS4	1.49(37.8)	0.56(14.2)	0.60(15.2)	0.19(4.8)	0.56(14.3)	0.56(14.3)
3/8	3/8	-CM-FL6-NS6	1.57(39.9)	0.56(14.2)	0.66(16.8)	0.28(7.1)	0.69(17.5)	0.69(17.5)
1/2	1/2	-CM-FL8-NS8	1.93(49.0)	0.75(19.1)	0.90(22.9)	0.41(10.4)	0.87(22.2)	0.87(22.2)

Metric Tube			NPT Thread					
T-Tube O.D. (mm)	P-NPT Size	Basic Ordering Number	Dimension, mm (in.)					
			L	B	C	E	G	F
6	1/4	-CM-ML6-NS4	37.9(1.49)	14.2(0.56)	15.3(0.60)	4.8(0.19)	14.0(0.55)	14.0(0.55)
8	3/8	-CM-ML8-NS6	39.3(1.55)	14.2(0.56)	16.2(0.64)	6.4(0.25)	16.0(0.63)	18.0(0.71)
10	3/8	-CM-ML10-NS6	40.9(1.61)	14.2(0.56)	17.2(0.68)	7.9(0.31)	19.0(0.75)	18.0(0.71)
12	1/2	-CM-ML12-NS8	49.0(1.93)	19.1(0.75)	22.8(0.90)	9.5(0.37)	22.0(0.87)	22.0(0.87)

## Unions

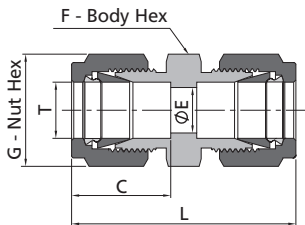

Fractional Tube		Dimension, in. (mm)				
T-Tube O.D. (in.)	Basic Ordering Number	L	C	G	F	E
		1/4	-U-FL4	1.61(40.9)	0.60(15.2)	0.56(14.3)
3/8	-U-FL6	1.77(45.0)	0.66(16.8)	0.69(17.5)	0.63(15.9)	0.28(7.1)
1/2	-U-FL8	2.02(51.3)	0.90(22.9)	0.87(22.2)	0.81(20.6)	0.41(10.4)

Metric Tube		Dimension, mm (in.)				
T-Tube O.D. (mm)	Basic Ordering Number	L	C	G	F	E
		6	-U-ML6	41.0(1.61)	15.3(0.60)	14.0(0.55)
8	-U-ML8	43.2(1.70)	16.2(0.64)	16.0(0.63)	15.0(0.59)	6.4(0.25)
10	-U-ML10	46.2(1.82)	17.2(0.68)	19.0(0.75)	18.0(0.71)	7.9(0.31)
12	-U-ML12	51.2(2.02)	22.8(0.90)	22.0(0.87)	22.0(0.87)	9.5(0.37)

## Conversion Unions

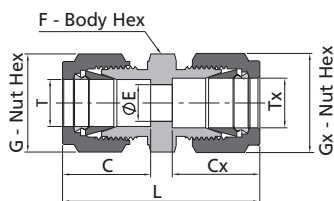

Metric Tube			Fractional Tube						
T-Tube O.D. (mm)	Tx-Tube O.D. (in.)	Basic Ordering Number	Dimension, mm (in.)						
			L	C	G	F	E	Cx	Gx
6	1/4	-U-ML6-FL4	41.0(1.61)	15.3(0.60)	14.0(0.55)	14.0(0.55)	4.8(0.19)	15.2(0.60)	14.3(0.56)
8	1/4	-U-ML8-FL4	42.3(1.67)	16.2(0.64)	16.0(0.63)	15.0(0.59)	4.8(0.19)	15.2(0.60)	14.3(0.56)
8	3/8	-U-ML8-FL6	44.3(1.74)	16.2(0.64)	16.0(0.63)	16.0(0.63)	6.4(0.25)	16.8(0.66)	17.5(0.69)
10	1/4	-U-ML10-FL4	44.5(1.75)	17.2(0.68)	19.0(0.75)	18.0(0.71)	4.8(0.19)	15.2(0.60)	14.3(0.56)
10	3/8	-U-ML10-FL6	45.9(1.81)	17.2(0.68)	19.0(0.75)	18.0(0.71)	7.1(0.28)	16.8(0.66)	17.5(0.69)
12	3/8	-U-ML12-FL6	48.4(1.91)	22.8(0.90)	22.0(0.87)	22.0(0.87)	7.1(0.28)	16.8(0.66)	17.5(0.69)
12	1/2	-U-ML12-FL8	51.2(2.02)	22.8(0.90)	22.0(0.87)	22.0(0.87)	9.5(0.37)	22.9(0.90)	22.2(0.87)



Reducing Unions

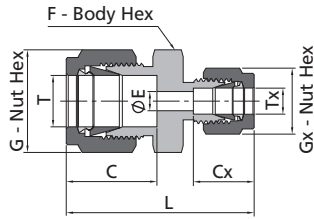

Fractional Tube			Dimension, in. (mm)						
T-Tube O.D. (in.)	Tx-Tube O.D. (in.)	Basic Ordering Number	L	C	G	F	E	Cx	Gx
3/8	1/4	-U-FL6-FL4	1.70(43.2)	0.66(16.8)	0.69(17.5)	0.63(15.9)	0.19(4.8)	0.60(15.2)	0.56(14.3)
1/2	1/4	-U-FL8-FL4	1.85(47.0)	0.90(22.8)	0.87(22.2)	0.81(20.6)	0.19(4.8)	0.60(15.2)	0.56(14.3)
1/2	3/8	-U-FL8-FL6	1.91(48.5)	0.90(22.8)	0.87(22.2)	0.81(20.6)	0.28(7.1)	0.66(16.8)	0.69(17.5)

Metric Tube			Dimension, mm (in.)						
T-Tube O.D. (mm)	Tx-Tube O.D. (mm)	Basic Ordering Number	L	C	G	F	E	Cx	Gx
8	6	-U-ML8-ML6	42.3(1.67)	16.3(0.64)	16.0(0.63)	15.0(0.59)	4.8(0.19)	15.3(0.60)	14.0(0.55)
10	8	-U-ML10-ML8	45.1(1.78)	17.2(0.68)	19.0(0.75)	18.0(0.71)	6.4(0.25)	16.3(0.64)	16.0(0.63)
12	10	-U-ML12-ML10	48.7(1.92)	22.8(0.90)	22.0(0.87)	22.0(0.87)	7.9(0.31)	17.2(0.68)	19.0(0.75)

Male Elbows

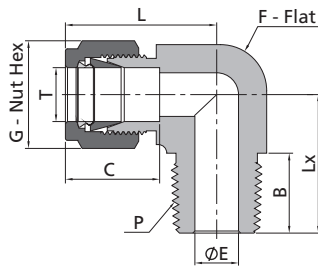

Fractional Tube			NPT Thread						
T-Tube O.D. (in.)	P-NPT Size	Basic Ordering Number	Dimension, in. (mm)						
			L	C	G	F	E	B	Lx
1/4	1/4	-LM-FL4-NS4	1.06(26.9)	0.60(15.2)	0.56(14.3)	0.50(12.7)	0.19(4.8)	0.56(14.2)	0.92(23.4)
3/8	3/8	-LM-FL6-NS6	1.23(31.2)	0.66(16.8)	0.69(17.5)	0.69(17.5)	0.28(7.1)	0.56(14.2)	1.03(26.2)
1/2	1/2	-LM-FL8-NS8	1.42(36.1)	0.90(22.9)	0.87(22.2)	0.81(20.6)	0.41(10.4)	0.75(19.1)	1.30(33.0)

Metric Tube			NPT Thread						
T-Tube O.D. (mm)	P-NPT Size	Basic Ordering Number	Dimension, mm (in.)						
			L	C	G	F	E	B	Lx
6	1/4	-LM-ML6-NS4	27.0(1.06)	15.3(0.60)	14.0(0.55)	12.7(0.50)	4.8(0.19)	14.2(0.56)	23.4(0.92)
8	3/8	-LM-ML8-NS6	30.6(1.20)	16.2(0.64)	16.0(0.63)	17.5(0.69)	6.4(0.25)	14.2(0.56)	26.2(1.03)
10	3/8	-LM-ML10-NS6	31.5(1.24)	17.2(0.68)	19.0(0.75)	17.5(0.69)	7.9(0.31)	14.2(0.56)	26.2(1.03)
12	1/2	-LM-ML12-NS8	36.0(1.42)	22.8(0.90)	22.0(0.87)	20.6(0.81)	9.5(0.37)	19.1(0.75)	33.0(1.30)

# Metal Flexible Hoses

## MH, MM Series

### Features

- ⦿ Core tube and fitting material: 316 SS
- ⦿ Overbraid material: 304 SS
- ⦿ For vacuum and positive pressure applications
- ⦿ Maximum working pressure: 3100 psig (213 bar)
- ⦿ Hose size: 1/4" to 1"
- ⦿ Temperature: -325°F to 800°F (-200°C to 426°C)
- ⦿ End connections:
  - 1/8 to 1 thread
  - 3/16" to 1" and 6 mm to 22 mm tube fitting
- ⦿ Welded fitting-to-hose construction to ensure reliable seal
- ⦿ Standard and custom length available

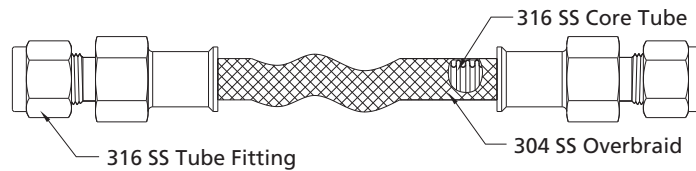

### Hose Technical Data (MH Series)

Nominal Hose Size	Inside Diameter	Min. Bend Radius		Temperature Range	Working Pressure @ 70°F (20°C)	Burst Pressure @ 70°F (20°C)	Hose Series
		Static	Dynamic				
in. (mm)	in. (mm)	in. (mm)	in. (mm)	°F (°C)	psig (bar)	psig (bar)	
1/4 (6.4)	0.28 (7.1)	2.25 (57.2)	10.0 (254)	-325 to 800 (-200 to 426)	3100 (213)	12400 (854)	MH4
3/8 (9.7)	0.42 (10.6)	3.00 (76.2)	12.0 (305)		2000 (137)	8000 (551)	MH6
1/2 (12.7)	0.53 (13.5)	4.50 (114)	16.0 (406)		1800 (124)	7200 (496)	MH8
3/4 (19.0)	0.80 (20.3)	6.00 (152)	17.0 (432)		1500 (103)	6000 (413)	MH12
1 (25.4)	1.03 (26.0)	6.75 (171)	20.0 (508)		1200 (82.6)	4800 (330)	MH16

### Hose Technical Data (MM Series)

Nominal Hose Size	Inside Diameter	Min. Bend Radius		Temperature Range	Working Pressure @ 70°F (20°C)	Burst Pressure @ 70°F (20°C)	Hose Series
		Static	Dynamic				
in. (mm)	in. (mm)	in. (mm)	in. (mm)	°F (°C)	psig (bar)	psig (bar)	
1/4 (6.4)	0.25 (6.4)	0.75 (19.0)	4.33 (110)	-325 to 800 (-200 to 426)	1600 (110)	6400 (440)	MM4
3/8 (9.7)	0.38 (9.5)	0.87 (22.1)	5.91 (150)		1470 (101)	6000 (413)	MM6
1/2 (12.7)	0.50 (12.7)	1.04 (26.4)	6.50 (165)		1110 (76.4)	4500 (310)	MM8
3/4 (19.0)	0.75 (19.0)	1.61 (40.9)	8.86 (225)		860 (59.2)	3500 (241)	MM12
1 (25.4)	1.00 (25.4)	1.89 (48.0)	10.2 (259)		680 (46.8)	2680 (184)	MM16

# Cylinder Connections



CGA DISS Series

B-16

CGA Series

B-20

DIN Series

B-27

Gas Connection Assignment Table

B-28

## Features

- ⦿ 100% visual inspection of critical surfaces
- ⦿ Diverse material and configurations available
- ⦿ Silver-plated nut threads to reduce installation torque
- ⦿ Every fitting marked with size, material and heat number
- ⦿ Cleaned and packaged for Oxygen and Ultra High Purity Service available
- ⦿ Customized solutions available

## Material

Series	Component	Material	Designator
CGA DISS	Nipples	316L SS	6L
	Nuts	304 SS	S4
	Gaskets	Nickel 200	NI
		PCTFE	K
		Aluminum	AL
	Plugs	316L SS	6L
	Adapters	316L SS	6L
Caps	316L SS	6L	
CGA DIN	Nipples	316L SS	6L
	Nuts	304 SS	S4
	Gaskets	PTFE	T
		PCTFE	K
	Plugs, Caps	316L SS	6L
Adapters	316L SS	6L	

**Notes:**

1. Nickel gasket heat treated; surface hardness < HB 100
2. 316L SS in compliance with SEMI F20

## Ordering information

- ⦿ Add material designator as a prefix to the basic ordering number to get the complete ordering number.  
Example: 6L-C634-L-FR4
- ⦿ CGA, DIN Series  
PTFE is standard material for gasket. If PCTFE is required, please add a suffix of "-k" to the ordering number.  
Example: 6L-C350-NS4-K
- ⦿ CGA DISS Series  
Nickel is standard material for gasket. If PCTFE is required, please add a suffix of "-k" to the ordering number.  
Example: 6L-C632-FR4-K

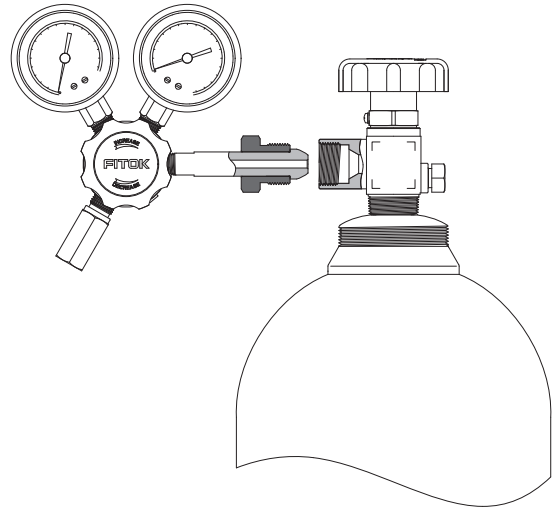

# CGA DISS Series

- ⦿ Non-rotating design
- ⦿ For nipples with TB or FR connections, inner surface electropolished to an average of Ra 9 µm. (0.23 µm); Ra 16 µm. (0.4 µm) for nipples with NPT connections
- ⦿ Nipples with TB or FR connections cleaned for Ultra High Purity Service and packaged in a Class 100 clean room; Nipples with NPT connections packaged and cleaned for Oxygen service
- ⦿ Maximum allowable leak rate:  $1 \times 10^{-9}$  mbar·l/s

## Cylinder Connections (Including Nipples, Nuts and Gaskets)

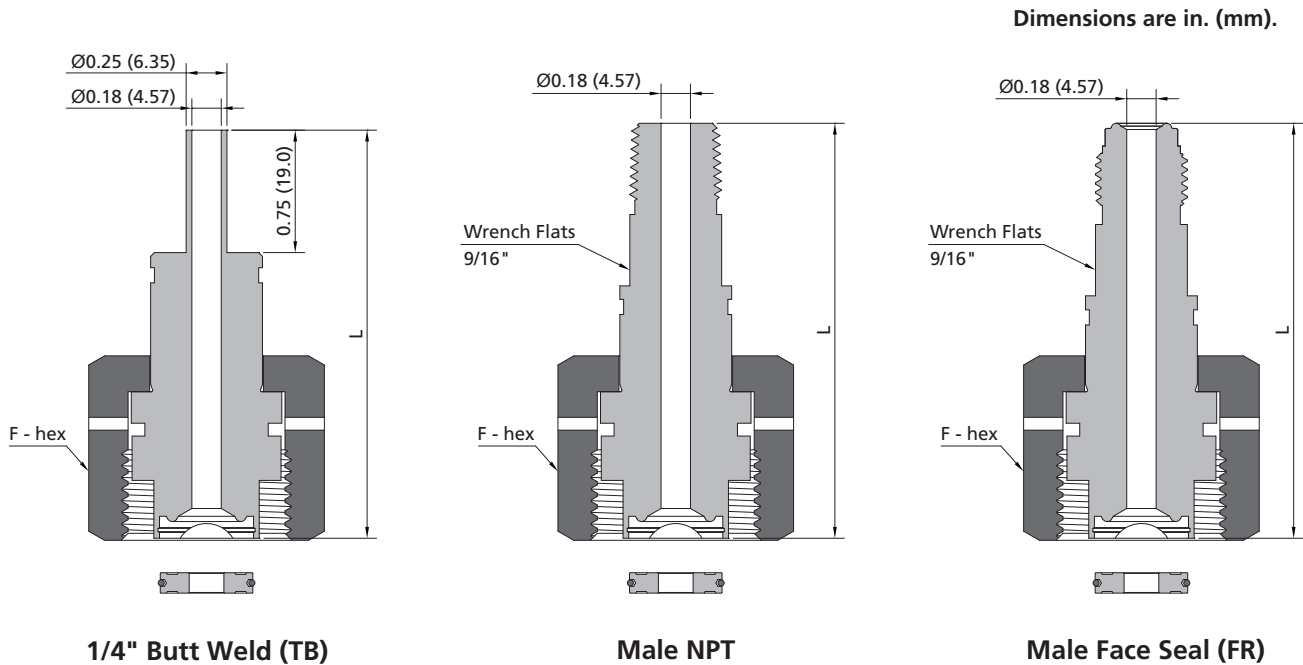

CGA Number	End Connection	Assembly Basic Ordering Number	Nipple Basic Ordering Number	Nut Basic Ordering Number	Gasket Basic Ordering Number	Dimensions, in. (mm)	
						L	F
632	1/4" TB	-C632-TB4	-C632-L-TB4	-C630-N	-C630-GT	2.5 (63.5)	1 1/4 (31.8)
	1/4" FR	-C632-FR4	-C632-L-FR4			3 (76.2)	1 1/4 (31.8)
	1/4" NPT	-C632-NS4	-C632-L-NS4			3 (76.2)	1 1/4 (31.8)
634	1/4" TB	-C634-TB4	-C634-L-TB4	-C630-N	-C630-GT	2.5 (63.5)	1 1/4 (31.8)
	1/4" FR	-C634-FR4	-C634-L-FR4			3 (76.2)	1 1/4 (31.8)
	1/4" NPT	-C634-NS4	-C634-L-NS4			3 (76.2)	1 1/4 (31.8)
636	1/4" TB	-C636-TB4	-C636-L-TB4	-C630-N	-C630-GT	2.5 (63.5)	1 1/4 (31.8)
	1/4" FR	-C636-FR4	-C636-L-FR4			3 (76.2)	1 1/4 (31.8)
	1/4" NPT	-C636-NS4	-C636-L-NS4			3 (76.2)	1 1/4 (31.8)
638	1/4" TB	-C638-TB4	-C638-L-TB4	-C630-N	-C630-GT	2.5 (63.5)	1 1/4 (31.8)
	1/4" FR	-C638-FR4	-C638-L-FR4			3 (76.2)	1 1/4 (31.8)
	1/4" NPT	-C638-NS4	-C638-L-NS4			3 (76.2)	1 1/4 (31.8)

CGA Number	End Connection	Assembly Basic Ordering Number	Nipple Basic Ordering Number	Nut Basic Ordering Number	Gasket Basic Ordering Number	Dimensions, in. (mm)	
						L	F
640	1/4" TB	-C640-TB4	-C640-L-TB4	-C630-N	-C630-GT	2.5 (63.5)	1 1/4 (31.8)
	1/4" FR	-C640-FR4	-C640-L-FR4			3 (76.2)	1 1/4 (31.8)
	1/4" NPT	-C640-NS4	-C640-L-NS4			3 (76.2)	1 1/4 (31.8)
642	1/4" TB	-C642-TB4	-C642-L-TB4	-C630-N	-C630-GT	2.5 (63.5)	1 1/4 (31.8)
	1/4" FR	-C642-FR4	-C642-L-FR4			3 (76.2)	1 1/4 (31.8)
	1/4" NPT	-C642-NS4	-C642-L-NS4			3 (76.2)	1 1/4 (31.8)
712	1/4" TB	-C712-TB4	-C712-L-TB4	-C710-N	-C630-GT	2.5 (63.5)	1 3/8 (34.9)
	1/4" FR	-C712-FR4	-C712-L-FR4			3 (76.2)	1 3/8 (34.9)
	1/4" NPT	-C712-NS4	-C712-L-NS4			3 (76.2)	1 3/8 (34.9)
714	1/4" TB	-C714-TB4	-C714-L-TB4	-C710-N	-C630-GT	2.5 (63.5)	1 3/8 (34.9)
	1/4" FR	-C714-FR4	-C714-L-FR4			3 (76.2)	1 3/8 (34.9)
	1/4" NPT	-C714-NS4	-C714-L-NS4			3 (76.2)	1 3/8 (34.9)
716	1/4" TB	-C716-TB4	-C716-L-TB4	-C710-N	-C630-GT	2.5 (63.5)	1 3/8 (34.9)
	1/4" FR	-C716-FR4	-C716-L-FR4			3 (76.2)	1 3/8 (34.9)
	1/4" NPT	-C716-NS4	-C716-L-NS4			3 (76.2)	1 3/8 (34.9)
718	1/4" TB	-C718-TB4	-C718-L-TB4	-C710-N	-C630-GT	2.5 (63.5)	1 3/8 (34.9)
	1/4" FR	-C718-FR4	-C718-L-FR4			3 (76.2)	1 3/8 (34.9)
	1/4" NPT	-C718-NS4	-C718-L-NS4			3 (76.2)	1 3/8 (34.9)
720	1/4" TB	-C720-TB4	-C720-L-TB4	-C720-N	-C630-GT	2.5 (63.5)	1 3/8 (34.9)
	1/4" FR	-C720-FR4	-C720-L-FR4			3 (76.2)	1 3/8 (34.9)
	1/4" NPT	-C720-NS4	-C720-L-NS4			3 (76.2)	1 3/8 (34.9)
722	1/4" TB	-C722-TB4	-C722-L-TB4	-C720-N	-C630-GT	2.5 (63.5)	1 3/8 (34.9)
	1/4" FR	-C722-FR4	-C722-L-FR4			3 (76.2)	1 3/8 (34.9)
	1/4" NPT	-C722-NS4	-C722-L-NS4			3 (76.2)	1 3/8 (34.9)
724	1/4" TB	-C724-TB4	-C724-L-TB4	-C720-N	-C630-GT	2.5 (63.5)	1 3/8 (34.9)
	1/4" FR	-C724-FR4	-C724-L-FR4			3 (76.2)	1 3/8 (34.9)
	1/4" NPT	-C724-NS4	-C724-L-NS4			3 (76.2)	1 3/8 (34.9)
726	1/4" TB	-C726-TB4	-C726-L-TB4	-C720-N	-C630-GT	2.5 (63.5)	1 3/8 (34.9)
	1/4" FR	-C726-FR4	-C726-L-FR4			3 (76.2)	1 3/8 (34.9)
	1/4" NPT	-C726-NS4	-C726-L-NS4			3 (76.2)	1 3/8 (34.9)
728	1/4" TB	-C728-TB4	-C728-L-TB4	-C720-N	-C630-GT	2.5 (63.5)	1 3/8 (34.9)
	1/4" FR	-C728-FR4	-C728-L-FR4			3 (76.2)	1 3/8 (34.9)
	1/4" NPT	-C728-NS4	-C728-L-NS4			3 (76.2)	1 3/8 (34.9)

Note:  
 Nickel is standard material for gasket. If PCTFE is required, please add a suffix of "-k" to the ordering number.  
 Example: 6L-C638-TB4-K

## Gaskets

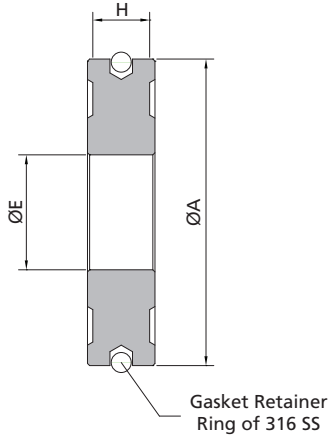

CGA Number	Gasket Ordering Number	Material	Dimensions					
			A		E		H	
			in.	mm	in.	mm	in.	mm
632~728	NI-C630-GT	Nickel 200	0.56	14.3	0.21	5.4	0.105	2.7
	K-C630-GT	PCTFE	0.56	14.3	0.21	5.4	0.125	3.2
	AL-C630-GT	Aluminum	0.56	14.3	0.21	5.4	0.105	2.7

## Outlet Adaptors

Female NPT

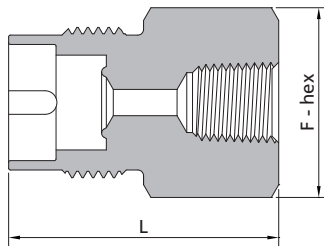

Male Face Seal (FR)

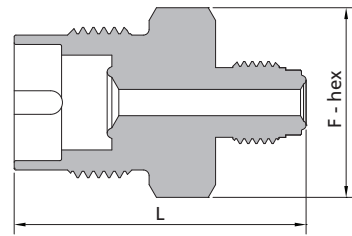

CGA Number	Basic Ordering Number	Dimensions, in. (mm)	
		L	F
632	-C632-A-FNS4	1.85 (47.0)	1 1/8 (28.6)
634	-C634-A-FNS4	1.85 (47.0)	1 1/8 (28.6)
636	-C636-A-FNS4	1.85 (47.0)	1 1/8 (28.6)
638	-C638-A-FNS4	1.85 (47.0)	1 1/8 (28.6)
640	-C640-A-FNS4	1.85 (47.0)	1 1/8 (28.6)
642	-C642-A-FNS4	1.85 (47.0)	1 1/8 (28.6)
712	-C712-A-FNS4	1.85 (47.0)	1 1/4 (31.8)
714	-C714-A-FNS4	1.85 (47.0)	1 1/4 (31.8)
716	-C716-A-FNS4	1.85 (47.0)	1 1/4 (31.8)
718	-C718-A-FNS4	1.85 (47.0)	1 1/4 (31.8)
720	-C720-A-FNS4	1.85 (47.0)	1 1/4 (31.8)
722	-C722-A-FNS4	1.85 (47.0)	1 1/4 (31.8)
724	-C724-A-FNS4	1.85 (47.0)	1 1/4 (31.8)
726	-C726-A-FNS4	1.85 (47.0)	1 1/4 (31.8)
728	-C728-A-FNS4	1.85 (47.0)	1 1/4 (31.8)

CGA Number	Basic Ordering Number	Dimensions, in. (mm)	
		L	F
632	-C632-A-FR4	2.0 (50.8)	1 1/8 (28.6)
634	-C634-A-FR4	2.0 (50.8)	1 1/8 (28.6)
636	-C636-A-FR4	2.0 (50.8)	1 1/8 (28.6)
638	-C638-A-FR4	2.0 (50.8)	1 1/8 (28.6)
640	-C640-A-FR4	2.0 (50.8)	1 1/8 (28.6)
642	-C642-A-FR4	2.0 (50.8)	1 1/8 (28.6)
712	-C712-A-FR4	2.0 (50.8)	1 1/4 (31.8)
714	-C714-A-FR4	2.0 (50.8)	1 1/4 (31.8)
716	-C716-A-FR4	2.0 (50.8)	1 1/4 (31.8)
718	-C718-A-FR4	2.0 (50.8)	1 1/4 (31.8)
720	-C720-A-FR4	2.0 (50.8)	1 1/4 (31.8)
722	-C722-A-FR4	2.0 (50.8)	1 1/4 (31.8)
724	-C724-A-FR4	2.0 (50.8)	1 1/4 (31.8)
726	-C726-A-FR4	2.0 (50.8)	1 1/4 (31.8)
728	-C728-A-FR4	2.0 (50.8)	1 1/4 (31.8)

## Blank Plugs

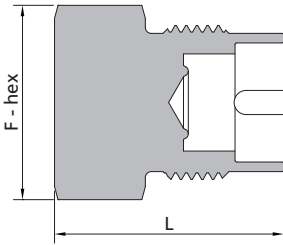

CGA Number	Basic Ordering Number	Dimensions, in. (mm)	
		L	F
632	-C632-BP	1.53 (38.9)	1 1/8 (28.6)
634	-C634-BP	1.53 (38.9)	1 1/8 (28.6)
636	-C636-BP	1.53 (38.9)	1 1/8 (28.6)
638	-C638-BP	1.53 (38.9)	1 1/8 (28.6)
640	-C640-BP	1.53 (38.9)	1 1/8 (28.6)
642	-C642-BP	1.53 (38.9)	1 1/8 (28.6)
712	-C712-BP	1.53 (38.9)	1 1/4 (31.8)
714	-C714-BP	1.53 (38.9)	1 1/4 (31.8)
716	-C716-BP	1.53 (38.9)	1 1/4 (31.8)
718	-C718-BP	1.53 (38.9)	1 1/4 (31.8)
720	-C720-BP	1.53 (38.9)	1 1/4 (31.8)
722	-C722-BP	1.53 (38.9)	1 1/4 (31.8)
724	-C724-BP	1.53 (38.9)	1 1/4 (31.8)
726	-C726-BP	1.53 (38.9)	1 1/4 (31.8)
728	-C728-BP	1.53 (38.9)	1 1/4 (31.8)

## Valve Outlet Caps (Including Chains, Rings and Gaskets)

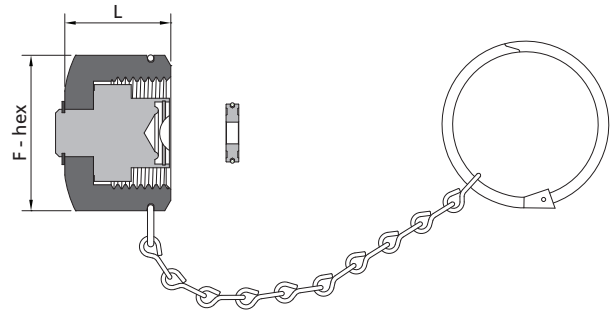

CGA Number	Basic Ordering Number	Dimensions, in. (mm)	
		L	F
632	-C632-CP	0.98 (24.9)	1 1/4 (31.8)
634	-C634-CP	0.98 (24.9)	1 1/4 (31.8)
636	-C636-CP	0.98 (24.9)	1 1/4 (31.8)
638	-C638-CP	0.98 (24.9)	1 1/4 (31.8)
640	-C640-CP	0.98 (24.9)	1 1/4 (31.8)
642	-C642-CP	0.98 (24.9)	1 1/4 (31.8)
712	-C712-CP	0.98 (24.9)	1 3/8 (34.9)
714	-C714-CP	0.98 (24.9)	1 3/8 (34.9)
716	-C716-CP	0.98 (24.9)	1 3/8 (34.9)
718	-C718-CP	0.98 (24.9)	1 3/8 (34.9)
720	-C720-CP	0.98 (24.9)	1 3/8 (34.9)
722	-C722-CP	0.98 (24.9)	1 3/8 (34.9)
724	-C724-CP	0.98 (24.9)	1 3/8 (34.9)
726	-C726-CP	0.98 (24.9)	1 3/8 (34.9)
728	-C728-CP	0.98 (24.9)	1 3/8 (34.9)

Note:  
 Nickel is standard material for gasket. If PCTFE is required, please add a suffix of "-k" to the ordering number.  
 Example: 6L-C632-CP-K



# CGA Series

- ⦿ CGA V-1-2005 compliant
- ⦿ For nipples with TB or FR connections, inner surface electropolished to an average of Ra 9 µin. (0.23 µm); Ra 32 µin. (0.8 µm) for nipples with NPT connections
- ⦿ Cleaned and packaged for Oxygen service
- ⦿ Maximum allowable leak rate: 1 x 10<sup>-9</sup> mbar·l/s

## Cylinder Connections (Including Nipples, Nuts and Gaskets)

Dimensions are in. (mm).

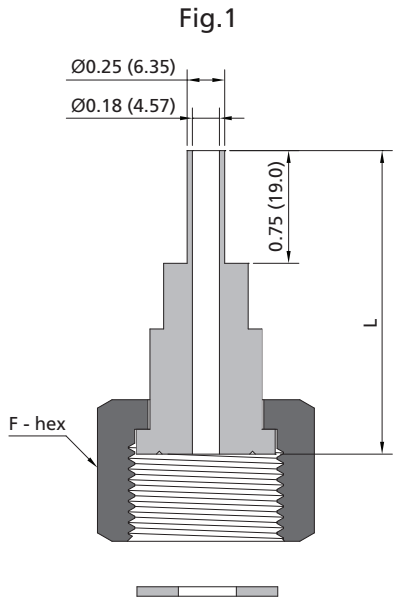

1/4" Butt Weld (TB)

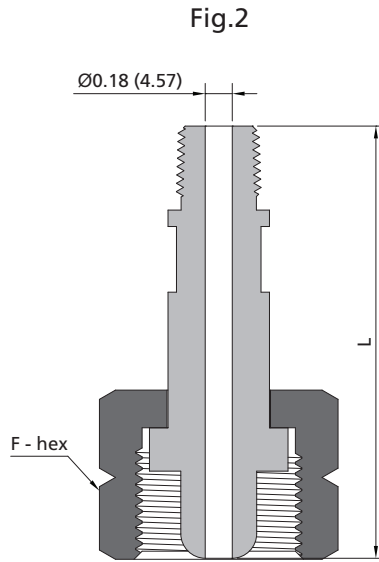

Male NPT

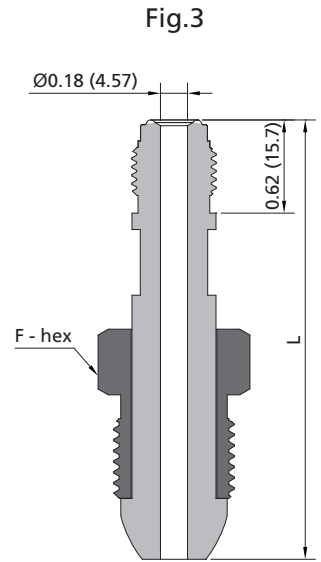

Male Face Seal (FR)

CGA Number	Ref. Fig.	End Connection	Assembly Basic Ordering Number	Nipple Basic Ordering Number	Nut Basic Ordering Number	Gasket Basic Ordering Number	Dimensions, in. (mm)	
							L	F
170	Fig. 1	1/4" TB	-C170-TB4	-C170-L-TB4	-C170-N	-C170-GT	1.25 (31.8)	11/16 (17.5)
		1/8" NPT	-C170-NS2	-C170-L-NS2				
180	Fig. 1	1/4" TB	-C180-TB4	-C180-L-TB4	-C180-N	-C180-GT	1.25 (31.8)	3/4 (19.1)
		1/8" NPT	-C180-NS2	-C180-L-NS2				
290	Fig. 2	1/4" TB	-C290-TB4	-C290-L-TB4	-C290-N	—	2.63 (66.7)	1 (25.4)
		1/4" NPT	-C290-NS4	-C290-L-NS4				
296	Fig. 3	1/4" TB	-C296-TB4	-C296-L-TB4	-C296-N	—	2.63 (66.7)	7/8 (22.3)
		1/4" NPT	-C296-NS4	-C296-L-NS4				
		1/4" FR	-C296-FR4	-C296-L-FR4				
320	Fig. 1	1/4" TB	-C320-TB4	-C320-L-TB4	-C320-N	-C320-GT	1.75 (44.5)	1 1/8 (28.6)
		1/4" NPT	-C320-NS4	-C320-L-NS4				
		1/4" FR	-C320-FR4	-C320-L-FR4				

CGA Number	Ref. Fig.	End Connection	Assembly Basic Ordering Number	Nipple Basic Ordering Number	Nut Basic Ordering Number	Gasket Basic Ordering Number	Dimensions, in. (mm)	
							L	F
326	Fig.2	1/4" TB	-C326-TB4	-C326-L-TB4	-C326-N	—	2.25 (57.2)	1 1/8 (28.6)
		1/4" NPT	-C326-NS4	-C326-L-NS4			3.0 (76.2)	
		1/4" FR	-C326-FR4	-C326-L-FR4			2.25 (57.2)	
330	Fig.1	1/4" TB	-C330-TB4	-C320-L-TB4	-C330-N	-C320-GT	1.75 (44.5)	1 1/8 (28.6)
		1/4" NPT	-C330-NS4	-C320-L-NS4			2.5 (63.5)	
		1/4" FR	-C330-FR4	-C320-L-FR4			1.75 (44.5)	
346	Fig.2	1/4" TB	-C346-TB4	-C346-L-TB4	-C346-N	—	2.31 (58.7)	1 1/8 (28.6)
		1/4" NPT	-C346-NS4	-C346-L-NS4			3.0 (76.2)	
		1/4" FR	-C346-FR4	-C346-L-FR4			2.25 (57.2)	
350	Fig.2	1/4" TB	-C350-TB4	-C350-L-TB4	-C350-N	—	2.31 (58.7)	1 1/8 (28.6)
		1/4" NPT	-C350-NS4	-C350-L-NS4			3.0 (76.2)	
		1/4" FR	-C350-FR4	-C350-L-FR4			2.25 (57.2)	
510	Fig.3	1/4" TB	-C510-TB4	-C510-L-TB4	-C510-N	—	2.63 (66.7)	1 1/8 (28.6)
		1/4" NPT	-C510-NS4	-C510-L-NS4			3.5 (88.9)	
		1/4" FR	-C510-FR4	-C510-L-FR4			2.75 (69.9)	
540 <sup>Ⓞ</sup>	Fig.2	1/4" TB	-C540-TB4	-C540-L-TB4	-C540-N	—	2.25 (57.2)	1 1/8 (28.6)
		1/4" NPT	-C540-NS4	-C540-L-NS4			3.0 (76.2)	
		1/4" FR	-C540-FR4	-C540-L-FR4			2.25 (57.2)	
580	Fig.3	1/4" TB	-C580-TB4	-C510-L-TB4	-C580-N	—	2.63 (66.7)	1 1/8 (28.6)
		1/4" NPT	-C580-NS4	-C510-L-NS4			3.5 (88.9)	
		1/4" FR	-C580-FR4	-C510-L-FR4			2.75 (69.9)	
590	Fig.3	1/4" TB	-C590-TB4	-C510-L-TB4	-C590-N	—	2.63 (66.7)	1 1/8 (28.6)
		1/4" NPT	-C590-NS4	-C510-L-NS4			3.5 (88.9)	
		1/4" FR	-C590-FR4	-C510-L-FR4			2.75 (69.9)	
660	Fig.1	1/4" TB	-C660-TB4	-C660-L-TB4	-C660-N	-C660-GT	2.19 (55.6)	1 1/4 (31.8)
		1/4" NPT	-C660-NS4	-C660-L-NS4			2.5 (63.5)	
		1/4" FR	-C660-FR4	-C660-L-FR4			1.88 (47.6)	
670	Fig.1	1/4" TB	-C670-TB4	-C660-L-TB4	-C670-N	-C660-GT	2.19 (55.6)	1 1/4 (31.8)
		1/4" NPT	-C670-NS4	-C660-L-NS4			2.5 (63.5)	
		1/4" FR	-C670-FR4	-C660-L-FR4			1.88 (47.6)	
678	Fig.1	1/4" TB	-C678-TB4	-C678-L-TB4	-C678-N	-C678-GT	2.5 (63.5)	1 1/4 (31.8)
		1/4" NPT	-C678-NS4	-C678-L-NS4			2.5 (63.5)	
		1/4" FR	-C678-FR4	-C678-L-FR4			2.0 (50.8)	
679	Fig.1	1/4" TB	-C679-TB4	-C679-L-TB4	-C679-N	-C679-GT	2.5 (63.5)	1 1/4 (31.8)
		1/4" NPT	-C679-NS4	-C679-L-NS4			3.0 (76.2)	
		1/4" FR	-C679-FR4	-C679-L-FR4			2.0 (50.8)	

Ⓞ Cleaned and packaged for Oxygen Service.

Note:  
 PTFE is standard material for gasket. If PCTFE is required, please add a suffix of "-k" to the ordering number.  
 Example: 6L-C170-FR4-K

## Gaskets

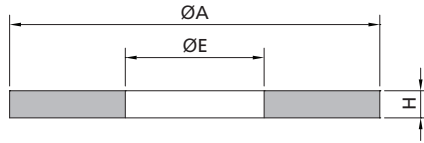

CGA Number	Gasket Basic Ordering Number	Dimensions					
		A		E		H	
		in.	mm	in.	mm	in.	mm
170	-C170-GT	0.43	11.0	0.19	4.8	0.10	2.5
180	-C180-GT	0.44	11.2	0.32	8.1	0.09	2.3
320, 330	-C320-GT	0.72	18.3	0.26	6.6	0.09	2.3
660, 670	-C660-GT	0.94	23.9	0.38	9.7	0.06	1.6
678	-C678-GT	0.61	15.5	0.30	7.6	0.06	1.6
679	-C679-GT	0.53	13.5	0.31	7.9	0.06	1.6

# Outlet Adaptors, Blank Caps and Plugs

## Blank Caps CGA 580

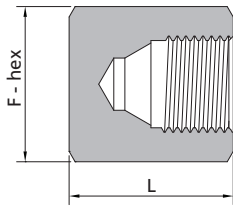

## Blank Plugs CGA 350

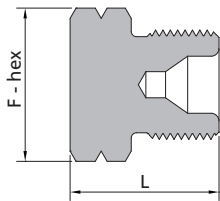

## Male Face Seal (FR) CGA 350

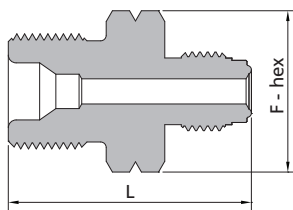

## Female NPT CGA 350

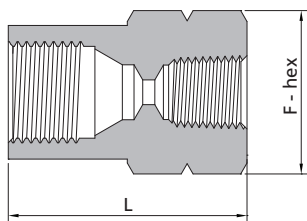

CGA Number	End Connection	Assembly Basic Ordering Number	Dimensions, in. (mm)	
			L	F
180	1/4" Female NPT	-C180-A-FNS4	1.38 (35.0)	3/4 (19.1)
296	Blank Cap	-C296-BC	1.37 (34.8)	1 1/8 (28.6)
	1/4" Female NPT	-C296-A-FNS4	2.0 (50.8)	
320	1/4" FR	-C296-A-FR4	2.0 (50.8)	1 (25.4)
	Blank Plug	-C320-BP	1.12 (28.4)	
	1/4" Female NPT	-C320-A-FNS4	1.12 (28.4)	
326	1/4" FR	-C320-A-FR4	1.74 (44.2)	1 (25.4)
	Blank Plug	-C326-BP	1.12 (28.4)	
	1/4" Female NPT	-C326-A-FNS4	1.31 (33.3)	
330	1/4" FR	-C326-A-FR4	1.74 (44.2)	1 (25.4)
	Blank Plug	-C330-BP	1.12 (28.4)	
	1/4" Female NPT	-C330-A-FNS4	1.31 (33.3)	
346	1/4" FR	-C330-A-FR4	1.74 (44.2)	1 (25.4)
	Blank Plug	-C346-BP	1.12 (28.4)	
	1/4" Female NPT	-C346-A-FNS4	1.31 (33.3)	
350	1/4" FR	-C346-A-FR4	1.88 (47.8)	1 (25.4)
	Blank Plug	-C350-BP	1.12 (28.4)	
	1/4" Female NPT	-C350-A-FNS4	1.31 (33.3)	
510	1/4" FR	-C350-A-FR4	1.88 (47.8)	1 (25.4)
	Blank Cap	-C510-BC	1.37 (34.8)	
	1/4" Female NPT	-C510-A-FNS4	2.0 (50.8)	
540 <sup>Ⓞ</sup>	1/4" FR	-C510-A-FR4	2.0 (50.8)	1 1/4 (31.8)
	Blank Plug	-C540-BP	1.12 (28.4)	
	1/4" Female NPT	-C540-A-FNS4	1.25 (31.8)	
580	1/4" FR	-C540-A-FR4	1.87 (47.5)	1 (25.4)
	Blank Cap	-C580-BC	1.37 (34.8)	
	1/4" Female NPT	-C580-A-FNS4	2.0 (50.8)	
580	1/4" FR	-C580-A-FR4	2.0 (50.8)	1 1/4 (31.8)

Ⓞ Cleaned and packaged for Oxygen Service.

**Female NPT**

CGA 350

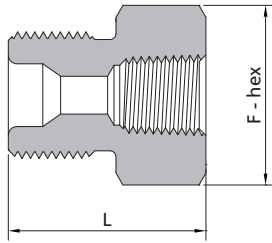

CGA Number	End Connection	Assembly Basic Ordering Number	Dimensions, in. (mm)	
			L	F
590	Blank Cap	-C590-BC	1.37 (34.8)	1 1/4 (31.8)
	1/4" Female NPT	-C590-A-FNS4	2.0 (50.8)	
	1/4" FR	-C590-A-FR4	2.0 (50.8)	
660	Blank Plug	-C660-BP	0.88 (22.4)	1 1/8 (28.6)
	1/4" Female NPT	-C660-A-FNS4	1.25 (31.8)	
	1/4" FR	-C660-A-FR4	1.5 (38.1)	
670	Blank Plug	-C670-BP	0.88 (22.4)	1 1/8 (28.6)
	1/4" Female NPT	-C670-A-FNS4	1.25 (31.8)	
	1/4" FR	-C670-A-FR4	1.5 (38.1)	
678	Blank Plug	-C678-BP	1.0 (25.4)	1 1/8 (28.6)
	1/4" Female NPT	-C678-A-FNS4	1.38 (35.1)	
	1/4" FR	-C678-A-FR4	1.5 (38.1)	
679	Blank Plug	-C679-BP	0.88 (22.4)	1 1/8 (28.6)
	1/4" Female NPT	-C679-A-FNS4	1.25 (31.8)	
	1/4" FR	-C679-A-FR4	1.75 (44.5)	

**Cylinder Valve Outlet Plugs**

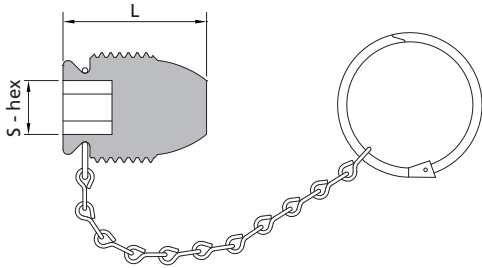

CGA Number	Basic Ordering Number	Dimensions, in. (mm)	
		L	S
510	-C510-PG	1.0 (25.4)	3/8 (9.5)
580	-C580-PG	1.0 (25.4)	
590	-C590-PG	1.0 (25.4)	

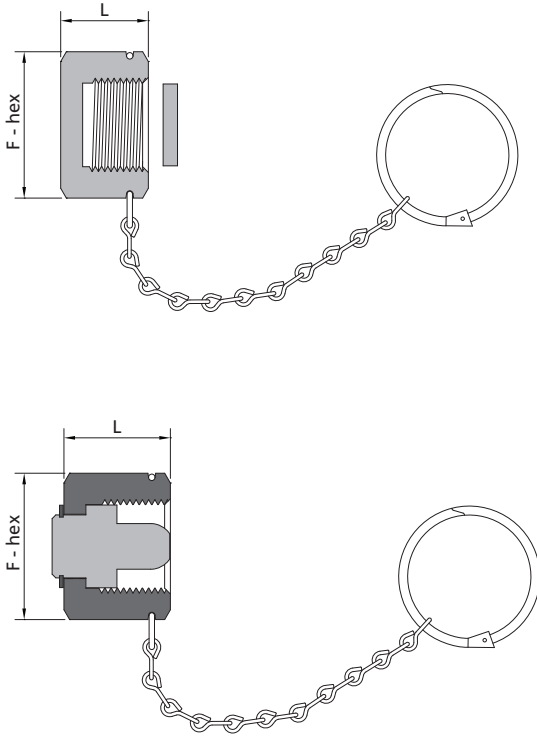

CGA Number	Basic Ordering Number	Dimensions, in. (mm)	
		L	F
320	-C320-CP	0.54 (13.7)	1 (25.4)
326	-C320-CP	0.54 (13.7)	
330	-C330-CP	0.54 (13.7)	
346	-C320-CP	0.54 (13.7)	
660	-C660-CP	0.54 (13.7)	1 1/4 (31.8)
670	-C670-CP	0.54 (13.7)	
678	-C670-CP	0.54 (13.7)	
679	-C670-CP	0.54 (13.7)	

Notes:

1. PTFE is standard material for gasket. If PCTFE is required, please add a suffix of "-k" to the ordering number.  
Example: S4-C330-CP-K
2. The caps listed above are only intended to keep valve outlets clean and protect its threads. They shouldn't be used to contain pressure if the valve leaks or is opened by mistake.

CGA Number	Basic Ordering Number	Dimensions, in. (mm)	
		L	F
350	-C350-CP	0.82 (20.8)	1 1/8 (28.6)

## Complete Pigtail Connections (Including Nipples, Nuts, Gaskets and Blank Plugs or Caps)

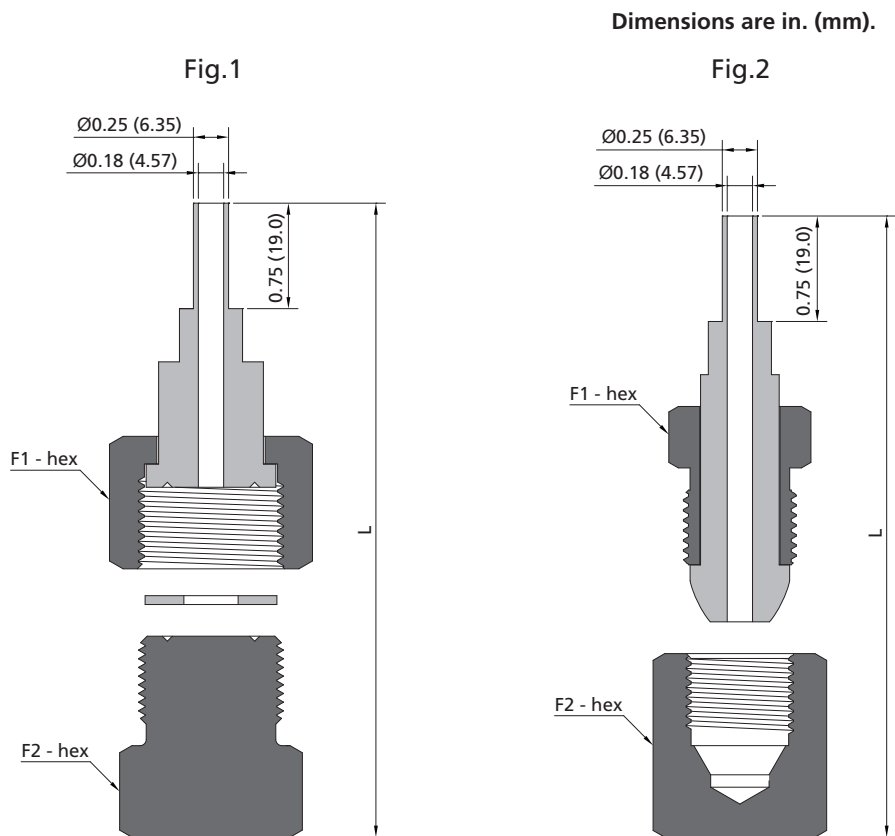

CGA Number	Ref. Fig.	Assembly Basic Ordering Number	Gasket Basic Ordering Number	Dimensions, in. (mm)		
				L	F1	F2
296	Fig.2	-C296-TB4-A	—	3.03 (77.0)	7/8 (22.3)	1 1/8 (28.6)
320	Fig.1	-C320-TB4-A	-C320-GT	2.96 (75.2)	1 1/8 (28.6)	1 (25.4)
326	Fig.1	-C326-TB4-A	—	3.01 (76.5)		
330	Fig.1	-C330-TB4-A	-C320-GT	2.96 (75.2)		
346	Fig.1	-C346-TB4-A	—	2.97 (75.4)		
350	Fig.1	-C350-TB4-A	—	2.96 (75.2)		
510	Fig.2	-C510-TB4-A	—	3.03 (77.0)		1 1/4 (31.8)
540 <sup>①</sup>	Fig.1	-C540-TB4-A	—	2.96 (75.2)		1 (25.4)
580	Fig.2	-C580-TB4-A	—	3.03 (77.0)		1 1/4 (31.8)
590	Fig.2	-C590-TB4-A	—	3.03 (77.0)		
660	Fig.1	-C660-TB4-A	-C660-GT	2.96 (75.2)		1 1/4 (31.8)
670	Fig.1	-C670-TB4-A	-C660-GT	2.96 (75.2)		
678	Fig.1	-C678-TB4-A	-C678-GT	3.08 (78.2)		
679	Fig.1	-C679-TB4-A	-C679-GT	2.96 (75.2)		

① Cleaned and packaged for Oxygen Service.

**Note:**

PTFE is standard material for gasket. If PCTFE is required, please add a suffix of "-k" to the ordering number.

Example: 6L-C330-TB4-A-K

## Assembly Torque For CGA Cylinder Connections

CGA NO.	Recommended Torque		CGA NO.	Recommended Torque	
	ft-lb	N·m		ft-lb	N·m
170 <sup>①</sup>	10~15	14~20	510	35~50	47~68
180 <sup>①</sup>	10~15	14~20	540	40~60	54~81
290	30~45	41~61	580	40~60	54~81
296	35~50	47~68	590	40~60	54~81
320 <sup>①</sup>	20~30	27~41	660 <sup>①</sup>	30~45	41~61
326	25~35	34~47	670 <sup>①</sup>	30~45	41~61
330 <sup>①</sup>	20~30	27~41	678 <sup>①</sup>	25~35	34~47
346	35~50	47~68	679 <sup>①</sup>	25~35	34~47
350	35~50	47~68			
CGA DISS NO.	Recommended Torque		Gasket Material		
	ft-lb	N·m			
632-728	35~40	47~53.8	Nickel		
	12~15	16~20.1	PCTFE		

① Gasket for seal: PTFE or PCTFE.

# DIN Series

- ⦿ DIN 477-1 compliant
- ⦿ For nipples with TB or FR connections, inner surface electropolished to an average of Ra 9 µin. (0.23 µm); Ra 32 µin. (0.8 µm) for nipples with NPT connections
- ⦿ Cleaned and packaged for Oxygen service
- ⦿ Maximum allowable leak rate: 1 x 10<sup>-9</sup> mbar·l/s

## Complete Pigtail Connections (Including Nipples, Nuts, Gaskets and Blank Plugs)

Dimensions are in. (mm).

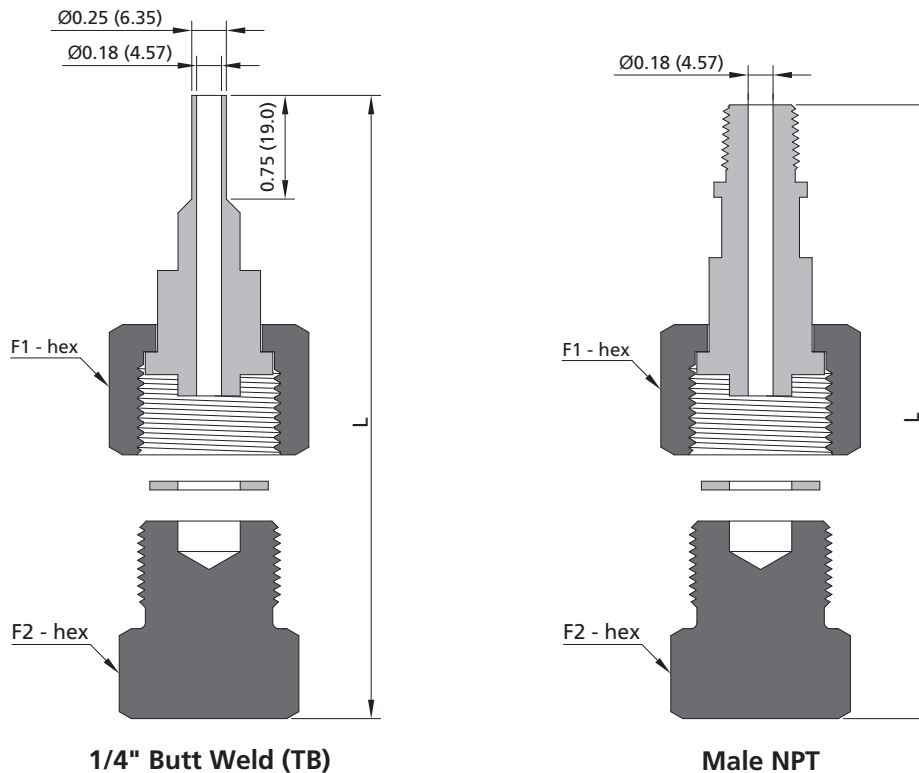

DIN Number	Assembly Basic Ordering Number	Gasket Basic Ordering Number	Dimensions, in.(mm)				
			L	F1	F2		
1	-DIN1-TB4-A	-DIN1-GT	2.96 (75.2)	1 1/4 (31.8)	1 1/4 (31.8)		
	-DIN1-NS4-A		4.25 (108)				
5	-DIN5-TB4-A	-DIN5-GT	3.09 (78.5)				
	-DIN5-NS4-A		4.41 (112)				
6	-DIN6-TB4-A	-DIN1-GT	2.96 (75.2)				
	-DIN6-NS4-A		4.25 (108)				
8	-DIN8-TB4-A	-DIN5-GT	3.09 (78.5)				
	-DIN8-NS4-A		4.41 (112)				
11	-DIN11-TB4-A	-DIN11-GT	2.88 (73.2)			7/8 (22.3)	11/16 (17.5)
	-DIN11-NS4-A		4.14 (105.2)				
14	-DIN14-TB4-A		4.15 (105.5)	1 1/16 (27.0)	7/8 (22.3)		
	-DIN14-NS4-A						

Notes:  
 1. Above components can be ordered separately.  
 2. PTFE is standard material for gasket. If PCTFE is required, please add a suffix of "-k" to the ordering number.  
 Example: 6L-D1N1-TB4-A-K



# Gas Connection Assignment Table<sup>®</sup>

GAS	Formula	UHP CGA	CGA	DIN	JIS
Ammonia	NH <sub>3</sub>	720	705	DIN6	22-R
Argon	Ar	718	580	DIN6	22-R or 23-R
Arsenic Pentafluoride	AsF <sub>5</sub>	642	—	—	—
Arsine	AsH <sub>3</sub>	632	350	—	22-L
Boron Trichloride	BCl <sub>3</sub>	634	660	DIN8	—
Boron Trifluoride	BF <sub>3</sub>	642	330	DIN8	22-L
Carbon Dioxide	CO <sub>2</sub>	716	320	DIN6	—
Carbon Monoxide	CO	724	350	DIN5	22-L
Chlorine	Cl <sub>2</sub>	728	—	DIN8	26-R
Diborane	B <sub>2</sub> H <sub>6</sub>	632	350	—	22-L
Dichlorosilane	SiH <sub>2</sub> Cl <sub>2</sub>	636	678 <sup>①</sup>	DIN5	—
Diethylzinc	Zn(C <sub>2</sub> H <sub>5</sub> ) <sub>2</sub>	726	510 <sup>②</sup>	—	—
Diethyltelluride	(C <sub>2</sub> H <sub>5</sub> ) <sub>2</sub> Te	726	—	—	—
Dimethylzinc	(CH <sub>3</sub> ) <sub>2</sub> Zn	726	—	—	—
Disilane	Si <sub>2</sub> H <sub>6</sub>	632	—	—	—
Germane	GeH <sub>4</sub>	632	350 or 660	—	—
Halocarbon 11	CCl <sub>3</sub> F	716	660	—	—
Halocarbon 115	ClCF <sub>2</sub> CF <sub>3</sub>	716	660	DIN6	—
Halocarbon 12	CCl <sub>2</sub> F <sub>2</sub>	716	660	DIN6	—
Halocarbon 13	ClCF <sub>3</sub>	716	660	DIN6	—
Halocarbon 14	CF <sub>4</sub>	716	320 or 580	DIN6	—
Halocarbon 23	CHF <sub>3</sub>	716	660	DIN6	—
Halocarbon 116	F <sub>3</sub> CCF <sub>3</sub>	716	660	—	—
Helium	He	718	580	DIN6	22-R or 23-R
Hydrogen	H <sub>2</sub>	724	350	DIN1	22-L
Hydrogen Bromide	HBr	634	330	DIN8	26-R
Hydrogen Chloride	HCl	634	330	DIN8	26-R
Hydrogen Fluoride	HF	638	660 or 670	—	26-R
Hydrogen Sulfide	H <sub>2</sub> S	722	330	DIN5	—
Krypton	Kr	718	580	DIN6	22-R or 23-R
Neon	Ne	718	580	DIN6	22-R or 23-R
Nitrogen	N <sub>2</sub>	718	580	DIN10	22-R or 23-R
Nitrogen Trifluoride	NF <sub>3</sub>	640	330 or 670	DIN8	—
Nitrous Oxide	N <sub>2</sub> O	712	326	DIN8	—
Oxygen	O <sub>2</sub>	714	540	DIN9	22-R or 23-R
Perfluoropropane	CF <sub>2</sub> (CF <sub>3</sub> )	716	660	—	—
Phosphine	PH <sub>3</sub>	632	350 or 660	DIN1	—
Phosphorus Pentafluoride	PF <sub>5</sub>	642	330 or 660	—	—
Silane	SiH <sub>4</sub>	632	350	—	—
Silicon Tetrachloride	SiCl <sub>4</sub>	636	—	—	—
Silicon Tetrafluoride	SiF <sub>4</sub>	642	330	—	22-L
Sulphur Hexafluoride	SF <sub>6</sub>	716	590	DIN6	26-R
Trichlorosilane	SiHCl <sub>3</sub>	636	—	—	—
Triethylaluminum	(C <sub>2</sub> H <sub>5</sub> ) <sub>3</sub> Al	726	510 <sup>②</sup>	—	—
Tungsten Hexafluoride	WF <sub>6</sub>	638	670	DIN8	—
Xenon	Xe	718	580	DIN6	22-R

① Refer to CGA organization specification for pressure limits.

② Information in this table is for reference only.

# C

## Technical References

Common Terms and Definitions . . . . .	C-02
Gas Purity Values . . . . .	C-03
How to Use the FITOK Flow Charts . . . . .	C-04
Conversion Factors . . . . .	C-05
Material Compatibility for Gases . . . . .	C-06
Ordering Details for Specialty Gas Equipment . . . . .	C-08

# Common Terms and Definitions

## Inlet Pressure

The pressure of media of gas or liquid on the inlet port of the regulator or valve;  
Typical units of measure: psig, bar and MPa.

## Outlet Pressure

The pressure of media of gas or liquid on the outlet port of the regulator or valve.

## Accuracy

The variation in control pressure which occurs under steady state conditions within the control range of a regulator.

## Sensitivity

The ability of a pressure regulator to respond to change in discharge conditions: pressure, flow, temperature, etc.

## Flow Coefficient (Cv)

A flow coefficient that is numerically equal to the number of U.S. Gallons of water at 60°F/16°C that will flow through a valve or regulator in one minute when the pressure differential between the inlet and outlet is 1 psi. When gas is used instead of liquid, the equation is modified to account for the use of a compressible fluid. For a regulator, Cv is determined when the regulator is wide open and not regulating. When determining flow performance use actual flow curves.

## Leakage - External

The loss of fluid from the external surfaces or joints of a regulator or valve. Example: From the body-bonnet-diaphragm joint. Leakage to atmosphere. The leakage rate is measured in mbar l/s Helium.

## Leakage - Internal

The loss of fluid through a regulator or valve, between pressure zones normally expected to be sealed. Example: Between the inlet pressure and the outlet pressure zones.

## Load Element

One of the three basic elements of a pressure reducing regulator. It provides the means by which the operator can set the force that determines the control pressure of a regulator. This element includes the spring and the stem.

## Sensing Element

One of the three basic elements of a pressure reducing regulator. It senses the changes of the outlet pressure and acts as a physical connection between the load element and control element.

## Control Element

One of the three basic elements of a pressure regulator to reduce the high inlet pressure to a stable lower outlet pressure by adjusting the orifice.

## Diaphragm

One type of sensing elements, which is sensitive in reacting to outlet pressure change, normally used for gas media. Common material include elastomeric and metallic.

## Piston

One type of sensing element. Used in high pressure regulators. Normally with O-ring seals.

## Unbalanced Main Valve

Inlet pressure provides the majority of the shutoff force. The function of the main valve is to reduce the high inlet pressure to a lower outlet pressure.

## Balanced Valve

A main valve designed to relieve the inlet force loading on the seat.

## Venting

When the load pressure is relieved, the vent valve shall be opened by the downstream force to vent the downstream pressure.

# Gas Purity Values

Type	Degree	Purity Value	Max. Contamination (ppm)
Pure	2.5	99.5%	5000
	3.0	99.9%	1000
High Purity	3.5	99.95%	500
	4.0	99.99%	100
	4.5	99.995%	50
	5.0	99.999%	10
	5.5	99.9995%	5
	6.0	99.9999%	1.0
Ultra High Purity	7.0	99.99999%	0.1

# How to Use the FITOK Flow Chart

A FITOK Flow Chart is a graphic representation of test results, in curves, showing the changes in outlet pressure of a regulator with the varying flow rate basing on different inlet pressures. The regulator is so designed that at the time the outlet pressure reaches the set pressure, the flow rate would be zero. The inlet pressure is indicated on the right end of each curve.

To use the FITOK Flow Charts, the first step is to select the chart that fits the following:

- Regulator model
- Expected flow range
- Inlet pressure range
- Outlet pressure range

Subsequently, select a curve, if available, plotted for the exact inlet pressure and set pressure of the outlet (zero flow). Locate the set pressure on the vertical axis. Follow the curve until it crosses the vertical line corresponding to the desired flow rate. Read horizontally from the cross point to the vertical axis to locate the actual working pressure for this flow rate. If no curve is plotted for the exact pressure, extrapolate a new curve between and referring to the two closest existing curves.

## Example:

Using the flow chart to determine the pressure drop (from the set pressure to the outlet pressure at 30 SCFM condition).

Given Conditions: Inlet pressure=3000 psig, Set pressure=2250 psig

Steps: 1. Locate the set pressure (2250 psig) with zero flow on the vertical axis;

2. Follow the curve until it crosses the vertical line corresponding to 30 SCFM;

3. Read horizontally from the cross point to the vertical axis. The corresponding pressure read is 1945 psig.

Therefore, the pressure drop is 305 psig.

## Flow Chart

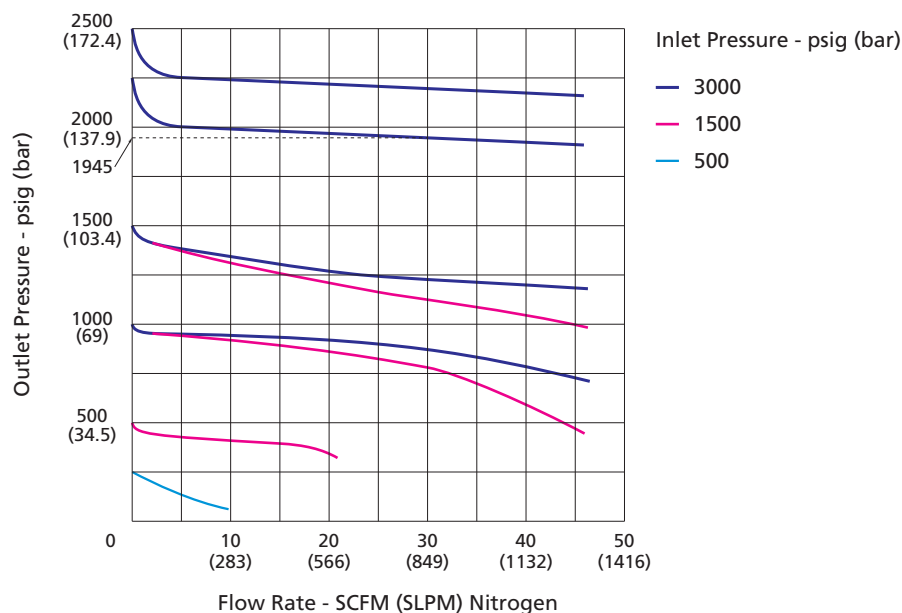

## Notes:

1. The performance of regulator is more accurate in the range where the curve is comparatively flat.
2. All test results on the FITOK Flow Charts are based on utilization of Nitrogen as a medium in standard testing conditions. Please contact FITOK for additional information.

# Conversion Factors

## Pressure

From \ To	psi	bar	atm	KPa	ft. of H <sub>2</sub> O	in. of H <sub>2</sub> O	mm of Hg	in. of Hg	Kg/cm <sup>2</sup>
psi	1	0.068948	0.06805	6.89465	2.3089	27.708	51.175	2.036	0.070307
bar	14.5038	1	0.98692	100	33.4883	401.8596	750.062	29.53	1.0197
atm	14.696	1.01325	1	101.3171	33.932	407.1827	760	29.921	1.0332
KPa	0.14504	0.010	0.00987	1	0.33456	4.01472	7.5006	0.29613	0.0102
ft. of H <sub>2</sub> O	0.433107	0.029891	0.02947	2.989	1	12	22.4198	0.882646	0.03048
in. of H <sub>2</sub> O	0.03609	0.002499	0.00246	0.0249089	0.08333	1	1.86832	0.073556	0.00254
mm of Hg	0.019337	0.001333	0.00132	0.133322	0.044603	0.535240	1	0.03937	0.00136
in. of Hg	0.49115	0.033864	0.03342	3.376895	1.134	13.6	25.4	1	0.034532
Kg/cm <sup>2</sup>	14.22334	0.980665	0.9678	98.03922	32.8084	393.7008	735.5592	28.95903	1

## Flow

From \ To	cm <sup>3</sup> /min	cm <sup>3</sup> /sec	ft <sup>3</sup> /hr	ft <sup>3</sup> /min	m <sup>3</sup> /hr	m <sup>3</sup> /min	L/hr	L/min
cm <sup>3</sup> /min	1	0.0166667	0.0021189	0.0000353	0.00006	0.000001	0.06	0.001
cm <sup>3</sup> /sec	60	1	0.127134	0.0021189	0.0036	0.00006	3.6	0.06
ft <sup>3</sup> /hr	471.9474	7.86579	1	0.0166667	0.0283168	0.0004719	28.31685	0.4719474
ft <sup>3</sup> /min	28316.85	471.9474	60	1	1.699008	0.0283168	1699.008	28.31686
m <sup>3</sup> /hr	16666.67	277.7778	35.31467	0.5885777	1	0.0166667	1000	16.66667
m <sup>3</sup> /min	1000000	16666.67	2118.876	35.31467	60	1	60000	1000
L/hr	16.66667	0.2777778	0.0353147	0.0005885	0.001	0.0000167	1	0.0166667
L/min	1000	16.66667	2.118876	0.0353147	0.06	0.001	60	1

## Density

From \ To	gms/cm <sup>3</sup>	kg/m <sup>3</sup>	lbs/ft <sup>3</sup>	lbs/in <sup>3</sup>	lbs/U.S. gal
gms/cm <sup>3</sup>	1	1000	62.428	0.0361273	8.3454
kg/m <sup>3</sup>	0.001	1	0.062428	3.61273×10 <sup>-5</sup>	0.0083454
lbs/ft <sup>3</sup>	0.0160185	16.018463	1	5.78704×10 <sup>-4</sup>	0.13368
lbs/in <sup>3</sup>	27.679905	27679.9	1728	1	231
lbs/U.S. gal	0.1198264	119.8264	7.4805195	0.004329	1

# Material Compatibility for Gases

Material Media	Metals						Plastics				Elastomers	
	Copper	Brass	Aluminum	SS	Hastelloy C 22	Monel	PCTFE	Teflon PTFE	PEEK	VespeI	Viton	Buna-N
Acetylene	3	2	1	1	1	1	1	1	4	4	1	1
Ammonia	3	3	2	1	1	1	1	1	4	3	3	2
Argon	1	1	1	1	1	1	1	1	1	1	1	1
Argon/Methane	1	1	1	1	1	1	1	1	1	1	1	1
Arsine	3	2	3	1	1	1	1	1	4	4	1	4
Boron Trichloride	3	3	3	2	1	1	1	1	4	4	4	3
Boron Trifluoride	3	3	3	2	1	1	1	1	4	4	4	3
N-Butane	1	1	1	1	1	1	1	1	1	1	1	1
Carbon Dioxide	1	1	1	1	1	1	1	1	1	1	1	1
Carbon Monoxide	1	1	1	1	1	1	1	1	4	4	1	1
Chlorine	3	3	3	2	1	1	1	1	4	2	1	3
Deuterium	1	1	1	1	1	1	1	1	1	1	1	1
Diborane	1	1	1	1	1	1	1	1	1	1	1	3
Ethane	1	1	1	1	1	1	1	1	1	1	1	1
Ethylene	1	1	1	1	1	1	1	1	1	1	1	1
Fluorine	2	3	2	3	3	1	2	1	3	3	3	3
Hydrogen	1	1	1	1	1	1	1	1	1	1	1	1
Hydrogen Chloride	3	3	3	2	1	1	1	1	4	2	2	3
Hydrogen Fluoride	3	3	3	3	2	1	1	1	4	4	4	3
Hydrogen Sulphide	3	3	3	1	1	4	4	4	4	4	1	4
Hydrogen Iodide	3	3	3	4	4	4	4	4	4	4	4	4
Helium	1	1	1	1	1	1	1	1	1	1	1	1
Hexafluoro Ethane	1	1	1	1	1	1	2	1	4	4	4	4

## Codes

- 1 Recommended
- 2 Use with Limitations
- 3 Not Applicable
- 4 Insufficient Data

Material  Media	Metals						Plastics				Elastomers	
	Copper	Brass	Aluminum	SS	Hastelloy C 22	Monel	PCTFE	Teflon PTFE	PEEK	Vespel	Viton	Buna-N
Isobutene	1	1	1	1	1	1	1	1	1	1	1	1
Isobutane	1	1	1	1	1	1	1	1	1	1	1	1
Krypton	1	1	1	1	1	1	1	1	1	1	1	1
Methane	1	1	1	1	1	1	1	1	1	1	1	1
Methyl Chloride	4	4	3	1	1	4	4	1	4	4	1	3
Methyl Mercaptan	3	2	1	1	4	4	1	1	4	4	4	4
Neon	1	1	1	1	1	1	1	1	1	1	1	1
Nitrogen	1	1	1	1	1	1	1	1	1	1	1	1
Nitrous Oxide	1	1	1	1	1	1	2	1	1	1	1	1
Nitrogen Dioxide	4	2	2	1	4	2	1	1	4	4	4	4
Nitrogen Trifluoride	2	4	4	2	4	1	4	4	4	4	4	4
Nitrogen Monoxide	3	3	1	1	1	3	1	1	4	4	4	4
Phosphine	2	1	2	1	1	1	1	1	4	4	2	4
Propane	1	1	1	1	1	1	1	1	1	1	1	1
Propylene	1	1	1	1	1	1	1	1	1	1	1	3
Oxygen	1	1	1	1	1	1	1	1	1	1	1	1
Sulphur Dioxide	2	2	2	1	1	4	1	1	4	4	3	3
Sulphur Hexafluoride	1	1	1	1	1	1	1	1	1	1	1	1
Silane	1	1	1	1	1	1	1	1	4	4	1	4
Synthetic Air	1	1	1	1	1	1	1	1	1	1	1	1
Tetrafluoro Methane	1	1	1	1	1	1	1	1	4	4	1	4
Trifluoro Methane R23	1	1	1	1	1	1	1	1	4	4	4	4
Xenon	1	1	1	1	1	1	1	1	1	1	1	1

### Codes

- 1 Recommended
- 2 Use with Limitations
- 3 Not Applicable
- 4 Insufficient Data



# Ordering Details for Specialty Gas Equipment

Gas Control Equipment

Reladet Products

Technical References

<p><b>Company</b> _____</p> <p><b>Name</b> _____</p> <p><b>Tel</b> _____</p> <p><b>E-mail</b> _____</p>
<p><b>Application Information</b></p>
<p>Gas _____      Chemical formula _____      Purity _____</p> <p>Upstream pressure _____ psig, _____ bar, _____ Mpa</p> <p>Downstream pressure range _____ psig, _____ bar, _____ Mpa</p> <p>Temperature _____ °C _____ °F      Cv or flow rate _____</p> <p>Application _____</p> <p>_____</p>
<p><b>Pressure Regulator Data</b></p>
<p>Single-stage <input type="checkbox"/>      Dual-stage <input type="checkbox"/></p>
<p>Material (mostly gas type dependent):    Stainless Steel <input type="checkbox"/>      Brass <input type="checkbox"/>      Hastelloy <input type="checkbox"/></p>
<p><input type="radio"/> Cylinder pressure regulator <input type="checkbox"/></p> <p style="padding-left: 20px;">Cylinder connection    Yes <input type="checkbox"/>    No <input type="checkbox"/></p> <p style="padding-left: 20px;">Purge unit      Yes <input type="checkbox"/>    No <input type="checkbox"/></p> <p><input type="radio"/> Panel and line pressure regulator <input type="checkbox"/></p> <p style="padding-left: 20px;">2 ports <input type="checkbox"/>    3 ports <input type="checkbox"/>    4 ports <input type="checkbox"/></p> <p><input type="radio"/> Pressure control panel <input type="checkbox"/></p> <p style="padding-left: 20px;">Purge unit      Yes <input type="checkbox"/>    No <input type="checkbox"/></p> <p><input type="radio"/> Changeover system <input type="checkbox"/></p> <p style="padding-left: 20px;">With line regulator    Yes <input type="checkbox"/>    No <input type="checkbox"/></p> <p><input type="radio"/> Point-of-use panel <input type="checkbox"/></p>

# Integrated Gas System



**FITOK**

## Integrated Gas System

Integrated Gas System is a device used for gas control in the semiconductor industry. As semiconductor manufacturing processes become more advanced, the requirements for gas control device are also increasing. FITOK Integrated Gas System uses SEMI compliant surface-mounted components and is modularly designed. While reducing the size of the device, installation and maintenance become easier.

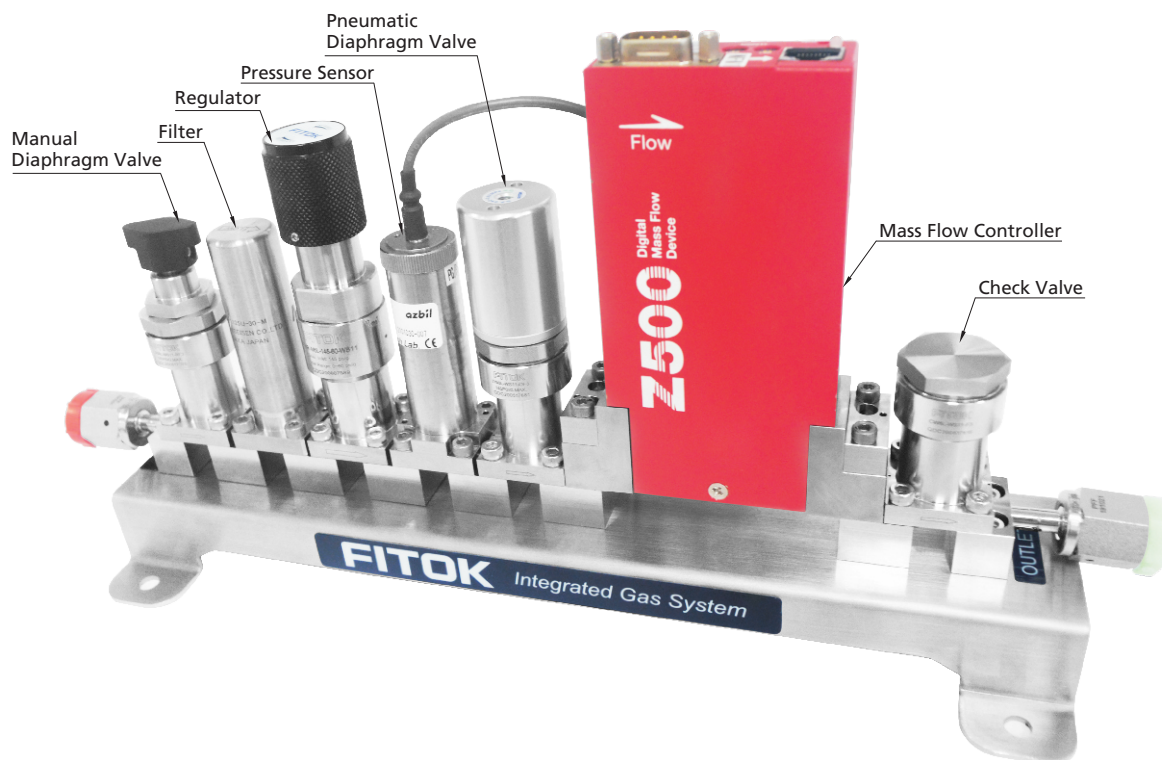

## Substrates

### Features

- ◎ 316L VIM-VAR
- ◎ Non-fixed installation to ensure the sealing effect
- ◎ The wetted parts are treated with EP, and the surface roughness does not exceed Ra 5  $\mu\text{m}$ . (0.13  $\mu\text{m}$ )

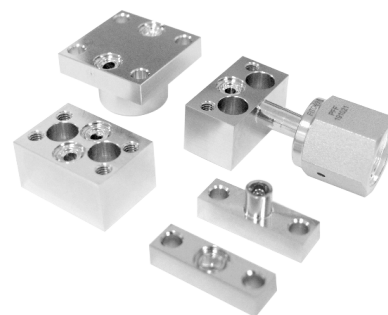

## W-seal Gaskets

### Features

- ◎ 316L VIM-VAR
- ◎ Sealing faces independent of components receiving external forces
- ◎ After EP treatment, the surface roughness does not exceed Ra 5  $\mu\text{m}$ . (0.13  $\mu\text{m}$ )



# Diaphragm Valves

## Features

- ◎ Body material: 316L VIM-VAR
- ◎ Elgiloy diaphragm improves strength and corrosion resistance
- ◎ 1.125" W-seal modular design
- ◎ No packing diaphragm seal ensures high purity
- ◎ No dead zone structure design of flow channel, easy to purge
- ◎ Pneumatic actuator optional
- ◎ The wetted parts are treated with EP, and the surface roughness does not exceed Ra 5 μin. (0.13 μm)



## Technical Data

Max. Working Pressure	Manual	145 psig (10 bar)
	Pneumatic	
Working Temperature	14°F~176°F (-10~80°C)	
Flow Coefficient (Cv)	0.2	
Actuator Working Pressure	60~90 psig (4.2~6.2 bar)	
Leak Rate	Internal	≤1x10 <sup>-9</sup> mbar l/s
	External	≤1x10 <sup>-9</sup> mbar l/s

## Dimensions and Ordering Information

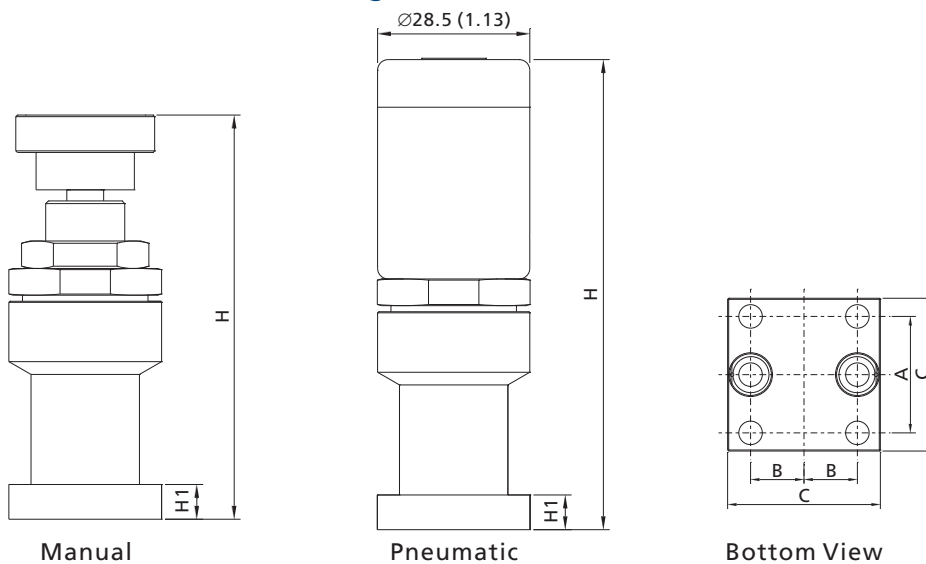

Ordering Number	Port Type and Size	Dimensions, in. (mm)				
		A	B	C	H	H1
DS6LW-WS11-CF3	1.125" W-seal	0.86 (21.8)	0.39 (10.0)	1.13 (28.6)	3.46 (88.0)	0.26 (6.5)
DS6LW-WS11-OF3	1.125" W-seal	0.86 (21.8)	0.39 (10.0)	1.13 (28.6)	3.46 (88.0)	0.26 (6.5)
DS6LW-WS11-RF3	1.125" W-seal	0.86 (21.8)	0.39 (10.0)	1.13 (28.6)	2.99 (76.0)	0.26 (6.5)

Note: For other materials and port types, please contact FITOK.

# Check Valves

## Features

- ⦿ Body material: 316L VIM-VAR
- ⦿ 1.125" W-seal modular design
- ⦿ The wetted parts are treated with EP, and the surface roughness does not exceed Ra 5 μm. (0.13 μm)



## Technical Data

<b>Max. Working Pressure</b>		145 psig (10 bar)
<b>Working Temperature</b>		14°F~176°F (-10~80°C)
<b>Flow Coefficient (Cv)</b>		0.2
<b>Cracking Pressure</b>		2.26 KPa
<b>Leak Rate</b>	<b>Internal</b>	≤1x10 <sup>-9</sup> mbar l/s
	<b>External</b>	≤1x10 <sup>-9</sup> mbar l/s

## Dimensions and Ordering Information

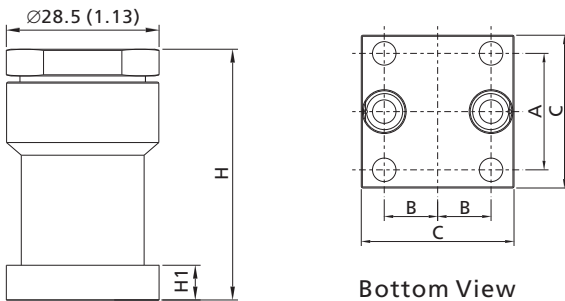

Ordering Number	Port Type and Size	Dimensions, in. (mm)				
		A	B	C	H	H1
CW6LW-WS11-F3	1.125" W-seal	0.86 (21.8)	0.39 (10.0)	1.13 (28.6)	1.85 (47.0)	0.26 (6.5)

Note: For other materials and port types, please contact FITOK.

# Regulators

## Features

- ⦿ Body material: 316L VIM-VAR
- ⦿ Hastelloy poppet and diaphragm
- ⦿ Metal-to-metal diaphragm seal design
- ⦿ 1.125" W-seal modular design
- ⦿ Reinforced diaphragm design improves sealing performance and service life
- ⦿ No springs and threads in the wetted zone, easy to purge
- ⦿ The wetted parts are treated with EP, and the surface roughness does not exceed Ra 5 μm. (0.13 μm)



## Technical Data

<b>Max. Working Pressure</b>		145 psig (10 bar)
<b>Working Temperature</b>		-40~160°F (-40~71°C)
<b>Outlet Pressure Range</b>		0~60 psig (0~4.1 bar)
<b>Flow Coefficient (Cv)</b>		0.06
<b>Leak Rate</b>	<b>Internal</b>	≤5x10 <sup>-8</sup> mbar l/s
	<b>External</b>	≤2x10 <sup>-9</sup> mbar l/s

## Dimensions and Ordering Information

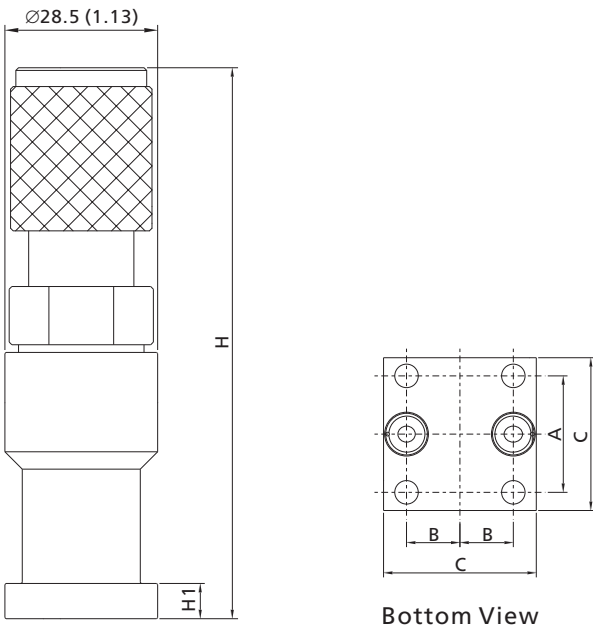

Ordering Number	Connection Type and Size	Dimensions, in. (mm)				
		A	B	C	H	H1
FHR-M6LW-145-60-WS11-F3	1.125" W-seal	0.86 (21.8)	0.39 (10.0)	1.13 (28.6)	4.10 (104.0)	0.27 (6.9)

Note: For other materials and port types, please contact FITOK.

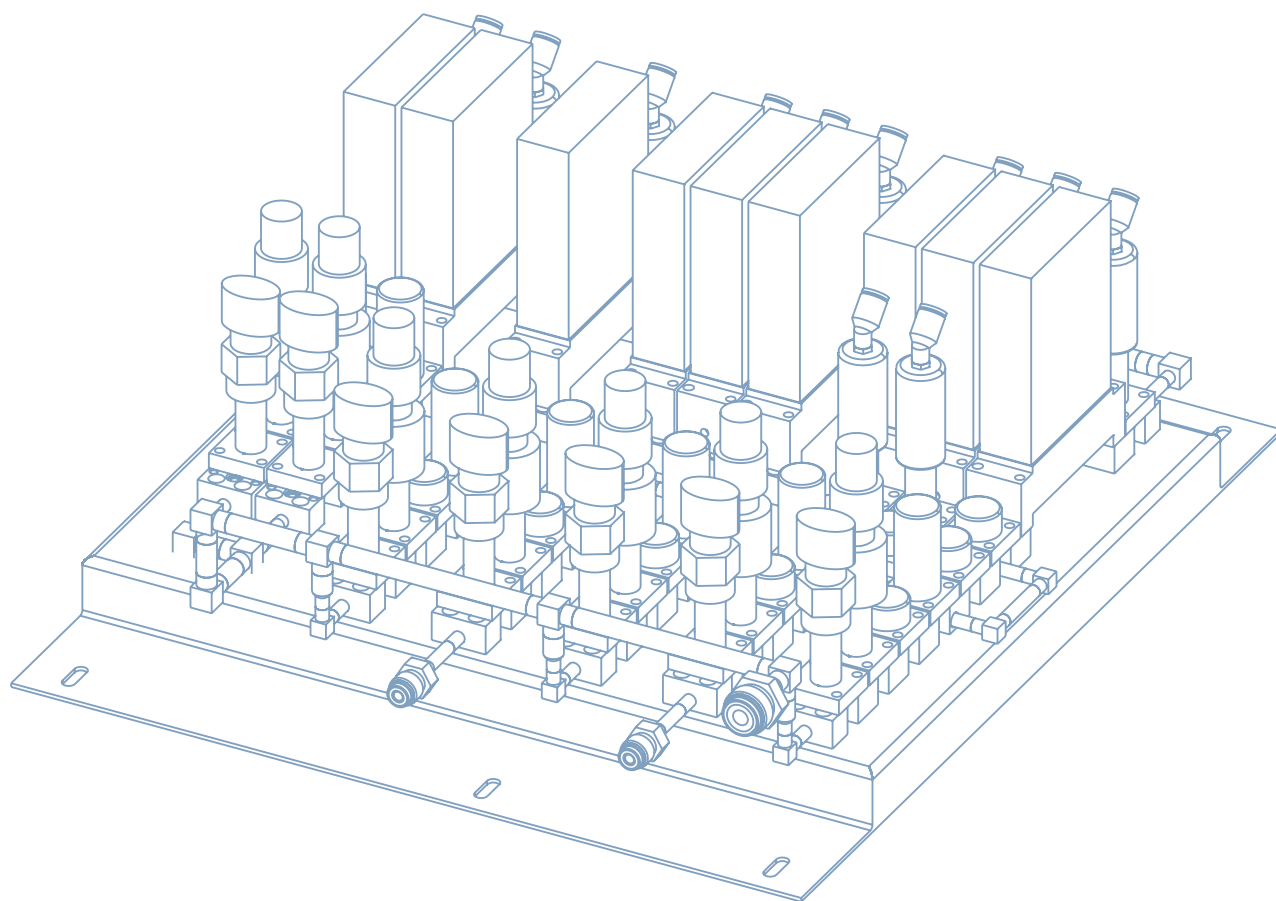

## FITOK Group

### FITOK GmbH

Sprendlinger Landstr. 115, 63069 Offenbach am Main,  
Germany  
Tel.: +49 69 8900 4498 Fax: +49 69 8900 4495

### FITOK (Wuhan) Incorporated

Zhongbai Yangluo Industrial Park, Hanshi Road,  
Xinzhou District, Wuhan 430415, China  
Tel.: +86 27 8983 8988 Fax: +86 27 8983 8980

### FITOK (Suzhou) Metal Products Co., Ltd.

No. 29 Changsheng Road, Yangyuan Industrial Park,  
Xinzhuang Town, Changshu, Jiangsu 215562, China  
Tel.: +86 512 5247 9001 Fax: +86 512 5247 9002

### FITOK, Inc.

13843 North Promenade Blvd., Suite 750, Stafford,  
Texas 77477, USA  
Tel.: +1 281 888 0077 Fax: +1 281 582 4051

### FITOK (Shenzhen) Incorporated

No.164 Xinqu Village, Tiantou Community, Shijing Street,  
Pingshan District, Shenzhen 518118, China  
Tel.: +86 755 2803 2500 Fax: +86 755 2803 2619

### FITOK Middle East Oil Equipment Trading LLC

Makateb Building, P.O. Box 185412, Airport Road, Deira,  
Dubai, UAE  
Tel.: +971 4 2959 853 Fax: +971 4 2959 854

info@fitokgroup.com  
www.fitokgroup.com



# Installation Instructions and Cautions

1. Before installing the pressure regulator, the pipeline must be purged to remove foreign matter and particles, such as remaining scrap iron from pipe cutting.



2. Filter must be installed upstream of the pressure regulator, otherwise system particles will damage the seat, causing internal leakage in the pressure regulator, increasing downstream pressure, and damaging the gauge or other equipment. FITOK FT series 15  $\mu\text{m}$  filter is recommended and poppet in-line replacement is available.

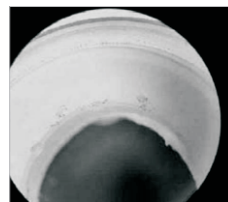

3. Thread adhesive or liquid tape is not recommended for NPT thread installation, otherwise the filter in the pressure regulator may be blocked, resulting in no pressure at the outlet.



4. Turn the handle clockwise to increase outlet pressure and counterclockwise to reduce outlet pressure. The regulator handle can be in loose state when the outlet pressure is zero. Forcefully loose the handle may cause the stem thread stuck, then turn the handle clockwise, the stem will not move and the handle will fall off, resulting in unable to adjust pressure.

5. It is not recommended to use the pressure regulator for shutoff for a long time, otherwise the seat will deform, resulting in flow instability.

6. Handle with care and avoid any strike, especially for pressure regulator with gauge. The gauge is a sensitive element and external force may cause damage.



# VPR Series Steam Heated Vaporizing Pressure Regulator

## Features

- ⦿ 316L SS or Alloy 400 body optional
- ⦿ Low internal volume
- ⦿ Convolved diaphragm design to improve regulation precision and cycle life
- ⦿ Good thermal conductivity saves energy and cost
- ⦿ With special cleaning and packaging, applicable to oxygen-enriched environments

## Technical Data

- ⦿ Maximum inlet pressure: 3600 psig (248.2 bar)
- ⦿ Outlet pressure range: 0~25 psig (0~1.7 bar), 0~50 psig (0~3.4 bar), 0~100 psig (0~6.9 bar), 0~250 psig (0~17.2 bar), 0~500 psig (0~34.5 bar)
- ⦿ Materials of the internal components:
  - Body: 316L SS or Alloy 400
  - Seat: PEEK
  - Diaphragm: Hastelloy
  - Poppet spring: Alloy X-750
  - Lift poppet: Hastelloy
- ⦿ Maximum vapor pressure and temperature: 600 psig (41 bar) and 500°F (260°C)
- ⦿ Medium working temperature: -40°F~+500°F (-40°C~+260°C)
- ⦿ Leak rates:
  - Internal  $\leq 1 \times 10^{-7}$  mbar l/s helium
  - External  $\leq 1 \times 10^{-7}$  mbar l/s helium
- ⦿ Flow coefficient (Cv): 0.06
- ⦿ Weight:  $\approx 5.5$  lbs (2.5 Kg)
- ⦿ Standard Connections: 1/4" female NPT for inlet and outlet port, 3/8" female NPT steam supply connections



## Typical Flow Chart

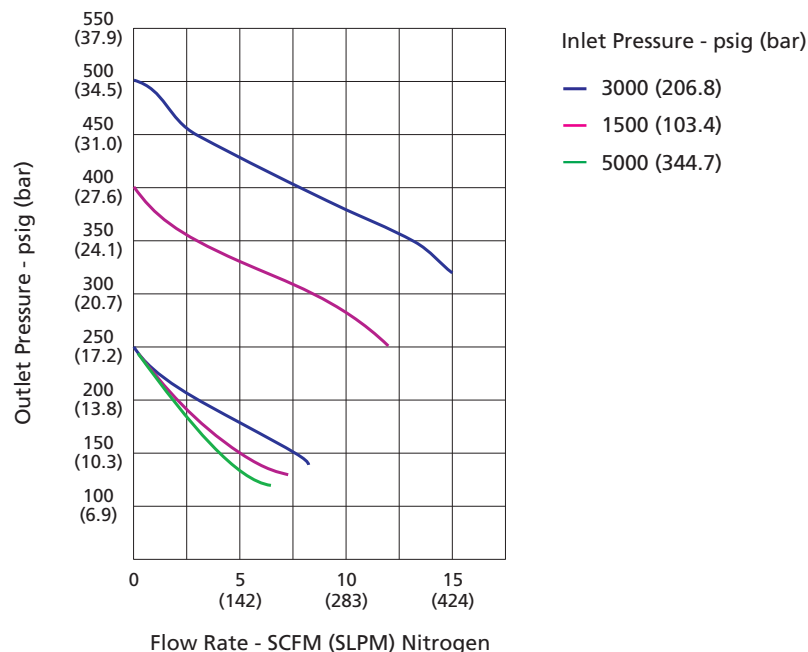



## Port Configuration

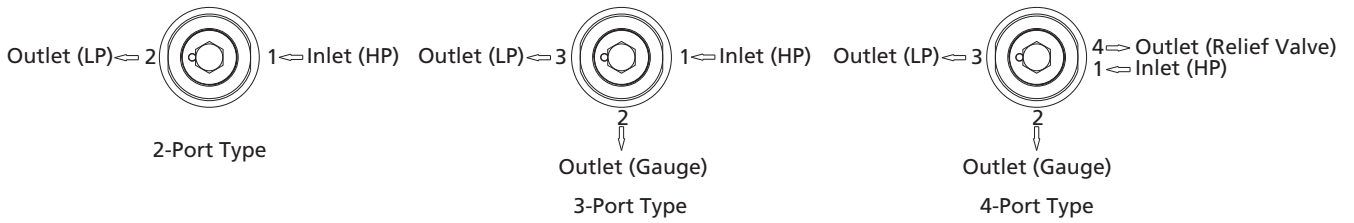

## Part Number Description

VPR - M - 36 - 100 - 00 - 00 - B - R

Body Material		Inlet Pressure P1 psig (bar)		Connection 1		Connection 2		Connection 3		Connection 4	
6L	316L SS	36	3600 (248.2)	00	1/4" Female NPT	B	With Gauge (psi/bar)	Same as Connection 1		Same as Connection 2	
M	Alloy 400	<b>Outlet Pressure Range P2 psig (bar)</b>		01	1/4" Male NPT	M	With Gauge (MPa)				
		25	0~25 (0~1.7)	10	1/4" Tube Fitting	R	Relief Valve				
		50	0~50 (0~3.4)	11	3/8" Tube Fitting	P	Plug				
		100	0~100 (0~6.9)	20	6 mm Tube Fitting	00	1/4" Female NPT				
		250	0~250 (0~17.2)	21	8 mm Tube Fitting	01	1/4" Male NPT				
		500	0~500 (0~34.5)	Other connections are available upon request		10	1/4" Tube Fitting				
						11	3/8" Tube Fitting				
						20	6 mm Tube Fitting				
						21	8 mm Tube Fitting				
						Other connections are available upon request					

Examples of part number:  
 a. 2-port type (1 in, 1 out): VPR-6L-36-50-00-00  
 b. 3-port type (1 in, 2 out): VPR-6L-36-100-00-B-00  
 c. 4-port type (1 in, 3 out): VPR-6L-36-250-00-B-00-R